

# ZERO-TURN MOWER

*OPERATOR'S MANUAL*

*3100 SERIES*

*MODELS: DUEZT2342-T3100*

*DUEZT2348-T3100*

*DUEZT2352-T3100*



November 27, 2025

## **General Information**

Thank you for choosing our zero-turn mower as your preferred lawn mowing machine.

This owner's manual contains information on safety instructions, assembly requirements, operation instructions and maintenance requirements to assist you in the correct use of the machine.

The manual also contains information on adjustment settings and troubleshooting procedures should you require them.

We advise that you read this manual in its entirety before operating the units performance features, assembly and maintenance requirements, to ensure that you prolong the life of your machine and promote quality and maximum efficiency.

As with all mechanical equipment, your machine will require cleaning and upkeep, remembering that it's important to regularly lubricate the machine as specified in the manual.

If the owners manual becomes lost or damaged in any way, please ensure that you seek a replacement copy immediately by contacting our sales department.

If additional information is required please contact our sales department.

The illustrations and data used in this manual were current at the time of printing.

However due to possible in-line production changes, your machine may vary slightly in detail.

The manufacturer reserves the right to make changes or add improvements to its products at any time without incurring any obligation to make such changes to previously manufactured products.

## **IMPORTANT**

This machine is a ride-on, rotary-blade lawnmower intended to be used by homeowners in residential applications. It is primarily designed for cutting grass on well-maintained lawns. It is not designed for cutting brush, mowing grass and other growth alongside highways, or for agricultural uses. But it also should be treated carefully as such, any misuse or mistreatment of the machine may result in death or serious injury to the operator.

Any mishandling or misuse of the machine may result in direct damage to the machine. It is the responsibility of the operator to practice safe handling of the machine at all times and adhere to the safety instructions outlined in the manual to avoid death or serious injury or damage to the machine.

## **CONTENTS**

1. SPECIFICATIONS
2. SAFETY SYMBOLS
3. SAFETY DECALS
4. SAFETY INFORMATION
5. ASSEMBLY INSTRUCTIONS
6. OPERATION
7. MAINTENANCE
8. ADJUSTMENTS
9. TROUBLESHOOTING

## ■ SPECIFICATIONS

Machine Model	DUEZT2342-T3100	DUEZT2348-T3100	DUEZT2352-T3100
Engine Type	Twin-cylinder four-stroke gasoline engine		
Engine Model	Loncin LC2P80F		
Engine Net Power	22.8 hp (17 kW) @ 3600 rpm		
Engine Displacement	764 cc		
Engine No-load max. Speed	3600 rpm		
Starter type	Electric		
Cutting Height	1 - 4 in (2.5 - 10.1 cm)		
Cutting Width	42 in (107 cm)	48 in (122 cm)	52 in (132 cm)
Blade Length	21.4 in (543 mm)	16.9 in (429 mm)	18 in (458 mm)
Number of Blades	2 pcs	3 pcs	3 pcs
Safety Electrical System	Safety interlocked		
Clutch	Ogura GT1.5	Ogura GT2.75	Ogura GT2.75
Transmission	Dual Hydro-Gear ZT-3100		
Steering	Dual levers independently control speed and direction of travel		
Forward speed	0 - 8.4 mph (13.5 km/h)		
Backward speed	0 - 5.6 mph (9 km/h)		
Fuel Tank Capacity	3.5 US gal (13 L)		
Drive Wheels	20 × 10 - 8		
Front Wheels	11 × 6 - 5		
Net Weight	705 lb (320 kg)	750 lb (340 kg)	772 lb (350 kg)
Over Size	1950 × 1400 × 1660 mm	1950 × 1565 × 1660 mm	1950 × 1634 × 1660 mm

## ■ SAFETY SYMBOLS



**This SAFETY ALERT SYMBOL** is used both in this manual and on the machine to alert you to important safety messages which must be followed to avoid accidents. This symbol means: **ATTENTION! BECOME ALERT!**

The safety alert symbol is to alert you to the unsafe action or situation and is accompanied by the word **DANGER, WARNING, or CAUTION.**



**DANGER** Failure to observe the safety instructions **WILL** result in death or serious injury.



**WARNING** Failure to observe the safety instructions **COULD** result in death or serious injury.



**CAUTION** Failure to observe the safety instructions **COULD** result in minor or moderate injury.

## ■ SAFETY DECALS

- All DANGER, WARNING, CAUTION and instructional messages on your machine should be carefully read and obeyed. Personal injury can result when these instructions are not followed. The information is for your safety and it is important! The safety decals below are on your machine. The position of decals refer to Fig. 1 and Fig. 2.
- Keep all safety decals legible. Remove all grease, dirt, and debris from safety decals and instructional labels.
- Safety decals must be replaced if they are

missing or illegible.

- When new components are installed, be sure that current safety decals are affixed to the replaced components.
- New safety decals may be obtained from your authorized equipment dealer or distributor .
- Familiarize yourself with the following safety decals and instruction labels. They are critical for the safe operation of your machine.

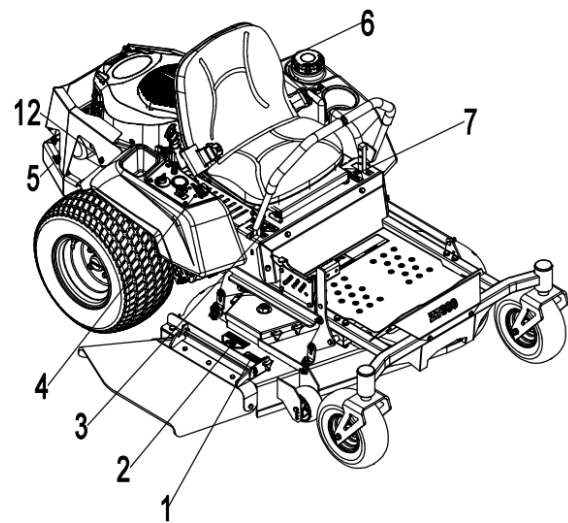

Fig. 1

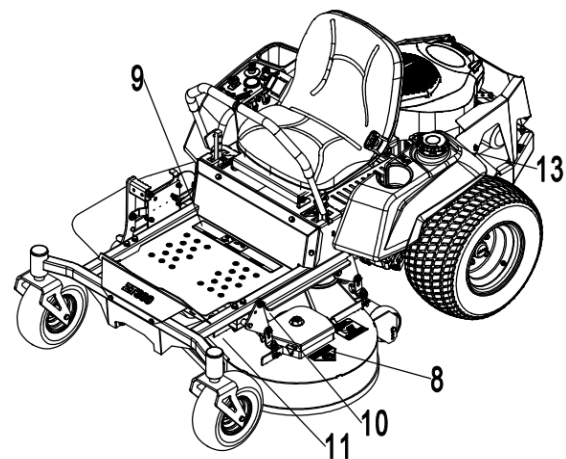

Fig. 2



DANGER!



Discharge Hazard - NEVER direct discharge toward people, pets or property. Thrown objects can cause injury or damage.



Read and understand the operator's manual before operating unit.



Amputation Hazard - NEVER stick hands or feet under deck or shielded areas.



Discharge Hazard - NEVER operate unit without discharge chute in operating position. Thrown objects can cause injury or damage.

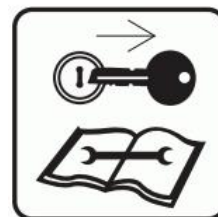

Shut off engine, remove key, and read manual before servicing or making adjustments to unit.

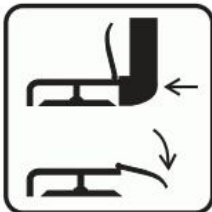

DO NOT operate mower unless all guards are in operating position or bagger is attached.



To avoid amputation hazard DO NOT put hands near rotating blades.



Keep children and others away from unit while unit is in operation.



To avoid amputation hazard DO NOT put hands near moving belts.



Keep feet and hands away from all rotating or moving parts.



Keep hands away from all rotating or moving parts.



DO NOT step or stand in this area.



Keep all guards and shields in place.



Avoid tipping hazard.



Look behind when operating the unit in reverse.



DO NOT operate on slopes over 15°.



ALWAYS keep hands and feet away from discharge chute.



Read owners manual before servicing or making adjustments to unit.



Clear the operating area of all objects before operating.



Set parking brake.



Wear suitable hearing protection.

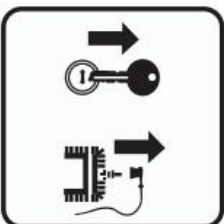

Remove key and disconnect spark plug before servicing or making adjustments to unit.



DO NOT touch parts which are hot from operation. ALWAYS allow parts to cool.



DO NOT operate the unit in the presence of bystanders.



DO NOT overfill. Fill fuel tank to below bottom of filler neck.



DO NOT carry passengers.



When pushing the rider by hand, place both bypass levers in the rearward position.

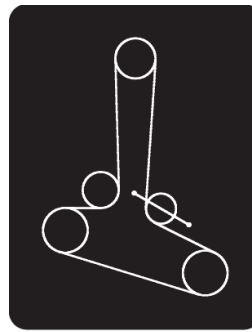

Deck Belt 42"

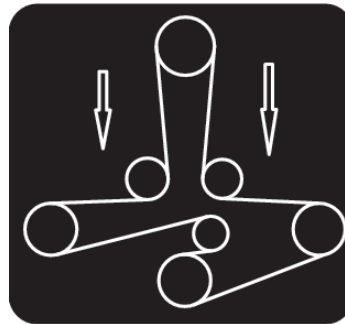

Deck Belt 48" & 52"



Controls engine speed.

42"

48" 52"

Cutting width.

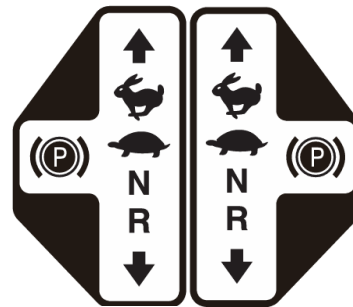

The steering levers control speed, motion and direction of the machine and the parking brake.



Cutting Height

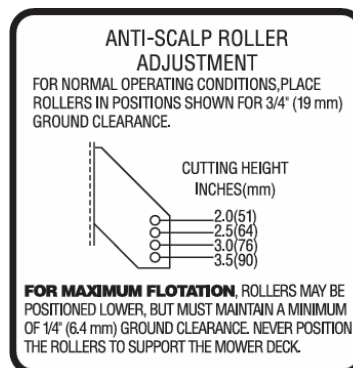

Anti-Scalp Wheels



Keep Rollover Protective Structure fully extended. Do not jump if machine tips. Use seat belt.

When structure must be down: DO NOT use seat belt. Drive with extra care.

## ■ SAFETY INFORMATION

### ⚠ CAUTION

The safety of this machine relies on it being operated within the conditions that explained in this manual. Please read the manual carefully before operating. Make sure the operator is thoroughly familiar with the safety rules.

#### Trainings

- Regard the machine as a piece of power equipment, so any person who operates the machine **MUST** be trained and capable of the safe operation of the equipment and controls.
- Know your controls and how to stop the

machine, engine and mower deck in an emergency.

- To avoid accident or injury, **DO NOT** allow anyone to operate this machine without reading the instruction.
- Never allow young children, or unqualified individuals to operate the equipment.
- Keep young children and pets away from the zone of operation to avoid accidents or hazards to other people or their property.

#### Preparation

- While mowing, always wear tight and belted clothing. Wear protected footwear. Never operate the machine in bare feet, open toed footwear.
- Walk around machine and visually inspect for damaged, loose, or missing components.
- **DO NOT** operate unless all components are properly installed, adjusted and in good working condition.
- Make sure all safety switches function properly.
- Make sure all safety shielding is in good condition and properly installed.
- Check brake action before you operate. Adjust or check brakes as required.
- Make sure all safety decals are installed and in good condition.
- Remove accumulated debris from machine to avoid fire hazard.
- Thoroughly inspect area to be cut and remove stones, branches, wires and accumulated debris that might be thrown causing personal injury or damage.
- Evaluate the terrain to determine what accessories and attachments are needed to properly and safely perform the job.
- Never permit any person, besides the operator, to ride or operate the mower at any time.
- Operate only in daylight or good artificial light.

## **Fuel Handling Safety**

- In certain conditions, gasoline is extremely flammable and highly explosive. A fire or explosion from gasoline can burn you and others and can damage property.
- Fill the fuel tank outdoors, in an open area, when the engine is cold. Wipe up any spill gasoline.
- DO NOT fill the fuel tank completely full. Add gasoline to the fuel tank until the level of the filler neck. This empty space in the tank allows gasoline to expand.
- Never smoke when handling gasoline, and keep away from open flames or where gasoline fumes may be ignited by a spark.
- Store gasoline in an approved container and keep it out of the reach of children.
- Never buy more than a 30-day supply of gasoline.
- Always place gasoline containers on the ground away from your vehicle before filling.
- Never use cellular phones or other portable electronic devices when handling fuel.

## **Operational Safety**

- Read “Operation” section of this manual before attempting to operate this machine.
- DO NOT operate without ROPS (Roll Over Protection System) deployed.
- Fenders serve as shields. DO NOT operate without them.
- DO NOT drive machine without mower deck installed. The proper stability of the machine depends on the weight of the mower deck.
- Keep bystanders away from equipment while it is in operation.
- Keep children and pets a safe distance. Never directly discharge towards a person.
- Start engine from operator’s seat after disengaging PTO and placing steering levers into the swing-out (neutral lock) position.

- Keep hands and feet away from underneath mower deck while engine is running. Keep clear of all moving parts on machine.
- Wear suitable hearing protection devices to protect engine noise.
- DO NOT operate in backward unless absolutely necessary and ensure the area behind you is clear and safe.
- The machine is equipped with a foldable Roll Over Protection System, always wear seatbelt when ROPS is deployed.
- When foldable ROPS must be down (i.e. loading or unloading on an enclosed trailer), DO NOT use seatbelt and drive carefully.
- DO NOT move steering levers from forward to backward or backward to forward position rapidly. The sudden direction change may cause loss of control.
- DO NOT operate on steep slopes greater than 15 degrees.
- DO NOT stop, start or change directions suddenly on slopes.
- Use extra care and maintain minimum ground speed when traveling or operating on a slope, over rough ground, or when operating close to ditches and fences.
- Keep alert for holes, rocks, roots and other hidden hazards in the terrain. Keep away from drop-offs and soft embankments.
- Stop machine and mower deck immediately while striking an obstruction or hard object. Turn engine off, inspect machine and mower deck. Repair any damage before resuming operation.
- Disengage PTO, stop engine, set the parking brake, remove key and wait for all movement to stop before dismounting, making adjustments, cleaning, or unclogging the machine.
- Never transport mower with blades running. Disengage PTO before crossing streets, sidewalks, driveways, etc.
- Watch for traffic when operating near or

crossing roadways.

- This machine is not equipped for highway use, especially when safety lighting and marking is required. It is NOT a recreational vehicle.
- This unit is equipped with a Towing Hook. Do not exceed the maximum load capacity when towing.
- Take all possible precautions when the machine is unattended: disengage PTO, lower mower deck, place steering levers in neutral, set parking brake, stop engine and remove key from ignition.
- Never carry passengers.
- DO NOT run engine in an enclosed area without adequate ventilation. Exhaust gases contain carbon monoxide, which is an odorless and deadly poison.

### **Maintenance Safety**

- Always undertake maintenance with the machine parked on a hard level surface; with the engine stopped and the PTO disengaged; with the park brake set; and with the key removed from the ignition.
- Always remove the grounded (-) clamp from the battery when performing maintenance on the engine, clutch, or any other electrical system.
- Always wear tight fitting clothing and safety equipment when performing maintenance . Keep work area clean and dry.
- Never work under the machine without jack stands or other equivalent safety blocks. DO NOT depend solely on mechanical or hydraulic jacks or lifts for support. Always use adequate wheel chocks on tires remaining on the ground.
- If it is necessary to run an engine in an enclosed area, remove the exhaust gases from the area with an exhaust pipe extension. If an exhaust pipe extension is not available, work near the open doors and windows.

- Waste products such as used oil, fuel, and batteries can harm the environment and people. Dispose of waste products properly.
- Never attempt to disconnect or alter any part of the safety interlock systems.
- DO NOT change engine governor settings.
- Keep engine free of grass, leaves, or excess grease to reduce fire hazard and minimize engine overheating.
- Keep machine and mower deck in good operating condition and all safety devices in proper place.
- Periodically tighten all bolts, nuts and screws. Check that all locking pins are properly installed and in good condition.
- Check brake operation frequently. Adjust and service as required.

### **Storing Safely**

- Never store the machine with gasoline in the tank inside a building where fumes may reach an open flame, spark or pilot light as on a furnace, water heater, clothes dryer, or other gas appliance. Allow engine to cool before storing .
- If engine is to be unused for 30 days or more, add a fuel stabilizer to the fuel system.
- If draining fuel tank, drain fuel into an approved container outdoors and away from open flame.
- Always provide adequate ventilation when running engine indoors. Exhaust gases contain carbon monoxide, which is an odorless and deadly poison.
- Remove all accumulated debris from mower deck and tractor.
- Sand areas where paint is chipped and repair to prevent rust. Lubricate all locations to prevent moisture damage during storage.

### **■ ASSEMBLY INSTRUCTIONS**

### Install Roll Over Protection System (ROPS)

Locate and align the ROPS with the machine frame(Refer to Fig. 3), torque all the nuts to  $50\pm 5\text{N.m}$ .

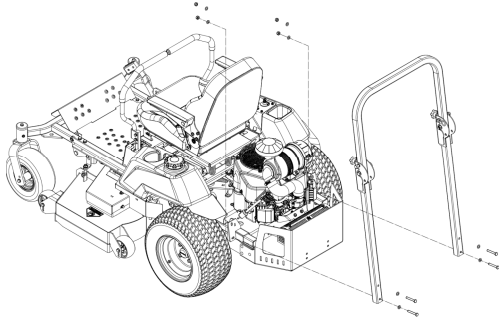

Fig. 3

### Install Seat

Locate and align the seat with the seat pan (Refer to Fig. 4), torque all the nuts until the seat is snug.

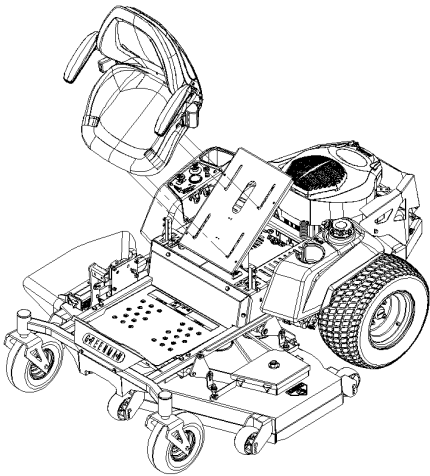

Fig. 4

### Install Steering Lever

- Loosen and remove the two bolts and spring washers which attach to the control arm shaft.
- Place the lever on the outside of the control arm shaft and secure with bolts and washers (Refer to Fig. 5),tighten until snug. Repeat on opposite side of unit.

available. Place the levers in the first and the second hole (from the top) to increase height of the levers, or in the second and the third hole(from the top) to decrease the height of the levers.

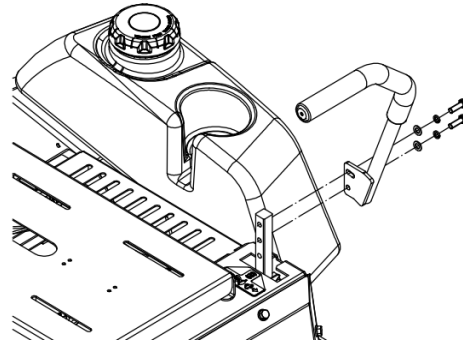

Fig. 5

### Install Discharge Chute

Locate the discharge to the mower deck(Refer to Fig. 6) and tighten knob until chute is snug.

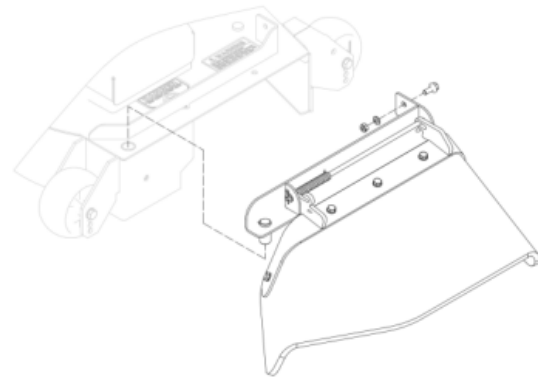

Fig. 6

### Service Battery



Charging the battery may produce explosive gasses that can explode causing serious injury.Keep sparks, flames, or cigarettes away from battery.

**NOTE:** There are two lever height options

- Simply lift up the seat to gain access to the battery.
- Check the voltage of the battery with a digital voltmeter.
- Connecting the negative battery cables.

### **IMPORTANT**

Make sure the negative & positive battery cables are correctly connected.

**Note:** If the positive cable is also disconnected, connect the positive (red) cable to the positive battery terminal first, then the negative (black) cable to the negative battery terminal. Slip insulator boot over the positive terminal.



### **CAUTION**

- Battery contains sulfuric acid, avoid contact and always shield eyes, face, skin and clothing from battery, cigarettes, flames or sparks could cause battery to explode
- DO NOT charge or use booster cables or adjust post connection without proper training.
- If battery acid comes in contact with skin or eyes then flush with water and call a physician immediately.
- Keep out of reach of children.

### **Service Engine**

Engine is shipped with oil, check oil level and if necessary fill to the appropriate level.

## ■ OPERATION

The safe operation of this machine is the responsibility of the operator. Any person who operates the machine **MUST** be instructed in and capable of the safe operation of the machine and all controls. Read all safety information.

### Controls And Switches

Know your controls and how to stop the machine, engine, and mower deck quickly in an emergency. **DO NOT** operate this machine until you are completely familiar with the controls and comfortable with your ability.

We recommend you practice in a flat open area **at half throttle** until you are comfortable with all the controls.

The two Steering Levers control speed, motion, and direction of the machine and are located on each side of the seat. The left lever controls flow of hydraulic oil from the left pump to the left drive wheel motor. The right lever controls flow of hydraulic oil from the right pump to the right drive wheel motor.

This allows left and right drive wheels to turn independently, which provides the “zero turn” ability. Each lever has two positions: The swung “out” neutral lock position, where the lever will not activate the pump; and the swung “in” operation position, where the lever will activate the pump.

The following controls are located on or beside the Operator’s Console which is located to the right side of the seat. Refer to Fig. 7.

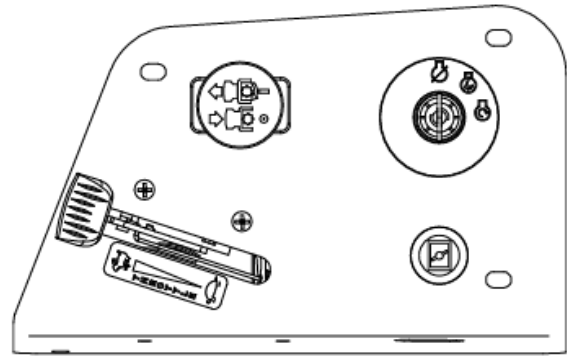

Fig. 7

- The Ignition Switch is the key switch located on the console. The ignition switch is used to start and stop the engine. The switch has three positions OFF, ON and START. Insert the key into the switch and rotate clockwise to the ON position.
- The Choke Control is the black knob on the console. Choke control is used to aid in starting a cold engine. Put the Choke control up or down can control the opening degree of the engine choke. For cold starts, pull the choke control up.
- The Throttle Control is the large black lever on the console. The throttle is used to control engine speed. Move the throttle lever forward to increase engine speed and backward to decrease engine speed.
- The PTO Switch is the red push/pull knob located on the console. Pull PTO knob “up” to engage the electric clutch that drives the belt connected to the mower deck that driving the cutting blades. Push the PTO knob “down” to disengage the electric clutch that stops the blades from turning within a few seconds.
- The Hour Meter is the number indicator located on the console. The meter is connected to the electric circuit and is provided to record the number of hours the engine runs. If the ignition switch is left on, without the engine running, the hour meter will continue to record. The meter is also connected to the battery and is provided to

show the remaining power of the battery.

- When the steering levers are centered in the T-slot, the drive system is in the neutral lock position. Place both steering levers in swing-out neutral lock position, the drive system is in the parking brake position. (Refer to Fig. 8)

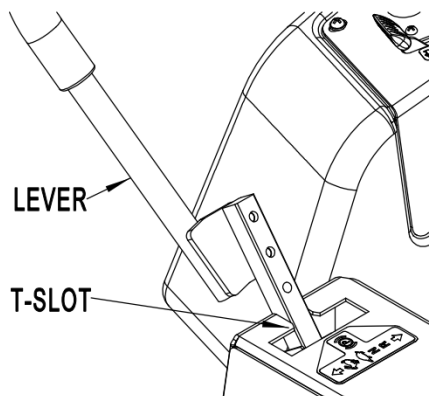

Fig. 8

Several Safety Switches are incorporated in this machine's design to prevent the engine from being started in certain conditions and to cease the running engine in certain conditions. These circuits should be checked before each operation to ensure they are working properly.

The Start Circuits will keep engine from starting unless:

- Both steering levers are swung out in their neutral locked position, and the PTO switch is down in its disengaged position.

The Kill Circuits will stop the running engine if:

- The operator comes off the seat any time during operation of the machine with PTO engaged or steering levers in operating position.

### **WARNING**

DO NOT operate this machine unless all safety systems are working properly as described

above.

### **Pre-Start Check List**

Maintain desirable operational standards and help ensure the safety of the operator by routinely checking the following on a daily basis.

Walk around the machine and visually check for loose or missing components. Make sure all components are mounted properly and are in good working condition.

- Make sure all fenders, guards and shields are safely and securely attached.
- Make sure the discharge shield or restriction plate is installed at the discharge opening on the mower deck.
- Make sure all safety decals are clearly readable.
- Check for oil and fuel leaks.

### **IMPORTANT**

When mowing in dusty conditions, dry grass or long grass, it may be necessary to frequently clean air intake screen to prevent engine overheating.

- Check air cleaner (refer to "Engine Manual"). When mowing in dusty conditions, dry grass or long grass, it may be necessary to frequently clean the air cleaner cartridge.
- Make sure the engine is free of dirt and debris.
- Check fuel level. Make sure fuel is enough .

### **DANGER**

DO NOT fill fuel tank while engine is running. Allow engine to cool two minutes before adding fuel. If fuel is spilled, DO NOT start engine and avoid creating a source of ignition until the fuel is wiped clean and evaporated.

- Check tire pressure . Improper pressure will adversely affect traction, steering and level cutting height.
- Check tires for damage or cracking.
- Check hydrostatic pump drive belt for damage or cracking.
- Check mower deck belt for damage or cracking.
- Check mower deck level.
- Check to ensure blades are sharp and secure;

the cutting edge should be positioned in the direction of blade rotation (clockwise as viewed from top of mower deck).

- Adjust cutting height if necessary.
- Check operation of park brake.
- Remove grass and debris from machine.
- Test safety interlock systems (Refer to Table 1). Perform these tests in a clear open area and keep bystanders away. If there is a malfunction during one of these procedures, DO NOT operate machine.

Table 1

Action	Left Steering Lever	Right Steering Lever	PTO Switch	Proper Result
Try starting engine	Out	Out	Off	Engines Cranks
Try starting engine	In	Out	Off	Engine will not crank
Try starting engine	Out	In	Off	Engine will not crank
Try starting engine	Out	Out	On	Engine will not crank
Raise off seat	Out	Out	Off	Engine does not stop
Raise off seat	In	Out	Off	Engine Stops
Raise off seat	Out	In	Off	Engine Stops
Raise off seat	Out	Out	On	Engine Stops

### Mounting And Dismounting The Mower

Always mount and dismount the mower from the left side, the PTO disengaged (down), the engine off, and the steering levers in their swung out (neutral lock) position.

Mount the mower by stepping from the ground to the left side of the deck with your right foot, then step over the frame to the footrest with your left foot. Always keep the top of the deck and footrest clean and dry.

Wait for all moving parts to stop before dismounting. Dismount the mower by standing up on the footrest, then turn to the left and step from the footrest, over the frame, to the left side of the deck with your right foot, and then step to

the ground with your left foot.

The left steering lever can be used to stabilize your movement; however, it is not strong enough to support all your weight. Never leave the mower unattended with the key in the ignition.

### Starting The Engine



Never start the engine in confined rooms. Exhaust gases contain carbon monoxide, an odorless and deadly poison. DO NOT allow children to approach the machine while the engine is running.

DO NOT operate the machine around open flames .

DO NOT operate the engine when an odor of fuel is present or other explosive conditions exist.

- Position yourself on the tractor seat.
- Place both steering levers in swing-out (neutral lock) position.
- Place electric clutch switch(PTO) in “OFF (down)” position.
- Set the throttle at 1/3 open.
- Insert the key into the ignition switch and turn to “ON”.
- Continue by turning the key to “START”. Choke as necessary to start. When engine starts release key immediately.
- Warm the engine up at medium speed for several minutes.

You will enhance the starter life by using short starting cycles of several seconds. Engaging starter motor more than 15 seconds can result in damage to starter.

### **Cold Weather Starting Tips**

- Use proper viscosity oil for temperature expected (see “Engine Manual”).
- Set throttle at half open.
- A warm battery has better starting capacity than a cold one.

### **Steering Lever Operation**

#### **WARNING**

**DO NOT move steering levers from forward to backward or backward to forward position rapidly. Sudden direction changes could cause loss of control or damage to the machine.**

#### **CAUTION**

**Help prevent personal injury. Learn use of the steering levers and practice at half throttle until you become proficient and comfortable with the operation of the machine.**

The steering levers control speed, motion and direction of the machine. The steering levers have two positions: (1) Neutral Lock, where the lever(s) are swung completely outward and cannot be moved front and back; (2) Operating, where the lever(s) are swung in and can be moved front and back.

### **Neutral Lock Position**

- Forward and backward movement of the motion control levers is prevented when levers are in the swung out (neutral lock) position. Machine should not move with the steering levers in the swung out (neutral lock) position.
- Steering levers must be in the swung out (neutral lock) position to start the engine.
- Steering levers must be in the swung out (neutral lock) position to safely enter and exit the operator seat.
- Operator can exit mower with the engine running when the steering levers are in the swung out (neutral lock) position, PTO switch is disengaged.

### **Operating Position**

- Machine speed, motion and direction can be controlled when the engine is running, and steering levers are in the swung in (operating) position.

### **Neutral**

- When the steering levers are swung in and centered front and back, they are in operating (neutral). In operating (neutral), the hydrostatic pumps do not deliver fluid to the wheel motors.

### **Forward and backward Motion**

- Pushing both levers forward at the same time will move the machine forward.
- Pulling both levers backwards at the same time will move the machine in backward. The further forward or backward the steering levers are moved, the faster the machine will move in that direction.

### **Turning**

- While moving forward, turn gently right by pushing the left lever further forward than the right.
- While moving forward, turn gently left by pushing the right lever further forward than the left.
- Make a sharp turn right by pushing the left lever forward and pulling the right lever backward at the same time.
- Make a sharp turn left by pushing the right lever forward and pulling the left lever backward at the same time.
- DO NOT turn the machine by leaving one lever in neutral and moving the other lever. This will cause damage to the turf under the tire that is not rotating.

### **Stopping**

To stop motion, move both steering levers back to neutral.

### **IMPORTANT**

If you become confused during operation in reverse, release both steering levers. They will automatically return to the centered neutral position and the machine will stop.

## STEERING LEVER OPERATION

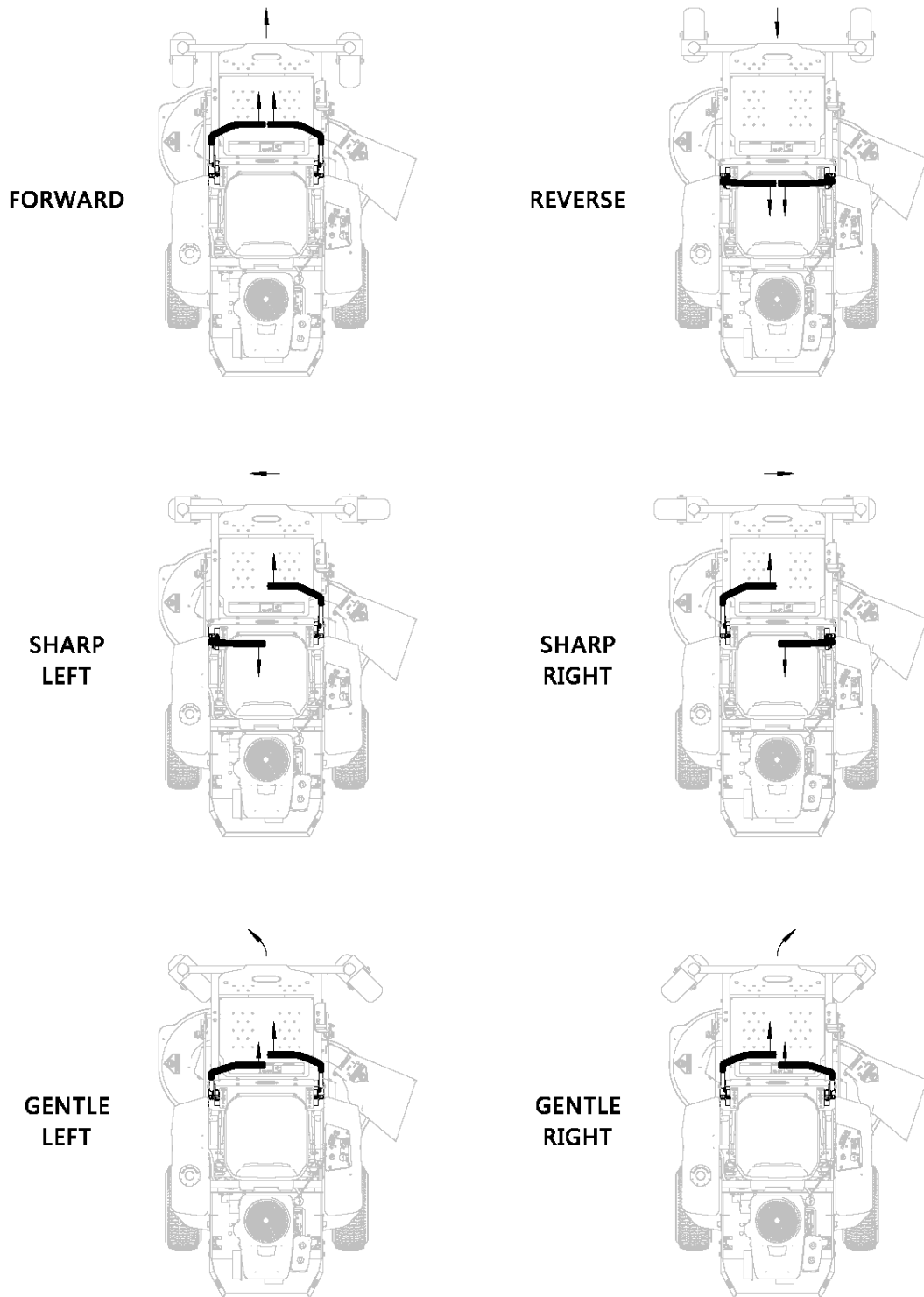

Fig. 9

## Mowing

### WARNING

Inspect area before mowing, picking up all rocks, twigs and other debris. Enter new areas carefully. Cut grass higher the first time to allow mower to clear unseen objects. Never assume an area is clear, always check!

Clear mowing area when operating mower.

Flying objects could injury bystanders.

### WARNING

Before starting to machine, position the machine in the area to be mowed with the mower deck set at the desired cutting height.

With the engine **at half throttle**, pull up on the PTO switch knob to start the blades turning.

Accelerate to **full throttle** to begin mowing.

### DANGER

To avoid serious injury or death from flying objects or contact with blades, NEVER operate mower without discharge shield or restriction plate installed. Keep hands and feet away from discharge opening.

Before mowing, inspect the area to determine the best mowing procedure. Consider height, type of grass and terrain type (rolling, level or rough).

Proper ground speed for mowing will depend on the height, type and density of grass to be cut.

Normally, ground speed will range from three to six miles per hour. Tall dense grass should be mowed at a low speed, while thin medium height grass can be cut at a faster ground speed.

Always operate engine at full governed RPM when mowing. This is necessary to maintain proper blade speed to produce a clean cut.

Follow local recommendations for the suitable cutting height in your area. Avoid mowing grass too short to increase mowing intervals. This may stress the grass during hot weather and

encourage weed growth during the growing season.

Mow with uncut grass to the left. This will distribute the clippings over the cut area.

Discharging clippings over the uncut area will cause a grass buildup and may prevent uniform cutting.

Remember that **sharp blades** produce cleaner cuts and use less power.

Extremely tall grass should be mowed twice.

Cut grass higher first, then cut the second time at desired height and 90° to the first pass.

## Uneven Terrain

- Be careful when operating mower on uneven ground.
- DO NOT operate on steep slopes. Operation on a steep slope could cause loss of control, machine to overturn and personal injury or death.
- DO NOT operate on steep slopes. This machine was not specifically designed to operate on steep slopes.
- The operator is responsible for safe operation on slopes. Only the operator can determine the stability of the mower on a given slope based on existing conditions like: machine speed and direction, slope variation, slipperiness, drop-offs, holes, obstacles, etc.
- Tires may lose traction on slopes even though the brakes are functioning properly.
- Avoid sudden starts and acceleration when traveling forward uphill as mower may tip backwards.
- DO NOT mow slopes when grass is wet because slippery conditions will reduce traction and braking which in turn affects steering.
- Use caution when making turns. Slow the mower down before making sharp turns. Unit can spin very rapidly by positioning one lever too much ahead or behind the other.

- Look around you to be sure the area is clear before turning or backing up.
- Avoid starting or stopping on a slope. If tires lose traction, disengage the blades and proceed slowly straight down the slope.
- Keep all movement on slopes slow and gradual. DO NOT make sudden changes in speed or direction.
- Use extra care with grass catchers or other attachments. These can change the stability of the machine. DO NOT use grass catcher on steep slopes.
- DO NOT operate without ROPS deployed.
- If machine is equipped with a fixed ROPS, always wear seatbelt.
- Wear seatbelt when mowing.
- Be certain that the seatbelt can be released quickly if the machine is driven or rolls into ponds or water.
- Check carefully for overhead clearances such as, branches, doorways, or electrical wires, before driving under any objects and DO NOT contact them.

### Stopping The Engine

1. Set the throttle at idle. Allow engine to idle for several minutes.
2. Move ignition switch to “OFF” position and remove key.

### CAUTION

Always remove key from ignition switch when leaving unit unattended or when not in use.

### Pushing The Rider By Hand

#### NOTICE

Do NOT tow zero-turn rider. Towing the units will cause hydraulic transmission damage. Do not use another vehicle to push or pull this unit.

#### IMPORTANT

There is one transaxle bypass lever on each side of unit. Ensure that both levers are fully

engaged or disengaged. Both transmission release levers must be in the same position.

Parking brake must be disengaged. Place steering levers in operating position.

To disengage the transaxles and move unit with the engine off, place both bypass levers in the rearward position.

To engage transaxles and operate unit normally, place both bypass levers in the forward position.



### Transporting Machine

#### WARNING

Always back machine onto trailer to avoid accidental upset.

Use a heavy-duty trailer to transport your machine. Trailer must have signs and lights required by law.

- Raise mower deck to the transport (highest) height position .
- Back machine onto trailer.
- Stop the engine. Place both steering levers in swing-out (neutral lock) position to engage the park brake and remove the key.
- Place the height adjustment pin in the bottom (1 inch) hole and lower the mower deck to the lowest position.

- Securely fasten machine to trailer with heavy-duty straps, chains or cables. Both front and rear straps must be directed down and outward from machine.

### Loading Machine

#### WARNING

Loading a machine onto a trailer or truck increases the possibility of backward-tip-over and could cause serious injury or death.

- Use extreme caution when operating a machine on a ramp. Move slowly.
- Avoid sudden acceleration and deceleration when operating a machine on a ramp.
- Back machine up ramp and drive forward down ramp.
- Use only a single, full width ramp; DO NOT use individual ramps for each side of the machine.
- If individual ramps must be used, BACK machine up ramp and drive forward down ramp.
- DO NOT exceed a 15 degree angle between ramp and ground or between ramp and trailer or truck.

### MAINTENANCE

#### CAUTION

**Always perform maintenance with the machine parked on a hard level surface; with the engine stopped and the PTO disengaged; with the park brake set; and with the key removed from the ignition.**

#### CAUTION

**Always remove the grounded (-) clamp from**

**the battery when performing maintenance on the engine, clutch, or any other electrical system. To access battery, simply lift up the seat.**

#### CAUTION

**Always wear safety glasses and ear protection when performing any maintenance function that could cause injury to eyes or ears.**

### Crankcase Oil And Air Filter

Refer to the “Engine Manual” for the timetable for changing or service.

### Check Engine Oil Level

Service Interval: Before each use or daily

- Stop engine and wait for all moving parts to stop. Make sure unit is on a level surface.
- Check when engine cold.
- Clean area around dipstick. Remove dipstick and wipe oil off. Reinsert the dipstick according to the engine manufacturer’s recommendations. Remove the dipstick and read the oil level.
- If the oil level is low, wipe off the area around the oil fill cap, remove cap and fill to the “FULL” mark on the dipstick. DO NOT overfill.

### Important

**DO NOT operate the engine with the oil level below the “ADD” mark on the dipstick, or over the “FULL” mark.**

### Lubrication

DO NOT let excess grease collect on or around parts, particularly when operating in sandy areas. See accompanying illustrations(Fig. 10 and Fig. 11) for the lubrication frequency points.

In addition to these lubrication points, lightly oil all linkage pivot points.

Be sure to clean fitting thoroughly before using grease gun.

Mower Blade spindles (A) and (B) Every 40-50 Hours of Usage

Front Wheel Bearing (A) and (B) Every 25 Hours/Monthly of Usage

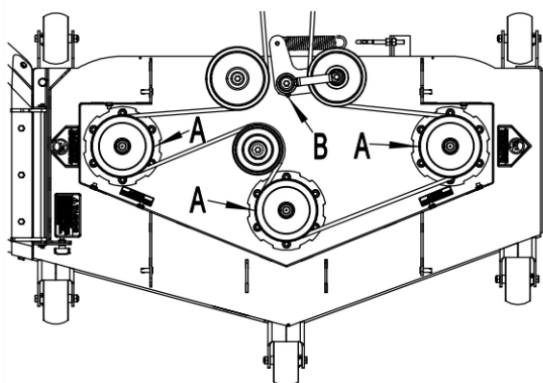

Fig. 10

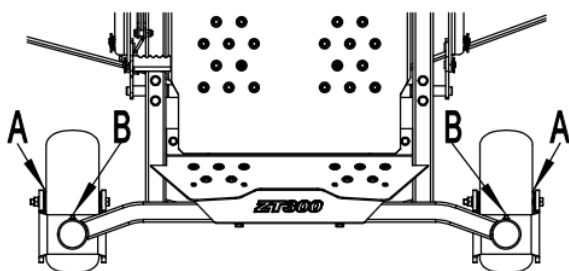

Fig. 11

## Hydraulic System ZT-3100

### Checking Drive System Fluid Level

The oil reservoir on the machine is located behind the seat. Notice the “full cold” line at the bottom of the tank. Do not overflow it.

### Transmission Oil Filter Change

This unit is equipped with two Integrated transmissions.

Removing the oil filter from the transaxle will drain the oil. Have a suitable container ready to catch any

spilled oil. **The manufacturer recommends that this be a dealer-only service item.**

### Fluid Type

The fluids used in Hydro-Gear products have been carefully selected, and only equivalent, or better products should be substituted.

Typically, an engine oil with a minimum rating of 9.0 cSt (55 SUS) at 230° F (110° C) and an API classification of SJ is recommended. A 15W45 engine oil has been selected for use by the factory and is recommended for normal operating procedures.

### Change Interval

This transaxle is designed with an external filter for ease of maintenance. To ensure constant fluid quality levels and longer life, an initial oil and filter change at **75-100 hours**, then **every 400 hours** thereafter is recommended.

### Purging the Air from the Hydraulic System

Due to the effects air has on efficiency in hydrostatic drive applications, it is critical that it is purged from the system.

Air creates inefficiency because its compression and expansion rate is higher than that of the oil approved for use in hydrostatic drive systems.

These purge procedures should be implemented any time a hydrostatic system has been opened to facilitate maintenance or the oil has been changed.

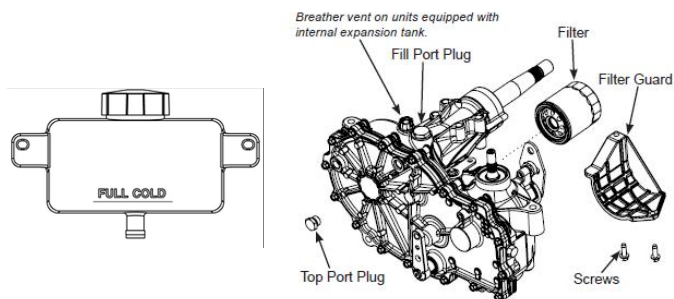

Figure 6, Unit With Internal Expansion Tank

### Tire Air Pressure

Drive Tires 20x10-8 15psi

Front Tires 11x6-5 20psi

## CAUTION

DO NOT use high-pressure water or steam to clean the engine or drive compartment. Water and cleaning detergent may damage electrical components and terminals, possibly leading to component and safety circuit failure.

Use a vacuum cleaner or air blower to remove foreign material from the engine and drive compartment.

### Battery Maintenance

Battery is located under the seat. Simply lift up the seat to access battery.

Follow the procedure below for battery maintenance.

- Clean battery.
- Inspect cables for loose connection.
- Clean terminals.
- Inspect battery tray and hold-down.
- Inspect battery case for cracks or leaks.

## WARNING

Batteries contain sulfuric acid. Avoid contact with skin, eyes and clothing. Batteries produce a highly explosive hydrogen gas while being charged. Always keep cigarettes, sparks, open flame and other sources of ignition away from battery. Always shield eyes and face from battery. In the event of accident, flush with water and call a physician immediately. Keep batteries and acid out of the reach of children.

### Deck Cleaning

#### IMPORTANT

After each use, remove grass buildup from under the mower deck. Excessive grass buildup will interfere with the operation and performance of the mower deck. Excessive grass buildup may also cause component failure.

- Park machine on hard level surface, stop engine and place both steering levers in swing-out (neutral lock) position to engage the park brake. Remove key from the ignition switch.
- Position the mower deck in the transport (all the way up) setting and the height adjustment pin in the 4 inch cutting height hole.
- Lift the front of the machine, using the front cross member of the deck carrier frame, and support the machine using jack stands or other equivalent safety blocks.
- DO NOT rely solely on mechanical or hydraulic jacks or lifts for support. Always use adequate wheel chocks on tires remaining on the ground.
- Use a long flat bar steel to clean under the deck, to avoid positioning yourself under the machine.
- Clean out all grass and debris build-up from the underside of the deck, around blade spindles and the deck discharge chute.

### Blade Inspection

#### WARNING

DO NOT handle mower blades with bare hands. Use heavy leather gloves or wrap blade with protective material and block securely when removing blades. Careless or improper handling may result in serious injury.

Inspect blades before each use to determine that they are mounted securely and are in good condition. Replace any blade that is bent, excessively nicked, worn, or has any other damage. Small nicks can be ground out when sharpening.

### Blade Removal

Remove bolt (A), which has right-hand thread

(Refer to Fig. 12), Remove lock elastic washer (B), blade.

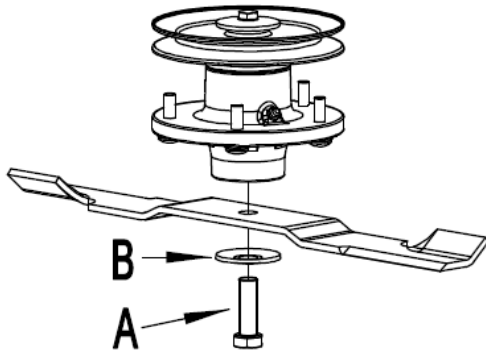

Fig. 12

### Blade Sharpening

#### ⚠ CAUTION

Always wear gloves when handling the mower blades. Always wear safety eye protection when grinding

- Sharpen the mower blades with grinder, hand file, or electric blade sharpener.
- Sharpen the mower blade by removing an equal amount of material from each end of the mower blade.
- Keep the original bevel (A, Fig. 13) when grinding. DO NOT change the mower blade bevel.
- The mower blade should have a maximum 1/64" (0.40mm) cutting edge (B, Fig. 13) or less.
- Balance the mower blades before installing.

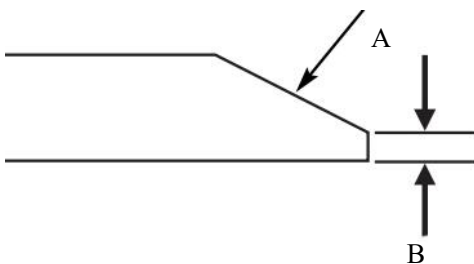

Fig. 13

### Balancing the Mower Blades

#### ⚠ CAUTION

An unbalanced mower blade can create excessive vibration and damage the unit or cause mower blade failure.

- Clean the mower blade to remove any dried grass or other debris.
- Refer to Fig. 14. Put the mower blade on a nail (A) in a vise and turn the mower blade to the horizontal position.
- Check the balance of the mower blade. If either end of the mower blade moves downward, sharpen the heavy end until the mower blade is balanced.
- Repeat the process until the mower blade remains in the horizontal position.

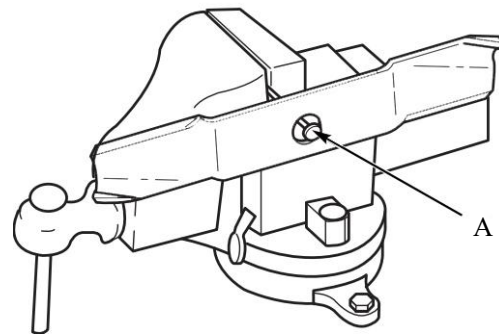

Fig.14

### Blade Installation

#### ⚠ WARNING

They are made of special steel alloys 40MnB and subjected to rigid heat-treat and inspection requirements. Substitute blades may not meet these rigid specifications and may be dangerous.

- Re-install each mower blade with the lift of blade pointing up towards the mower deck as shown in Fig. 13. Secure with the mower

blade mounting bolt and elastic washer (Fig. 12) and torque to 156-163N.m.

- Use a block of wood to prevent the mower blade from turning. (Refer to Fig. 15)

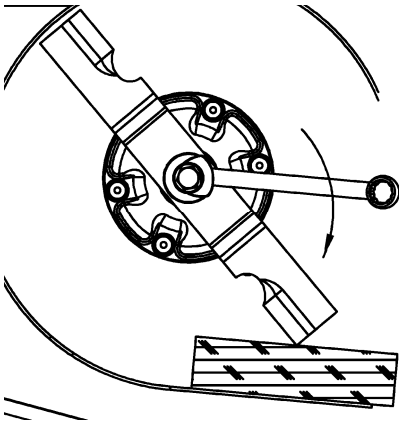

Fig. 15

## ■ ADJUSTMENTS

### IMPORTANT

Disengage PTO, shut off engine, wait for all moving parts to stop, and remove key before servicing, cleaning or making adjustments to the unit.

### Cutting Height Adjustment

(Refer to Fig. 16)

To set the deck cutting height:

- Push on the deck lift pedal to release pressure from the cutting height pin.
- Place the pin in the desired cutting height hole.
- Release the deck lift pedal.

Note: When changing the cutting height positions, always come to a complete stop and disengage the PTO.

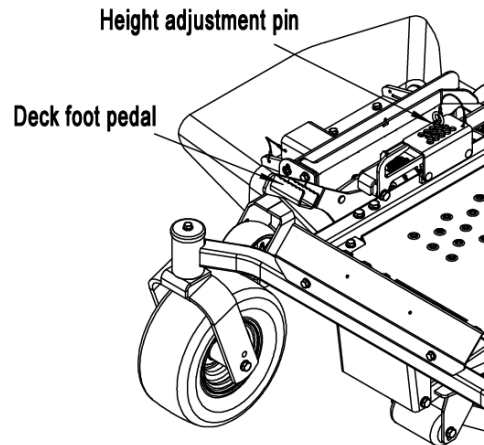

Fig. 16

### Deck Leveling Adjustment

#### Adjustment (SIDE TO SIDE)

- Position mower on a flat surface.
- Stop engine, wait for all moving parts to stop, and remove key.
- Check air pressure on all four tires and adjust to the correct pressure if necessary.
- Mower deck can be leveled at any cut height position. If blade heights do not match cut height setting, do not adjust at this time. Mower deck must be leveled side to side and front to rear before cut height setting is adjusted.
- Position left blade in the side to side position and measure from the outside blade tip to the level surface (Refer to Fig. 17).
- Position right blade in the side to side position and measure from the outside blade tip to the level surface.
- If the difference between both measurements is greater than 3mm, adjustment is necessary.
- Locate the level adjust nut (A) and nut (B) on the front right mower deck hanger (Refer to Fig. 18).
- Slightly loosen the nut (B) on the mower deck hanger.
- Adjust the mower deck up or down as required to match the right front by turning

the level adjust nut(A) clockwise to raise and counter-clockwise to lower.

- Adjust the level adjust nut (A) until blades on both sides are the same height above the level surface.
- With blades leveled side to side, tighten the nut (B) securely.

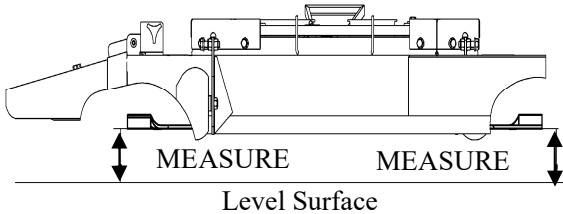

Fig. 17

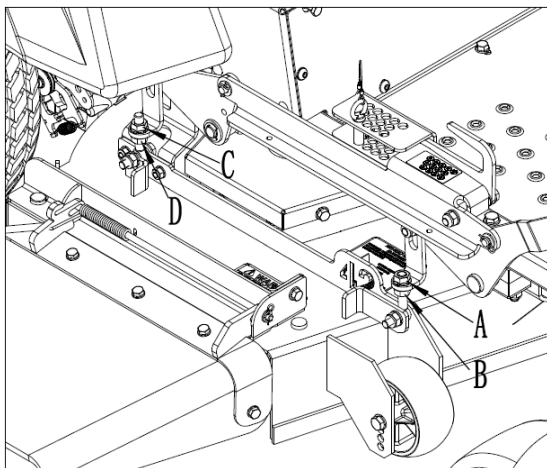

Fig. 18

### Deck Leveling Adjustment

#### Adjustment (FRONT TO REAR)

NOTE: Adjust side to side mower level before adjusting front to rear level (see previous section). The object is to have the mower blades cutting slightly lower in the front.

- Position left blade in the front to rear position. Measure from the left front blade tip to the level surface. With the blade in the same position, measure from the left rear blade tip to the level surface.

- The distance measured at the rear blade tip should be **3-5mm** higher than at the front blade tip.
- If the front to rear adjustment is not within the given tolerance, then either adjustment is necessary or the left blade may be bent.
- If the blade is straight and adjustment is necessary, simultaneously adjust nuts A and B on both sides of DECK.
- When the front to rear adjustment is within the given tolerance, simultaneously securely tighten the jam nut (B) on the deck lift rod assembly.

### Deck Belt Adjustment

The belt tension is set at the factory, but may need adjustment after **the first hour of initial use**. Periodically belt should be checked for proper tension, following the procedure below(Refer to Fig. 19).

- Position the mower deck in the lowest (1inch) cut height setting. Remove the Tread Footrest.
- Loosen the lock nut (A) and adjust the nut (C) to change belt tension.
- Increase belt tension by turning the nut (C) clockwise and decrease belt tension by turning the nut counterclockwise(Refer to Fig. 19).
- The idler spring (B) body length should measure approximately 145mm for proper belt tension.
- Tighten the lock nut (A) when the proper belt tension is achieved.

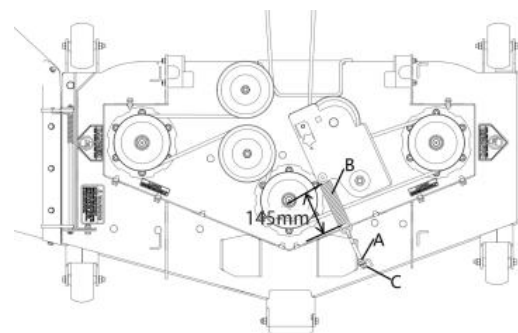

Fig. 19

## Pump Drive Belt Adjustment

The way is similar to the above of Deck Belt Adjustment ,The idler spring (B) body length should measure approximately 11cm for proper belt tension(Refer to Fig. 20).

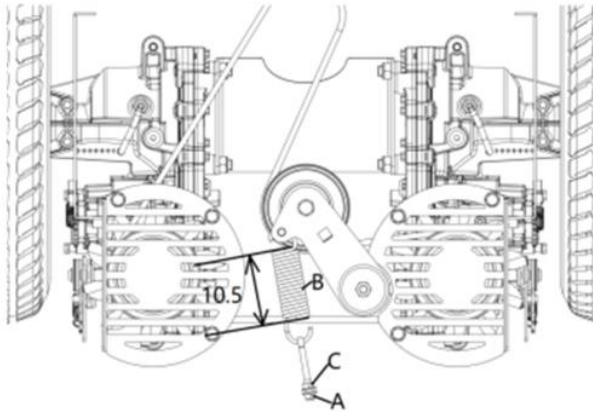

Fig. 20

## Neutral Adjustment

If drive wheels travel forward or backward when the steering lever is in the swung in **(operating neutral)** position, adjustment is required.

- Lift and support the rear of machine using jack stands or other equivalent safety blocks. DO NOT rely solely on mechanical or hydraulic jacks or lifts for support. Make sure two drive wheels keep away from the ground.
- Start the engine and put the steering levers in the swung in **(operating neutral)** position, then observe which drive wheel is rotating. That side will need to be adjusted.
- If the right wheel need to be adjusted, locate the position A(Refer to Fig. 21) .
- If the right wheel rotates clockwise, slightly loosen the nuts(B and C), then turn the neutral buckle (A of Fig. 22) counterclockwise(from the direction of arrow) until the wheel does not rotate. At last, tighten the nuts(B and C) securely.
- If the left wheel needs to be adjusted, use the same way to adjust the left wheel.

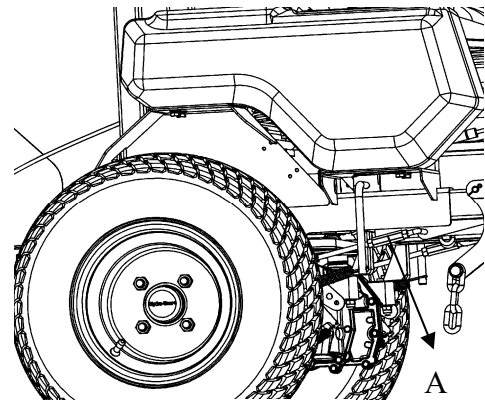

Fig. 21

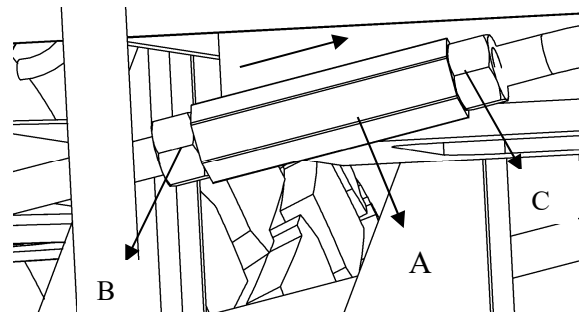

Fig. 22

## Seat Adjustment.

Pull up the handle on the right side of the seat, adjust the seat to the appropriate position, and release the handle. (Refer to Fig. 23)



Fig. 23

## Parking Brake Adjustment

- Disengage the PTO, stop the engine, block the front wheels, remove the ignition key.
- Locate the brake spring (A, Fig. 24).
- Place both steering levers in swing-out (neutral position). Gears in the brake arm(B) meshed into the gears of the brake disk.
- Measure the length of the spring with the parking brake engaged. If the spring is not within this range, release the parking brake and turn the adjustment nuts (B and C, Fig. 25) to compress or release the spring.
- Inspect and make sure the brake is adjusted correctly.

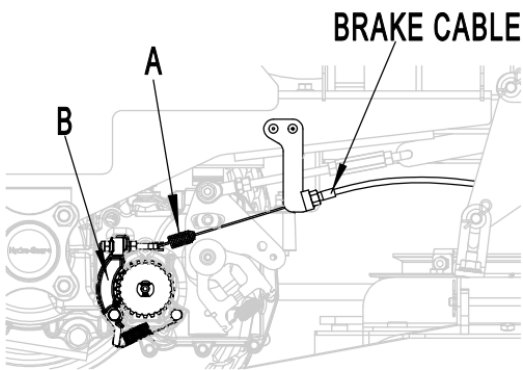

Fig. 24

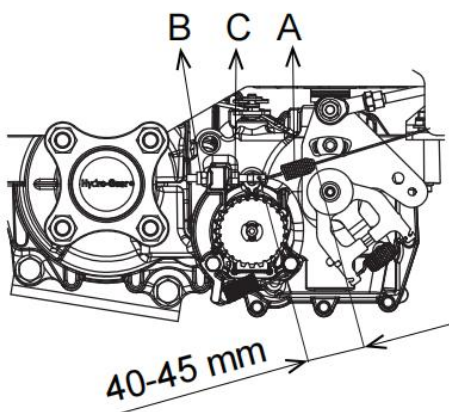

Fig. 25

## ■ TROUBLESHOOTING

### ⚠ WARNING

To avoid serious injury, perform maintenance on the mower only when the engine is stopped and the parking brake engaged.

Always remove the ignition key, disconnect the spark plug wire and fasten it away from the plug before beginning the maintenance, to prevent accidental starting of the engine.

While normal care and regular maintenance will extend the life of your equipment, prolonged or constant use may eventually require a service to be performed to allow it to continue operating properly.

The troubleshooting guide below lists the most common problems, their causes and remedies. See the information on the following pages for instructions on how to perform most of these minor adjustments and service repairs yourself. If you prefer, all of these procedures can be performed for you by your local authorized dealer.

Problem	Possible Cause	Corrective Action
Starter does not crank	<ol style="list-style-type: none"> <li>1. PTO is engaged.</li> <li>2. Drive levers are not in neutral lock position.</li> <li>3. Battery does not have a full charge.</li> <li>4. Electrical connections are corroded, loose or faulty.</li> <li>5. Fuse is blown.</li> <li>6. Relay or switch is defective.</li> <li>7. Relay or switch is defective.</li> </ol>	<ol style="list-style-type: none"> <li>1. Disengage the PTO.</li> <li>2. Ensure the drive levers are in the neutral lock position.</li> <li>3. Charge the battery.</li> <li>4. Check the electrical connections for good contact. Clean connector terminals</li> <li>5. thoroughly with electrical contact cleaner, apply dielectric grease and reconnect.</li> <li>6. Replace the blown fuse.</li> <li>7. Contact an Authorized Service Dealer.</li> </ol>
Engine will not start, starts hard, or fails to keep running	<ol style="list-style-type: none"> <li>1. Fuel tank is empty.</li> <li>2. Oil level in the crankcase is low.</li> <li>3. The throttle and choke are not in the correct position.</li> <li>4. Dirt in fuel filter.</li> <li>5. Dirt, water, or stale fuel is in the fuel system.</li> <li>6. Air cleaner is dirty.</li> <li>7. Seat switch is not functioning properly.</li> <li>8. Electrical connections are corroded, loose or faulty.</li> <li>9. Relay or switch is defective.</li> <li>10. Faulty spark plug.</li> <li>11. Spark plug wire is not connected.</li> </ol>	<ol style="list-style-type: none"> <li>1. Fill the fuel tank.</li> <li>2. Add oil to the crankcase.</li> <li>3. Be sure the throttle control is midway between the "SLOW" and "FAST" positions. For cold starts, pull the choke control up.</li> <li>4. Replace the fuel filter.</li> <li>5. Contact an Authorized Service Dealer.</li> <li>6. Clean or replace the air cleaner element.</li> <li>7. Check the seat switch . Replace seat switch if needed.</li> <li>8. Check the electrical connections for good contact. Clean connector terminals thoroughly with electrical contact cleaner, apply dielectric grease and reconnect.</li> <li>9. Contact an Authorized Service Dealer.</li> <li>10. Clean, adjust or replace spark plug.</li> <li>11. Check the spark plug wire connection.</li> </ol>
Engine loses power	<ol style="list-style-type: none"> <li>1. Engine load is excessive</li> <li>2. Air cleaner is dirty.</li> <li>3. Oil level in the crankcase is low.</li> <li>4. Cooling fins and air passages for the engine are plugged.</li> <li>5. Dirt in fuel filter.</li> <li>6. Dirt, water, or stale fuel is in the fuel system.</li> </ol>	<ol style="list-style-type: none"> <li>1. Reduce the ground speed.</li> <li>2. Clean or replace the air cleaner element.</li> <li>3. Add oil to the crankcase.</li> <li>4. Remove the obstructions from the cooling fins and air passages.</li> <li>5. Replace the fuel filter.</li> <li>6. Contact an Authorized Service Dealer.</li> </ol>

Problem	Possible Cause	Corrective Action
Machine does not drive	<ol style="list-style-type: none"> <li>1. Drive or pump belt is worn, loose or broken.</li> <li>2. Drive or pump belt is off a pulley.</li> <li>3. Broken or missing idler spring.</li> </ol>	<ol style="list-style-type: none"> <li>1. Change the belt.</li> <li>2. Change the belt.</li> <li>3. Replace the spring.</li> </ol>
Uneven cutting height.	<ol style="list-style-type: none"> <li>1. Blade(s) not sharp.</li> <li>2. Cutting blade(s) is/are bent.</li> <li>3. Mower deck is not level.</li> <li>4. Underside of mower is dirty.</li> <li>5. Tire pressure in drive tires not correct.</li> <li>6. Blade spindle bent.</li> <li>7. Tips of adjacent blades are at an uneven cutting height.</li> </ol>	<ol style="list-style-type: none"> <li>1. Sharpen the blade(s).</li> <li>2. Install new cutting blade(s).</li> <li>3. Level mower deck from side-to-side and front-to-rear.</li> <li>4. Clean the underside of the mower.</li> <li>5. Adjust tire pressure in the drive tires.</li> <li>6. Contact an Authorized Service Dealer.</li> <li>7. Replace blades, spindles and (or) check for damage to mower deck.</li> </ol>
Abnormal vibration	<ol style="list-style-type: none"> <li>1. Cutting blade(s) is/are bent or unbalanced.</li> <li>2. Blade mounting bolt is loose.</li> <li>3. Engine mounting bolts are loose.</li> <li>4. Loose engine pulley, idler pulley, or blade pulley.</li> <li>5. Engine pulley is damaged.</li> <li>6. Blade spindle is bent.</li> <li>7. Belt is damaged.</li> </ol>	<ol style="list-style-type: none"> <li>1. Install new cutting blade(s).</li> <li>2. Tighten the blade mounting bolt.</li> <li>3. Tighten the engine mounting bolts.</li> <li>4. Tighten the appropriate pulley.</li> <li>5. Contact an Authorized Service Dealer.</li> <li>6. Contact an Authorized Service Dealer.</li> <li>7. Install new belt.</li> </ol>
Blades DO NOT rotate.	<ol style="list-style-type: none"> <li>1. Drive belt is worn, loose or broken.</li> <li>2. Deck belt is worn, loose or broken.</li> <li>3. Deck belt is off pulley.</li> <li>4. Broken or missing idler spring.</li> <li>5. Drive belt not routed correctly.</li> </ol>	<ol style="list-style-type: none"> <li>1. Check the belt tension.</li> <li>2. Install new deck belt.</li> <li>3. Install belt on clutch and deck pulleys, idlers, and tensioning idler per routing decal on deck.</li> <li>4. replace the spring.</li> <li>5. Refer to belt routing decal on deck.</li> </ol>

Problem	Possible Cause	Corrective Action
Clutch willnot engage.	<ol style="list-style-type: none"> <li>1.Fuse is blown.</li> <li>2.Low voltage supply at the clutch.</li> <li>3.Damaged coil.</li> <li>4.Inadequate current supply.</li> <li>5.Rotor/armature air gap is too large.</li> </ol>	<ol style="list-style-type: none"> <li>1.Replace fuse. Check coil resistance,battery charge, charging system, and wiring connections and replace if necessary.</li> <li>2.Check coil resistance, battery charge,charging system, and wiring connections and replace if necessary.</li> <li>3.Replace clutch.</li> <li>4.Repair or replace clutch lead wire or electrical system. Clean connector contacts.</li> <li>5.Rreplace clutch.</li> </ol>