

# Stump Grinder

Operator's Manual

**MODEL NUMBER**

DUESGR1500-FLEX

**SERIAL NUMBER**

**PURCHASE DATE**

Both model number and serial number may be found on the main label. You should record both of them in a safe place for future use.

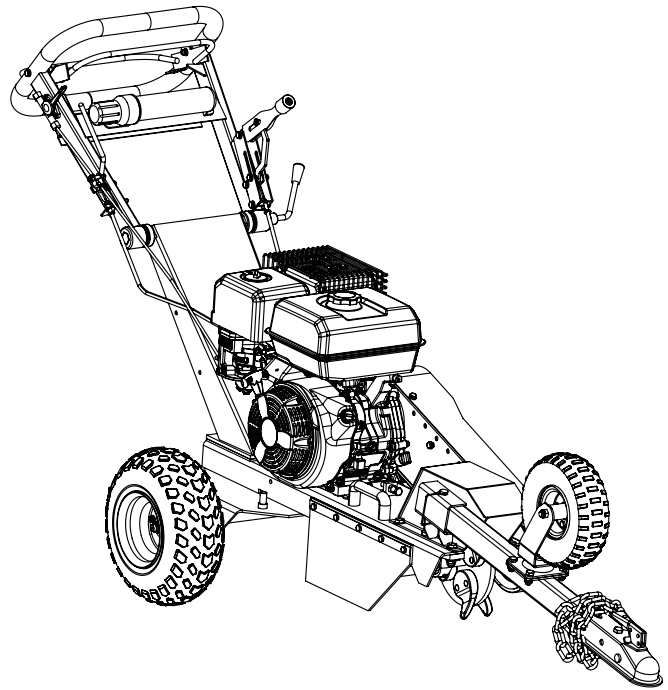

---

**FOR YOUR SAFETY**

**READ AND UNDERSTAND THE ENTIRE MANUAL BEFORE OPERATING MACHINE**

---

Your new Stump Grinder offers quality construction, and is easy and safe to operate. With proper use and care, it is designed to give you many years of dependable service.

Prepare to experience the durability to take on any job with the ease, portability, and convenience of your new Stump Grinder!

### **MAX performance,MAX Value,MAX Support that's Stump Grinder**

- ✓ Backed by decades of proven manufacturing expertise
- ✓ Enhanced design features come standard
- ✓ Engineered for the best user experience
- ✓ Quality metal parts are used instead of plastic
- ✓ A robust warranty supports all products
- ✓ Budget-friendly prices make it practical

---

## **TABLE OF CONTENTS**

---

Introduction	1	Operation	12
Symbols	3	Maintenance	16
Specifications	4	Important safety Information	18
Safety	5	Troubleshooting	22
Contents Supplied	8		
Assembly	9		
Know Your Machine	11		



*Carefully read through this entire operator's manual before using your new unit. Pay attention to all cautions and warnings.*

Your stump grinder is intended for outdoor-use only and can be used to remove many trees stumps and exposed root systems close to ground level. By moving the blade in sweeping movements laterally over the top and front of the stump, you can gradually grind it away. Make sure you completely read and understand this manual before using the grinder for the first time.

## WARNING

READ and UNDERSTAND THIS MANUAL COMPLETELY BEFORE USING THE GRINDER! Failure to properly operate, and maintain this grinder could result in serious injury or death to the operator or bystanders.

All machines have hazards associated with their operation. This stump grinder has certain special hazards, which you must aware of. As an operator or owner you have a duty to be aware of these hazards and know.

Preventive measures to take to avoid them. When reading this manual pay particular attention to avoiding these hazards.

- In particular, be aware of the following:
- Know location of buried electrical and other utility lines.
- Do not allow children or untrained adults to operate.
- Wear eye protection and other personal protection against flying rocks and debris.
- Check that cutter wheel teeth are secured, sharp and not missing.
- Do not operate if operator presence bar fails to stop engine upon release.
- Make sure no children or bystanders are within 75 feet (25m) of stump grinding operation.
- Protect cars, windows and other objects within 75 feet (25m) from flying debris.
- Be prepared for machine "kickback" when initially contacting the stump.
- Be aware of potential for carbon monoxide (CO) poisoning.
- Prevent fires/explosions from fueling.
- Do not attempt to perform adjustments, clean unit while engine is running.
- Avoid burns from engine or hot exhaust.
- Avoid using in wet or icy conditions where falls may occur.

Details about these hazards are found throughout the manual and are summarized at the end of the manual under "Important Safety Information"

## STOP

**ADD ENGINE OIL:** Your stump grinder comes fully assembled and requires only that you add engine oil to crankcase and fuel to tank.

**INSPECT COMPONENTS:** Closely inspect to make sure no components are missing or damaged. See the "Receiving Your Unit" section for instructions on whom to contact to report missing or damaged parts.



*Recycle unwanted materials instead of disposing of them as waste. All tools, hoses and packaging should be resorted, taken to the local recycling center and disposed of in an environmentally safe way.*

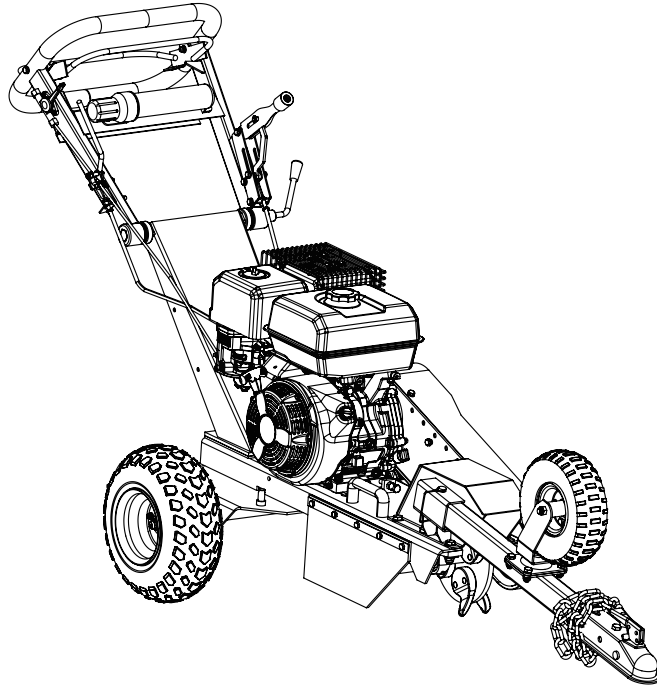

## SYMBOLS

The rating plate on your machine may show symbols. These represent important information about the product or instructions on its use.



Read these instructions for use carefully.



No smoking, No sparks, No flames.



Wear eye protection.



Keep your hand and feet away from moving parts.



Wear protective gloves.



Thrown Objects.



Wear safety footwear.



Be sure the engine's switch is off before transporting the machine or performing any maintenance.



Do not remove or tamper with the protection and safety devices.



Keep bystanders away.



Do not touch parts which are hot from operation. Serious burns may result.

**SPECIFICATIONS**

<b>Model Number</b>	
<b>Engine</b>	Ducar
<b>Displacement</b>	420cc
<b>Net Power</b>	15hp (9.0kw)
<b>Weight</b>	104KGS
<b>Operating RPM</b>	3600 RPM
<b>Length</b>	1730mm
<b>Width</b>	760mm
<b>Height</b>	1160mm
<b>Type of Fuel</b>	Gasoline
<b>Starting</b>	Recoil
<b>Oil Sensor</b>	Yes
<b>Wheel Tire</b>	145/70-6
<b>Cutter Wheel</b>	
<b>Diameter</b>	9.45" (240mm)
<b>Thickness</b>	4.72" (12mm)
<b>Bearing</b>	UCP205
<b>Cutter Wheel RPM</b>	2500 rpm/min
<b>Drive</b>	Direct Belt Drive Centrifugal Clutch
<b>Cutting Capacity</b>	
<b>Above Grade</b>	10" (254mm)
<b>Below Grade</b>	9" (230mm)
<b>Stump Diameter</b>	No Limit
<b>Teeth, Carbide Tips</b>	
<b>Steel Type</b>	42CrMo
<b>Steel Hardness</b>	HRC40-42
<b>Weight</b>	1.59 lbs (0.72kg)
<b>Length*Width*Tip Length</b>	4-1/4" (10.8cm)*2-13/16" (7.1cm)*1-1/2" (3.8cm)

---

# SAFETY

---

## GENERAL SAFETY RULES

### UNDERSTAND YOUR MACHINE

Read this manual and labels affixed to the machine to understand its limitations and potential hazards.

Be thoroughly familiar with the controls and their proper operation. Know how to stop the machine and disengage the controls quickly.

Make sure to read and understand all the instructions and safety precautions as outlined in the Engine Manufacturer's manual packed separately with your unit. Do not attempt to operate the machine until you fully understand how to properly operate and maintain the engine and how to avoid accidental injuries and/or property damage.

If the unit is to be used by someone other than original purchaser or loaned, rented, or sold, always provide this manual and any needed safety training before operation. The user can prevent and is responsible for accidents or injuries that may occur to themselves, other people, and property.

Do not force the machine. Use the correct machine for your application. The correct machine will do the job more efficiently and safer at the rate it was designed.

### PERSONAL SAFETY

Do not permit children to operate this machine at any time.

Keep children, pets, and other people not using the unit away from the work area. Be alert and shut off unit if anyone enters work area. Keep children under the watchful care of a responsible adult.

Do not operate the machine while under the influence of drugs, alcohol, or any medication that could affect your ability to use it properly.

Dress properly. Wear heavy long pants, boots, and gloves. Do not wear loose clothing, short pants, or jewelry of any kind. Secure long hair so it is above shoulder level. Keep your hair, clothing, and gloves away from moving parts. Loose clothes, jewelry, or long hair can be caught in moving parts.

Protect eyes, face, and head from objects that may be thrown from the unit. Always wear safety goggles or safety glasses with side shields when operating.

Wear appropriate hearing protection.

Always keep hands and feet away from all moving parts during operation. Moving parts can cut or crush body parts.

Always keep hands and feet away from all pinch points.

Do not touch parts that might be hot from operation. Allow parts to cool before attempting to maintain, adjust, or service.

Stay alert, watch what you are doing, and use common sense when operating the machine.

Do not overreach. Do not operate the machine while barefoot or when wearing sandals or similar lightweight footwear. Wear protective footwear that will protect your feet and improve your footing on slippery surfaces. Keep proper footing and balance at all times. This enables better control of the machine in unexpected situations.

### INSPECT YOUR MACHINE

Check your machine before starting it. Keep guards in place and in working order. Make sure all nuts, bolts, etc., are securely tightened.

Never operate the machine when it is in need of repair or is in poor mechanical condition. Replace damaged, missing, or failed parts before using it. Check for fuel leaks. Keep the machine in safe working condition.

Do not use the machine if the engine's switch does not turn it on or off. Any gasoline powered machine that can't be controlled with the engine switch is dangerous and must be replaced.

Regularly check to see that keys and adjusting wrenches are removed from the machine area before starting it. A wrench or a key that is left attached to a rotating part of the machine may result in personal injury.

Avoid accidental starting. Be sure the engine's switch is off before transporting the machine or performing any maintenance or service on the unit. Transporting or performing maintenance or service on a machine with its switch on invites accidents.

If the machine should start to vibrate abnormally, stop the engine (motor) and check immediately for the cause. Vibration is generally a warning sign of trouble.

**ENGINE SAFETY**

This machine is equipped with an internal combustion engine. Do not use on or near any unimproved, forest covered, or brush covered land unless the exhaust system is equipped with a spark arrester meeting applicable local, state, or federal laws.

In the state of California, a spark arrester is required by law. Other states have similar laws. A spark arrester, if used, must be maintained in effective working order by the operator.

Never start or run the engine inside a closed area. The exhaust fumes are dangerous, containing carbon monoxide, an odorless and deadly gas. Operate this unit only in a well-ventilated outdoor area.

Do not tamper with the engine to run it at excessive speeds. The maximum engine speed is preset by the manufacturer and is within safety limits. See engine manual.

Keep a Class B fire extinguisher on hand when operating this Wood chipper in dry areas as a precautionary measure.

**FUEL SAFETY**

Fuel is highly flammable, and its vapors can explode if ignited. Take precautions when using to reduce the chance of serious personal injury.

When refilling or draining the fuel tank, use an approved fuel storage container while in a clean, well-ventilated outdoor area. Do not smoke, or allow sparks, open flames, or other sources of ignition near the area while adding fuel or operating the unit. Never fill the fuel tank indoors.

Keep grounded conductive objects, such as tools, away from exposed, live electrical parts and connections to avoid sparking or arcing. These events could ignite fumes or vapors.

Always stop the engine and allow it to cool before filling the fuel tank. Never remove the cap of the fuel tank or add fuel while the engine is running or when the engine is hot. Do not operate the machine with known leaks in the fuel system.

Loosen the fuel tank cap slowly to relieve any pressure in the tank.

Never overfill the fuel tank. Fill the tank to no more than 1/2" below the bottom of the filler neck to provide space for expansion as the heat of the engine can cause fuel to expand.

Replace all fuel tank and container caps securely and wipe up spilled fuel. Never operate the unit without the fuel cap securely in place.

Avoid creating a source of ignition for spilled fuel. If fuel is spilled, do not attempt to start the engine but move the machine away from the area of spillage and avoid creating any source of ignition until fuel vapors have dissipated.

When fuel is spilled on yourself or your clothes, wash your skin and change clothes immediately.

Store fuel in containers specifically designed and approved for this purpose.

Store fuel in a cool, well-ventilated area, safely away from sparks, open flames, or other sources of ignition.

Never store fuel or a machine with fuel in the tank inside a building where fumes may reach a spark, open flame, or any other source of ignition, such as a water heater, furnace, or clothes dryer. Allow the engine to cool before storing in any enclosure.

**SPECIFIC SAFETY RULES**

Identify hazards and take preventive steps to avoid accidents and minimize risk. Possible hazards include, but are not limited to, moving parts, thrown objects, weight of the machine and components, and the operating environment.

**PRIOR TO STARTING**

Thoroughly inspect the area in which you are working, keeping it clean and free of debris to prevent tripping. Operate on a flat level ground.

Before starting your chipper shredder: make sure the feed hopper and cutting housing are empty and free of all debris, check the oil level, make sure all nuts and bolts are tight, and check the air pressure in the tires.

**OPERATION SAFETY**

Never place any part of your body where it would be in danger if movement should occur during assembly, installation, operation, maintenance, repair, or moving.

Keep all bystanders and pets at least 75 feet away. If you are approached, stop the unit immediately.

## ABOUT YOUR GRINDER

### Owner/Operator/Renter Training

Read and follow all instructions and safety precautions presented throughout this manual. A summary of important safety information can be found at the end of the manual. Keep this manual for reference and review. If the owner of this unit is different than the operator, give a copy of this manual to any operator to read.

### Rental Companies

All persons to whom you rent/loan this grinder must have access to this manual and read it. Check the tube on the side of the unit to make sure a manual is inside. Advise all persons who will operate the machine to read it. You should also provide personal instruction on how to safely operate the grinder and remain available to answer any questions a renter/borrower might have. If videos are available, have renter watch training video.

### Engine Instructions

For detailed engine operation and maintenance information, always refer to the engine Owner's Manual furnished with the grinder.

### Product Suitability

Before using, the user shall determine the suitability of this product for this intended use and assumes liability therein.

Your stump grinder can be used to remove many tree stumps and exposed root systems close to ground level. By moving the blade in sweeping movements laterally over the top and front of the stump, you can gradually grind it away. Make sure you completely read and understand this manual before using the grinder for the first time. If you have any question, contact your retail or rental dealer or manufacturer.



**WARNING:** *Never attempt to cut on a slope exceeding 15°*

Exercise caution when cutting stumps on an incline, as the machine may shift or slide unpredictably. Never attempt to cut with the machine uphill or downhill from you as it may slide toward you or you may fall toward the machine. Cut only on a slope from the side.

The supplier is constantly improving its products. The specifications outlined herein are subject to change without prior notice or obligation. The purchaser and/or user shall assume liability for any modification and/or alterations of this equipment from original design and manufacturer.

### Warranty Registration

Please fill out and submit the warranty registration card so that we have your contact information for any future product literature or replacement parts you may need.

Avoid contact with hot fuel, oil, exhaust fumes and hot surfaces. Do not touch the engine or muffler. These parts get extremely hot from operation. They remain hot for a short time after you turn off the unit. Allow the engine to cool before doing maintenance or making adjustments.

If the machine should start to make an unusual noise or vibration, immediately shut off the engine, disconnect the spark plug wire, and check for the cause. Unusual noise or vibration is generally a warning of trouble.

Use only attachments and accessories approved by the manufacturer. Failure to do so can result in personal injury.

Keep the engine and muffler free of grass, leaves, excessive grease or carbon build up to reduce the chance of a fire hazard.

Never douse or squirt the unit with water or any other liquid. Keep handles dry, clean and free from debris. Clean after each use.

Observe proper disposal laws and regulations for gas, oil, etc. to protect the environment.

When storing machine out of the reach of children and do not allow persons unfamiliar with the machine or these instructions to operate it. This machine can be dangerous when used by an untrained user.

### MAINTAINING YOUR MACHINE

Some parts of this machine are made of plastic or rubber and should be kept away from chemicals.

Never cover the machine while the muffler is still hot.

Do not alter or adjust any part of the chipper shredder or its engine that is sealed by the manufacturer or distributor. Only a qualified service technician may adjust parts that increase or decrease governed engine speed.

To maintain your machine, check for any misalignment or binding of any moving parts. Parts that are broken or worn down that may affect the machine's operation. If damage or worn parts are identified, they should be repaired before use. Many accidents are caused by poorly maintained equipment.



## CONTENTS SUPPLIED

Your Stump grinder comes partially assembled and contains the following:

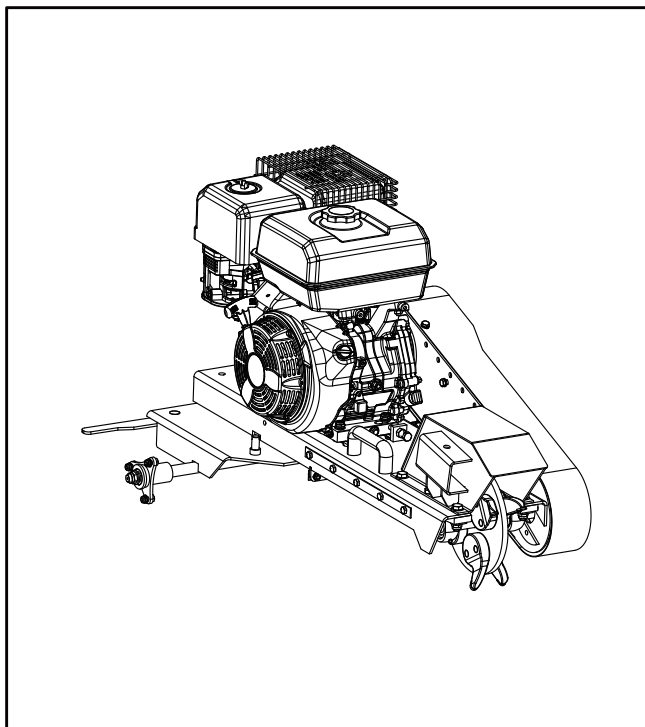

**1x Engine and Drum**

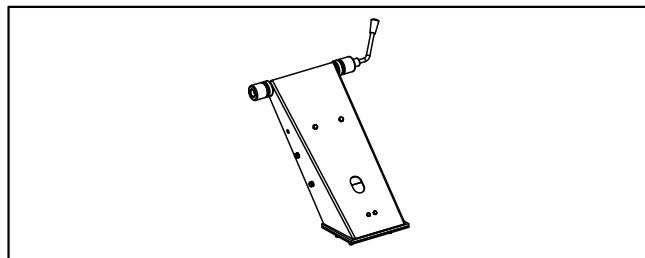

**1x Lower Push Frame**

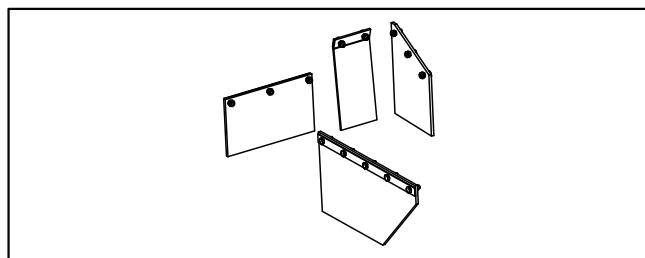

**1x Rubber Baffle**

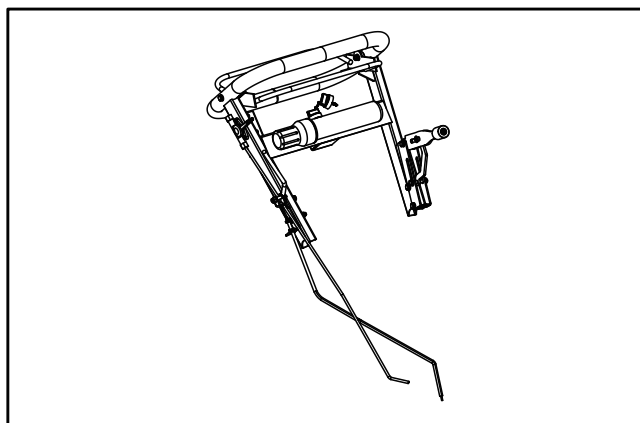

**1x Upper Push Frame**

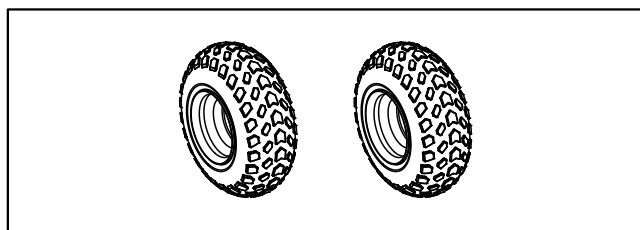

**1x Wheels**

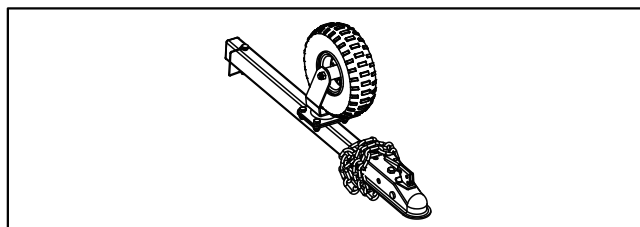

**1x Tower bar**

Verify all component and hardware quantities are correct prior to assembling the Stump grinder.

# ASSEMBLY

## Wheels

Fix the wheel on the axle with M14, M8X20 hexagonal bolts, M8 lock nuts and flat washers 8. (See Figure 1)

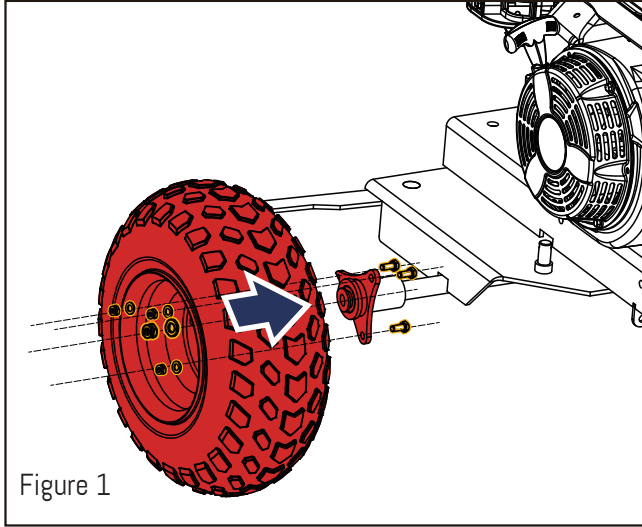

Figure 1

- 6X Hex lock nut M8 
- 6X Hex bolt M8 X 20mm 
- 6X Flat washer 8 
- 2X Hex lock nut M14 
- 2X Flat washer 14 

## Lower welding push rod

Attach the lower push rod to the body base with M12x55 hex bolt, flat washer 12 and M12 lock nut. (See Figure 2)

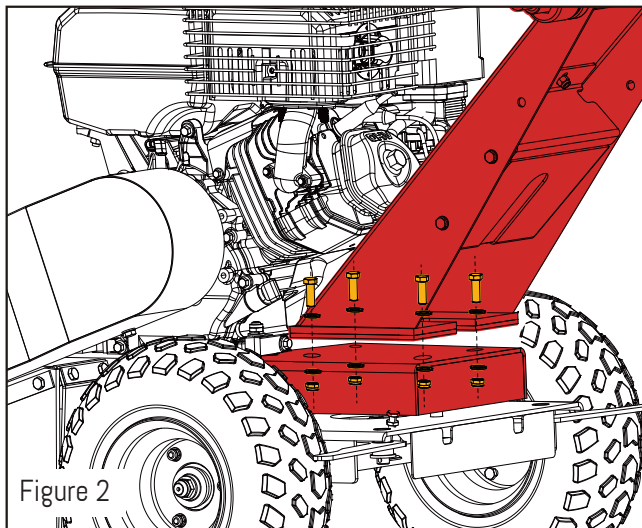





Figure 2

- 4X Hex lock nut M12 
- 4X Hex bolt M12 X 55mm 
- 8X Flat washer 12 

## Upper welding push rod

Use M16X360 hex bolts and M16 lock nuts to pass through the upper push rod and connect to the lower push rod.

Use M8 nut to fix the rotary pin cable to the left upper push rod, and connect the brake cable to the right upper push rod with M8x45 bolt and M8 nut.

Connect the throttle control to the upper push rod with M6X40 hex bolt and M6 lock nut. (See Figure 3)

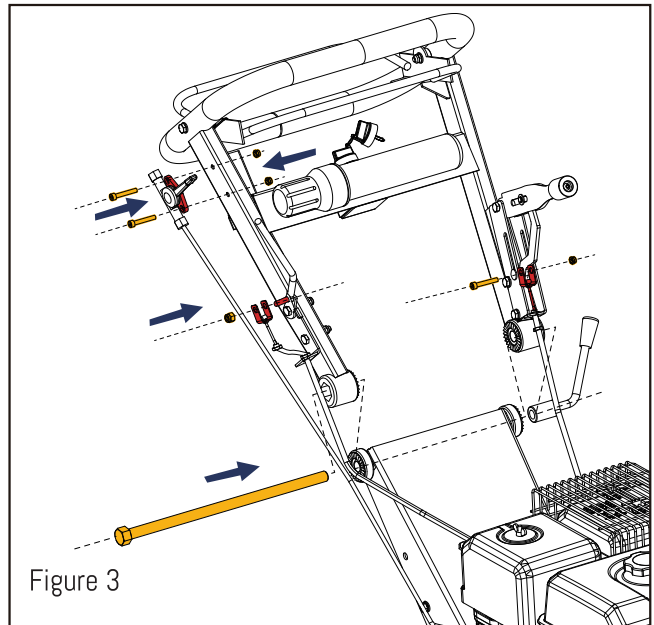
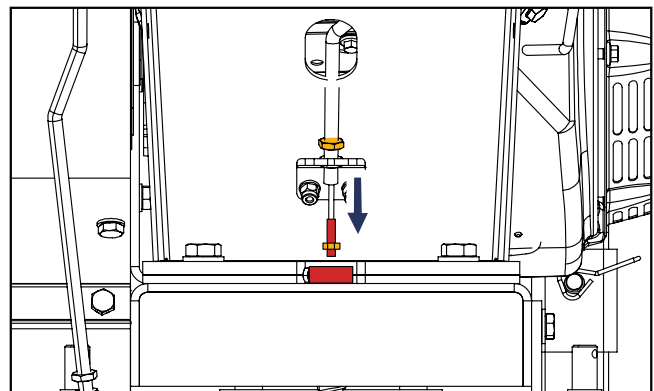

Figure 3

Tighten nut M10 and attach the other end of the rotating pin cable to the chassis with a M5.



2X	Hex lock nut M8	
1X	Hex bolt M8 X 45mm	
2X	Hex lock nut M6	
2X	Hex bolt M6 X 40mm	
1X	Hex bolt M16 X 360mm	

### Tow bar and Guiding wheel

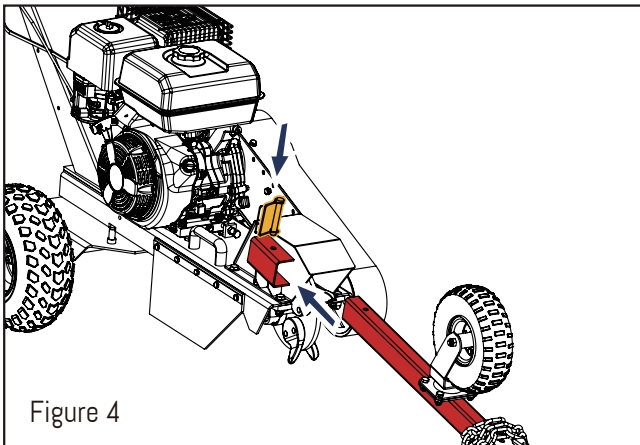

Use the square lock pin (12×80) to connect the towing bar and the guide wheel to the main body of the machine.( See Figure 4)

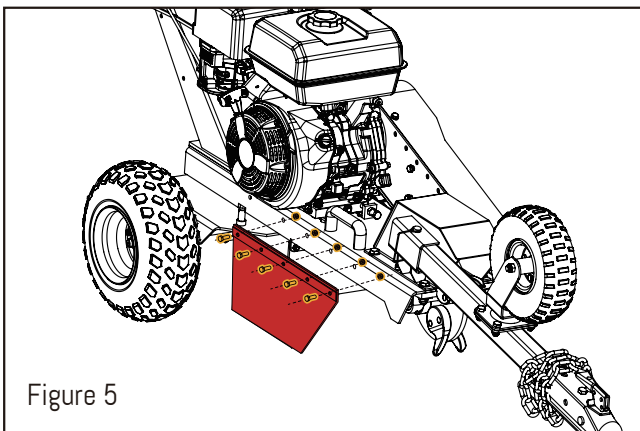

### Rubber Baffle

Install the rubber baffle to the main body of the machine with M8X25 hex bolts and M8 lock nuts.(See Figure 5)



5X	Hex lock nut M8	
5X	Hex bolt M8 X 25mm	

# KNOW YOUR MACHINE

## FEATURES AND CONTROLS

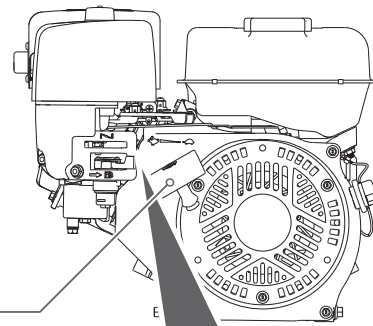
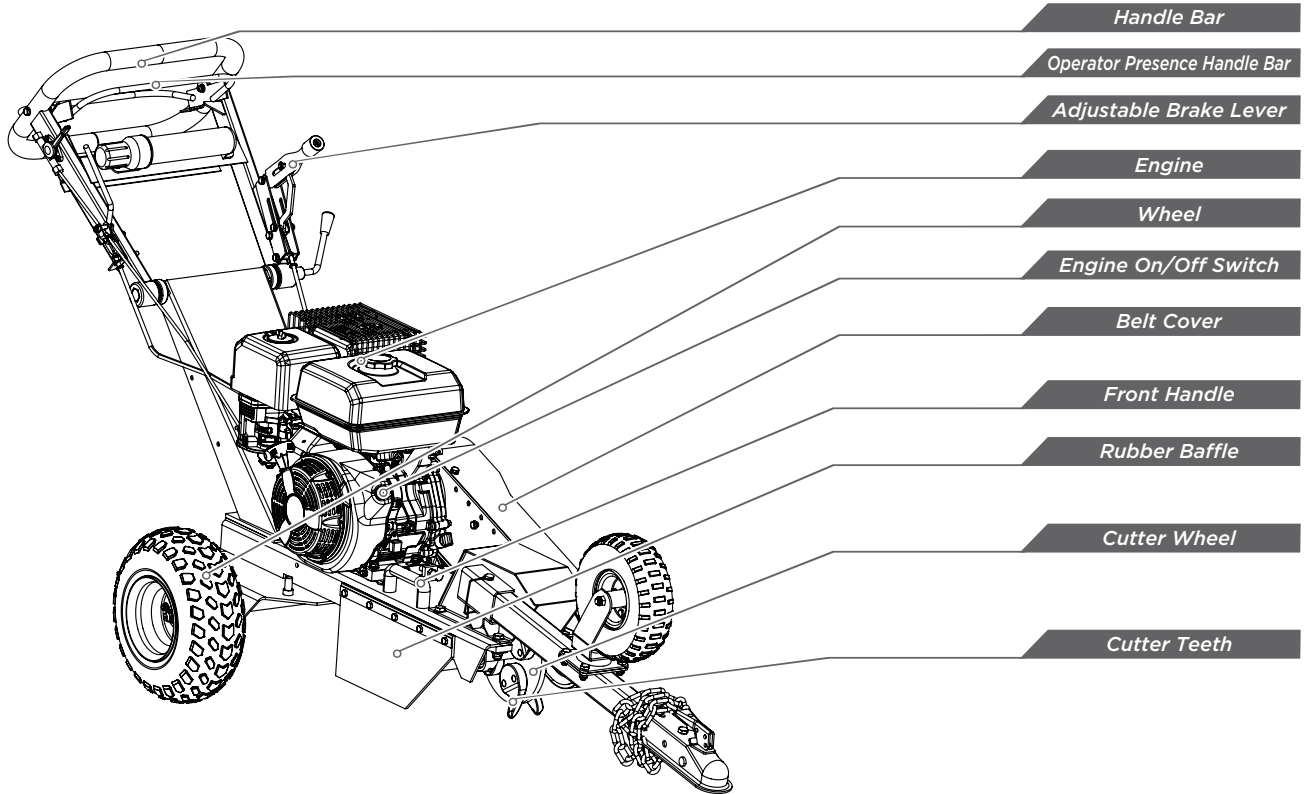

Recoil Starter Handle

Throttle Control

Choke Control

Fuel Shut-Off Valve

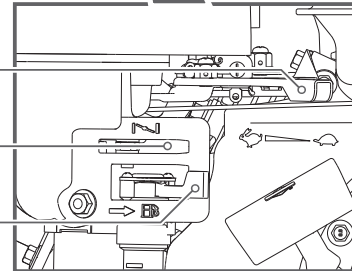

## OPERATION



**CAUTION:** Add engine crankcase oil. A new engine is shipped without oil. You must add the correct amount of oil to engine crankcase or engine will be damaged beyond repair.  
*Note: #92 gasoline fuel and 5w30 engine oil.*

Before starting the engine you will want to make sure you have completed the following:

Marking Underground Utilities.

- Checking Controls.
- Checking Cutting Teeth.
- Checking/Adding Oil.
- Filling Stump Grinder Gasoline Tank.
- Inspecting Fuel System for Leaks.
- Locking Handle Bar.
- Wearing Personal Protection.
- Trimming Stump with Saw.
- Clearing Area of People and Objects.
- Working During Daylight.
- Each of these procedures is discussed in detail below.

### Check Controls

All guards are in place and tight.

Operator presence bar switch is free moving.

Inspect tires and rims for looseness, damage, and tire inflation.

### Check cutting teeth

Inspect cutting teeth for tightness and sharpness. Only use factory-approved parts for repair.

### Check/Add oil

Check the oil level using the dipstick and add oil as needed.

Using a funnel, add oil up to the FULL mark on the dipstick with the recommended oil type for your engine and expected ambient conditions.

(See engine Owner's Manual for oil type and capacity, and more detailed oil check/fill instructions).



**WARNING: Burn Hazard**  
 Never open oil fill port while engine is running. Hot oil can spray over face and body.

### Fill stump grinder gasoline tank

Check the gasoline level in the engine's fuel tank. If needed, fill tank with fresh unleaded gasoline from a portable container, after first reading the warnings and instruction below.

- DO NOT fill the gas tank to the top. Gasoline may spill when operating on a slope.

- DO NOT overfill the gasoline tank. Allow at least 1" of empty space below the fill neck to allow for fuel expansion.

#92 gasoline fuel and 5w30 engine oil



**WARNING: Gasoline fire/explosion hazard**

Gasoline is highly flammable and explosive. Heat, sparks and flames can ignite gasoline vapors, which can become widespread during fueling. A flash fire ignition and/or explosion could result and cause serious injury or death. The following conditions could result in gasoline ignition/explosion:

- Gas vapor collection inside enclosures.
- Static electric sparks.
- Sparks from electric wiring, batteries, or running engines.
- Sources of heat (such as a hot engine or exhaust).
- Open flames, including pilot lights.

### Inspect Fuel System/Check for Leaks

Inspect fuel system & check for leaks BEFORE starting grinder.



**WARNING: Fuel leak hazard**

A leaking fuel line no matter how small can be the source of a fire or explosion when starting or operating the engine.

Inspect the entire fuel system. Look for: Signs of leaks or deterioration, chafed or spongy fuel hose, loose connections, loose or missing fuel hose clamps, damaged gasoline tank, or defective gasoline shut-off valve.

If grinder is in an enclosed area and you smell gas, DO NOT start engine! DO NOT light a match. DO NOT flip on an electrical switch. Exit area immediately leaving doors open and call fire department.

### Locking Handle Bar

Handle is capable of folding when not in use.

### Personal Protection

Use approved protective clothing and approved protective equipment when using the machine.

- Always wear safety glasses with side shields and a full-face shield.
- The use of ear plugs or other hearing protection device is also recommended for persons working within 15-20 feet (5-6.5m) of the running grinder for longer than a few minutes. Hearing can be damaged from prolonged, close-range exposure to the type of noise produced by this grinder.
- Wear long pants to protect legs from sparks, hot engine and flying debris.
- Never wear jewelry or loose-fitting clothing when starting or operating the grinder or any mechanical device. Loose or dangling apparel, jewelry or hair can become entangled in moving parts.
- Neither the machine as a whole nor its internal components are intended for use in potential explosive atmospheres.

Trim Stump with Saw	Cut or trim the stump preferably to ground level using a power saw.
Clear Area	Dig away the earth and remove any stones near the tree stump or roots that may interfere with your work.
Working During Daylight Hours	Only use the machine in daylight or in well-lit conditions. Never operate the grinder after dark.

## Starting the Grinder

After you have completed the pre-start checking list and procedures, you are ready to start the grinder.

The following directions details how to start the engine of your grinder.



**Never attempt to use the grinder without proper protective equipment, particularly eye protection and a full-face shield.**

To start the grinder:

Note: For additional engine starting instructions see your gasoline engine manual.

- Lock handle in the upright position.
- Place stump grinder into position with cutting wheel near the front-top edge of the stump.
- Use brake lever on handle to lock the wheel brake.

Note: For tighter brake adjustment, turn knob on top of brake lever. (See Maintenance & Repair sections for instructions).



**Stay in the OPERATOR POSITION (Behind the machine) while actuating controls. Never leave grinder unattended.**

- For cold engine, mover choke lever to the CLOSED position. To restart a warm engine, leave choke lever in OPEN position.
- Turn engine switch to the ON position.
- Grip operator presence bar and handle bar together in left hand.



**A rotating cutting wheel is very dangerous. Stay at the controls and keep others away until you are sure the blades has come to a complete stop.**

- Pull the starter grip lightly until you feel resistance, then pull briskly. Return the starter grip gently. If the choke lever was moved to the CLOSED position to start the engine, gradually move it to the OPEN position as the engine warms up.
- Press down on handle bar to lift cutter wheel off the ground.
- Grip throttle control lever and handle bar together in right hand. Centrifugal clutch will engage and cutter wheel will begin to rotate.

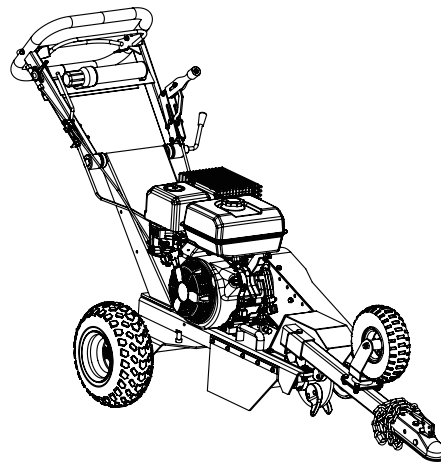

## Stopping the Engine

Stop the engine using the following steps:

- While holding blade off ground, release the operator presence bar. The engine will stop. Wait until the blade completely stops. Lower the blade so it is resting against the ground.
- Make sure brake is set before leaving the controls, particularly if you are on an incline.
- Turn engine switch to OFF position.
- Allow the engine to cool for at least 30 minutes before releasing brake and moving to storage or transporting. A hot engine can be a fire hazard.

## Grinding the Stump



**WARNING: Flying Debris Hazard**

Stones, chips, and debris can cause serious injury or property damage.

Debris can fly 75 ft (25m) in any direction out of the chute. They can bounce off any fixed objects as well and hit operator, bystanders or breakable objects.

- Set/engage the brake.
- Pivot the grinder toward the side of the stump, with a fairly light touch feed straight into the stump. As soon as you feed in, start to swing to the side until you feel the wheel drop off the edge of the stump.

Change direction and swing back the other way until you feel it reach the other edge of the stump. As you swing to the side listen to the engine. Provide enough feed to give it a moderate load. If you hear any belt or clutch squealing you are pushing too hard. If you can not swing it to the side, raise the grinder up.

You can cut roots off by plunging straight through them.

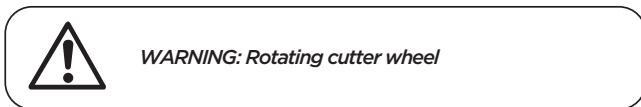

Keep hands and feet away. Contact with wheel rotating teeth will cause serious personal injury.

- When grinding larger stumps, chips may begin to build up under the wheel.
- Release brake and pull machine towards you so that the "chip pile" is directly under the cutting wheel.
- Drop cutter wheel down on "Chip pile", material will be discharged from machine area.

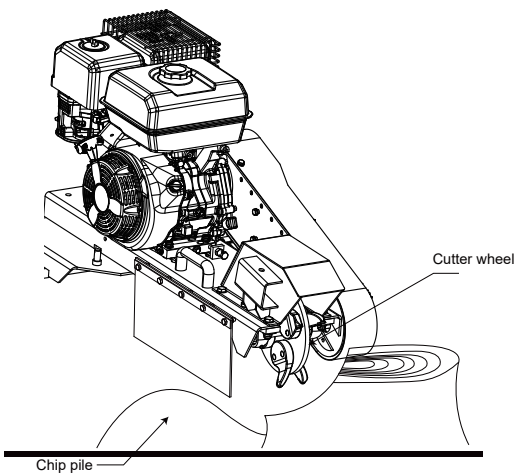

Stones, chips, and debris can cause serious injury or property damage.

Debris can fly 75 ft (25m) in any direction out of the chute. They can bounce off any fixed objects as well and hit operator, bystanders or breakable objects.

- On these large stumps, DO NOT allow grinder wheels to drop into stump hole. If a hole is in the way of your progress, fill it with chips or change position.

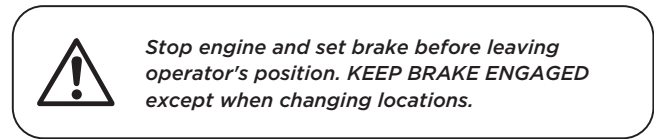

- When finished, stop the engine.
- Pull machine away from stump, and rack chips away from stump.

### Refueling

- Before removing gas cap, turn engine off and allow to cool for at least two minutes.

Note: A running or hot engine can ignite fuel.

- Remove grinder gasoline cap.
- Add gasoline through the fill opening
- Use only an portable gasoline container to transfer the gasoline to the grinder's tank.
- Be aware of safety warning and instructions below for avoiding static electric caused fires.
- Do not overfill.



A static electric spark can explosively ignite gasoline vapor, resulting in a flash fire that could cause serious injury or death. See "Special Safety Information on Static Electricity" at end of this manual.

- Clean up gasoline spills / splashes immediately.
  - If possible, move the grinder away from spilled gasoline on the ground.
  - Wipe up spilled gasoline, and wait 5 minutes for excess gasoline to evaporate before starting engine.
  - Gasoline soaked rags are flammable and should be disposed of properly.
  - If gasoline is spilled on your skin or clothes, change clothes and wash skin immediately.
- Replace gasoline cap securely before starting engine.
  - Store extra gasoline in a cool, dry place in an tightly sealed container.
  - Filling towable units or portable containers at service stations: Even if you have a towable unit, avoid static electric sparking while filling the gasoline tank:
    - Never fill the grinder's gas tank directly from the fuel pump. The grinder's tank is not grounded and high velocity flow from the pump can cause static electricity build-up. Use an portable container to transfer gas to the grinder's tank.
    - Use a portable container made of metal or conductive plastic. This is preferred because it dissipates static charge to ground more readily.
    - Never fill a portable gas container while it is sitting inside a vehicle, trailer, trunk, or pick-up truck bed. ALWAYS place container on the ground to be filled.
    - Keep nozzle in contact with container while filing. Do not use a nozzle lock-open device.

### Storing the Machine

When you are finished using the grinder and it has cooled, you must:

- Cool engine before storage.
- Clean the grinder.
- Inspect for worn or damaged parts.
- Choose covered storage location.
- Prevent accidental starting.
- Plan on exercising the engine at least monthly unless the grinder is prepared for long term storage.

Detailed instructions are provided below.

Cool Engine	Let engine cool for at least 30 minutes before storing. A hot engine can be a fire hazard.
-------------	--

Clean Grinder	Clean all grease, dirt, mud and other foreign matter from the machine. Touch up paint damage to prevent rust.
Inspect Grinder	Inspect the machine for worn or damaged parts and tighten any nuts or screws that may have become loose. Pay particular attention to the cutting teeth.
Choose a Storage Location	Store the grinder in a location that is: <ul style="list-style-type: none"> <li>• Clean and dry</li> <li>• Away from sources of heat, open flames, sparks, or pilot lights, even if the grinder's gas tank is empty. Residual gasoline could ignite.</li> <li>• Away from extreme high or low temperatures.</li> <li>• Cover it for extra protection.</li> </ul>

### Remove Spark Plug

Remove spark plug, in order to ensure the grinder cannot be started in a storage location or by untrained persons or children.

### Start Grinder Every 4 Weeks

The grinder should be started regularly. At least every 4 weeks, start the engine and let it run for 10 to 15 minutes. Monthly exercising of the grinder will dry out any moisture that has accumulated, lubricate cylinders, and clean out old gas in the carburetor. Moisture, old gas, and dry mechanical parts cause deterioration in stored engines.

### Prepare Engine for Long Term (Seasonal) Storage if needed

If you will not be able to start the grinder regularly, you must prepare the engine for long term storage to prevent gum deposits from forming and causing malfunction of the engine.

Prepare engine for long term storage by:

- Removing all gasoline from the tank and carburetor
- OR
- Adding fuel stabilizer to the gasoline (following manufacturer's instructions)

Fuel stabilizer steps:

1. Ensure gas tank is full.
2. Add fuel stabilizer to fuel tank.
3. Run engine at least 10 minutes after adding stabilizer to allow it to enter the fuel system.
4. Shut off engine.
5. Disconnect spark plug wire and remove spark plug.



6. Add one teaspoon oil through spark plug hole.
7. Place rag over spark plug hole and turn starter (or pull the recoil) a few times to lubricate the combustion chamber.
8. Replace spark plug, but do not reconnect the spark plug wire.

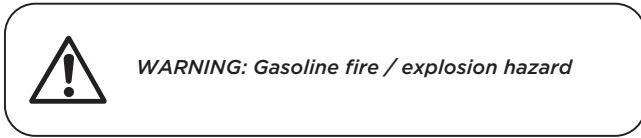

Gasoline is highly flammable and explosive. Drain the fuel into an approved container OUTDOORS and far away from open flame. NEVER store an engine with fuel in the tank indoors or in poorly ventilated spaces where fuel vapor can come in contact with

- Static electric sparks.
- Sparks from electric wiring, batteries, or running engines.
- Sources of heat (such as a hot engine or exhaust).
- Open flames, including pilot lights.

## WARNING

ALWAYS shut off the engine, make sure the engine is cool, and disconnect the spark plug before cleaning, adjusting, or servicing the grinder. Make sure all guards and shields are replaced before using.

## MAINTENANCE

### Perform regular Maintenance

Perform periodic maintenance as directed in this manual to keep the grinder in safe working condition.

#### Follow Safety Rules

Read and follow these safety rules whenever you will be servicing the grinder:

- Turn off grinder. Always turn off grinder and remove spark plug or spark plug wire before working on the engine or grinder to prevent accidental starting.
- Replace guards/shields. Make sure all guards and shields are replaced after servicing the grinder.
- Burns. Muffler will be hot even after unit is stopped. Allow unit to cool before servicing.
- Repair. Major service, including the installation or replacement of parts, should be performed only by a qualified electrical service technician.
- Replacement parts. If a part needs replacement, only use factory approved repair parts. Replacement parts that do not meet specifications may result in a safety hazard or poor operation of the grinder and will void the warranty.

### Perform Engine Maintenance

Perform engine maintenance as specified in the engine owner's manual.

Engine maintenance items include:

- Oil and oil filter changing
- Air filter check/replacement
- Spark plug cleaning and replacement
- Fuel filter check/replacement
- Fuel tank cleaning.

### Inspect Fuel System / Check for Leaks

Inspect the fuel system and check for leaks on a regular basis. Look for: signs of leaks or deterioration, chafed or spongy fuel hose, loose connections, loose or missing fuel hose clamps, damaged gasoline tank, or defective gasoline shut-off valve.

### Lubricate

Cutter shaft bearings should be greased.

The cutter shaft bearing is greased by pumping grease into zerks located on the housing of the bearing. Lubricate after every 20 hours of use.

Grease Specifications	
Soap Type	Lithium Complex
NLGI Grade	#2
Dropping Point	230°C (446°F)
Additives	Corrosion and Oxidation inhibitors, EP optional
Viscosity Index	80 Minimum

### Check and Adjust Brake

Check that the brake is functioning properly.

- Lock the brake, push down on handle bar so that cutter wheel is off the ground.
- Push or pull the grinder- if the brake is loose, the wheel will rotate.

To adjust braking tension:

- Unscrew set screw.
- Turn knob clockwise to increase tension or counter-clockwise to decrease tension.
- Once you have set the brake to the proper tension, tighten set screw to lock adjustment knob.

## Belt Tension Adjustment

Note: Belt tension and alignment are inter-related. Do not adjust one without checking the other.

- Remove belt guard.
- Loosen (4) engine base (mount) bolts.
- Loosen lock nuts on tension bolt and alignment bolt.
- Turn tension bolt clockwise to increase belt tension and counterclockwise to decrease belt tension.
- Check that the pulleys are aligned using a straight edge. To achieve proper pulley alignment you may need to adjust the alignment bolt. This bolt will serve as an adjustment point to counter the tension in the belts, which may cause the engine pulley to be misaligned with the cutter wheel pulley. Note: Set screws in pulley have a torque specification of 25.3kg/m.
- Belt tension is proper when a 2.27kg to 3.18kg force will deflect the belt 2/5" (1cm) at the midpoint.
- Retighten all loosened nuts and bolts.
- Reassemble belt guard.
- Belt tension is proper when a 2.27kg to 3.18kg force will deflect the belt 2/5" (1cm) at the midpoint.
- Retighten all loosened nuts and bolts.
- Reassemble belt guard.

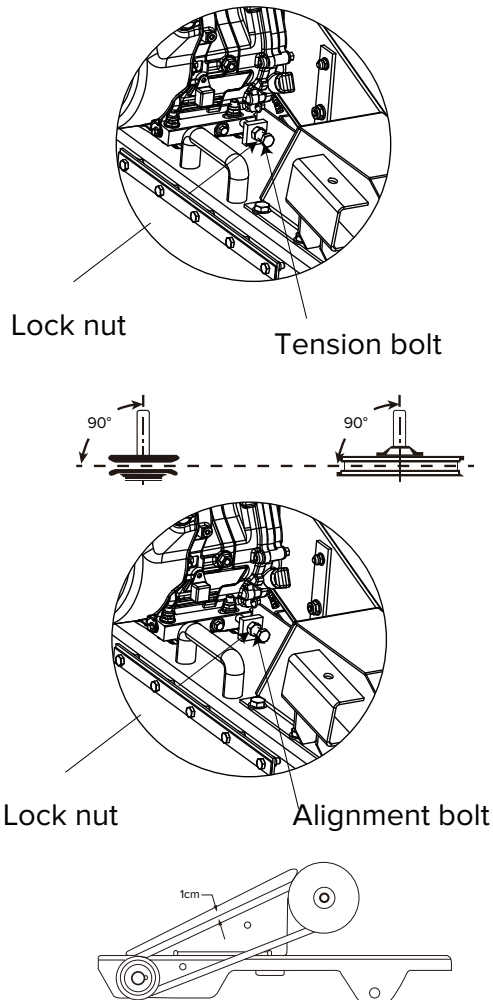

## Stop-Switch Adjustment



**Never attempt to alter, modify or override this switch.**

Never attempt to alter, modify or override this switch.

If stop-switch ever needs to be replaced or adjusted follow the below directions.

1. Loosen Hex Nut.
2. Turn the Linkage Bolt clockwise to lower or counter-clockwise to raise the point of interaction with Stop Switch. To set the proper interaction distance, grip the Operator Presence Bar & Handle Bar together and lower the Linkage Bolt onto the Switch Button until the switch button cannot be depressed any further. Then raise the linkage bolt one turn (counterclockwise).
3. Tighten Hex Nut.
4. Verify operability of stop switch before operating machine by releasing the operator presence bar next to the handle bar. You should hear a "CLICK", signifying that the Linkage Bolt has been adjusted properly.

## Installing Teeth

Among the most critical elements of the stump grinder is the cutting wheel. It is also the most subject to damage and wear. In the course of grinding stumps it not only makes contact with the wood, but also encounters numerous abrasives and objects in the stump's environment, such as dirt, stones, large rocks and buried scrap.

The loss and wear of cutting teeth can significantly impair the efficiency and performance of the stump grinder. Therefore, it is important to make frequent inspections of the condition of all the cutting teeth and to replace any damaged or worn teeth

Thread in the bolt through the cutter wheel and into the teeth as shown, then tighten. Bolt should be torque to 60ft/lbs.

## Maintenance Schedule



**Before attempting any maintenance, be sure that the engine is shut off, the spark plug wire is removed, and the engine is cool to the touch!**

Item (What to check or action req'd)	Daily	Each Use	10 hours	20 hours	40 hours
Bearing, Shaft-Grease				X	
Belt Tension-Tension					X
Bolts-Tightness			X		
Engine	See manual				
Gasoline-Amount		X			
Safety Switch-Operation		X			
Warning Decals-Legible	X				
Tires, Flaps-Condition	X				
Wires, Cables-Condition		X			
Cutter Teeth-Sharpness		X			



**IMPORTANT:**

*If a part needs replacement, only use parts that meet the manufacturer's specifications. Replacement parts that do not meet specifications may result in a safety hazard or poor operation of the grinder.*

## IMPORTANT SAFETY INFORMATION

A-weighted sound power level emitted by the machine: 103.8dB for model SGR1500.

A-weighted emission sound pressure level at the operator's station: 90.8dB for model SGR1500.

The vibration total value to which the hand-arm system is subjected, less than 6.9 m/s<sup>2</sup> for model SGR1500

The range of temperature in which the machine is intended to operate and be stored is 5-40°C;

### Summary of Import Safety Information

This section provides a summary of the various safety procedures and measures that have been presented throughout the manual. Keep this summary handy and refer to it to refresh your memory about how to safely use your grinder.

### WARNING

Carefully read and make sure you understand the following safety information before using the grinder. Improper use or maintenance of the grinder can result in serious injury or death from fire/explosion, carbon monoxide poisoning, lacerations, entanglement or burns. Damage can also occur to windows, siding, vehicles, and bystanders from chips and debris which can become projectiles.

### General

- Read manual. Read this Owner's Manual and the engine Owner's Manual completely before attempting to use and service the grinder. Serious injury or death can result if safety instructions are not followed.
- Instruct operators. The grinder owner or rental company must instruct all operators in safe grinder set-up and operation. Do not allow anyone to operate the grinder who has not read the Owner's Manual and been instructed on its safe use. Make sure Owner's manual is within the attached storage tube on the grinder.
- Adults only. Only trained adults should operate and service the grinder. Do not let children operate.
- Under the influence. Never operate, or let anyone else operate, the grinder while under the influence of alcohol, drugs, or medication.
- Intended use. Carefully read about and understand the intended use of this grinder. Do not use for other purposes, as unforeseen hazards or equipment damage may result.
- Controls and safety labels. Learn how to use the machine and its controls safely. Understand and follow all safety labels.
- Weather. Never use in foul, bad or questionable weather, which causes a slippery ground condition.

## Prohibition Against Modifications

Never modify or alter the grinder in any way. Modifications can create serious safety hazards and will also void the warranty.

- Fuel/exhaust system. Never modify the exhaust system, fuel tanks, or fuel lines. Carbon monoxide poisoning, fire, or explosion could result.
- Guards. Do not operate grinder unless all guards and cover shields, which prevent access to moving parts and pinch points, are in place. Failure to guard the power transmission mechanisms may result in serious injury or death.

## Safety - Before Use

### Know how to operate

- Review safety rules. Before use of this grinder, review the "Rules for Safe Operation."
- Know how to operate. Be thoroughly familiar with all controls and with the proper use of the equipment. Know how to stop the grinder quickly if needed.

### Getting Ready

- Flying debris. Clear area of objects such as stones, toys, steel wire, etc. that could become caught in moving machine parts and ejected as a projectile.
- Operate OUTSIDE only – dangerous carbon monoxide exhaust! Grinders give off carbon monoxide exhaust, a poisonous gas that can kill. You CANNOT smell it, see it, or taste it. ONLY run grinder OUTDOORS and at least 20 feet (6m) from the home, away from windows, vents and air intakes, to allow proper ventilation. If you start to feel sick, dizzy, or weak while using the grinder, shut off the engine and get to fresh air RIGHT AWAY. NEVER run grinder engine inside homes, garages, sheds, or other semi-enclosed spaces. These spaces can trap poisonous gases.
- Cooling ventilation. The grinder needs adequate, unobstructed flow of air to allow for proper cooling of engine and grinder head. Do not allow debris to accumulate and block airflow.
- Transporting. During transporting, take precautions to make sure stump grinder will not tip over and cause a fuel leak hazard.
- Hot exhaust - fires. Exhaust from engine can be extremely hot and cause fire. Position muffler at least 7 feet (2m) from combustible objects during operation.

### Personal protective equipment

- Hearing protection. The use of ear plugs or other hearing protection device is recommended for those in close proximity to the grinder while it is operating.
- Eye protection. Wear approved eye protection when operating the grinder.
- Face protection. A helmet with a full face visor or mesh visor with protective glasses is recommended.
- Loose / dangling. Loose or dangling apparel, jewelry or hair can become entangled in moving parts. Never wear jewelry or loose-fitting clothing when operating the grinder.
- Long pants. Wear long, heavy-duty pants to protect legs from ejected materials.

## Gasoline Safety

Gasoline is highly flammable and explosive. You can be burned or seriously injured when handling fuel. Use extreme care when handling gasoline:

- Fuel outdoors. Fill fuel tank outdoors – never indoors. Gasoline vapors can ignite if they collect inside an enclosure. Explosion can result.
- Use approved container. Never pump fuel directly into engine at gas station. Static charge can build and ignite fuel. Use an UL approved fuel container to transfer gas to the engine.
- Running / hot engine. A running engine is hot enough to ignite fuel. Never add fuel or remove gas cap if engine is running or still hot. Stop the engine and allow to cool at least two minutes before adding fuel.
- Heat / flames / sparks. Keep sources of heat, flame, or sparks away while adding fuel.
- Don't fill to the top DO NOT overfill the gas tank. Allow at least 1" of empty space below the fill neck to allow for fuel expansion and operation on slopes.
- Don't fill to the top. Do not fill the gas tank to the top. Gasoline may spill when operating on a slope.
- Replace cap. Replace gas cap securely before starting engine.
- Spills. Clean up fuel spills immediately. Move grinder away from spilled fuel on the ground. Wipe fuel off engine and wait 5 minutes for excess fuel to evaporate before starting engine. Gas soaked rags should be disposed of properly.
- On skin / clothes. If gasoline is spilled on your skin or clothes, change clothes and wash skin immediately.
- Inspect fuel system. Check fuel system on a regular basis. Look for signs of leaks, deterioration, chafed or spongy fuel hose, loose or missing fuel hose clamps, damaged fuel tank, or a defective fuel shut-off valve. Do not start grinder until needed repairs have been completed.
- Gasoline storage. Store gasoline in a cool, dry place in an UL-approved, tightly sealed container away from children.

## Safety - During Use

- Safety equipment / controls. Always operate the grinder with all safety covers, guards, and barriers in place and in good working order, and all controls properly adjusted for safe operation.
- Controls. Stay in the OPERATOR POSITION while actuating controls.
- Know how to stop. Know how to stop the grinder quickly if needed by releasing the operator presence bar. If this does not work, do the following in order until unit is stopped. 1. Push the stop button on the control panel. 2. Use on/off switch on engine (or ignition switch on electric start models). 3. Engage full choke by flooding the engine.
- "Kickback". Machine can experience significant "kickback" when operating or first coming into contact with the stump.
- Slipping/Falling. Operating in wet or icy conditions could lead to losing your footing and slipping or falling.

- **Damaged.** Do not operate the grinder with damaged, missing, incorrectly adjusted, or broken parts.
- **Check for gas leak before starting.** After opening gasoline valve, smell for gas before starting engine. If you smell gas, DO NOT start engine. DO NOT light a match. DO NOT flip on an electrical switch. Exit area immediately and call fire department.
- **Carbon monoxide exhaust.** The running engine gives off carbon monoxide, a poisonous gas that can kill you. You CANNOT smell it, see it, or taste it. If you start to feel sick, dizzy, or weak while using the grinder, shut off the engine and get to fresh air RIGHT AWAY. See a doctor. You may have carbon monoxide poisoning.
- **Other exhaust dangers.** This product contains or emits chemicals to cause cancer, birth defects or other reproductive harm. Avoid inhalation of exhaust.
- **Smoking/sparks.** Never smoke near the running grinder, and never operate near sources of sparks or flames.
- **Hot muffler.** Never touch hot muffler or hot exhaust manifold. Exhaust and engine parts can be very hot and will burn you.
- **Machine's moving parts.** Keep hands, feet, and apparel away from drive belts, cutter wheel, and other moving parts. Never remove any drive belt or guard while the unit is operating. Contact with belt or rotating teeth will cause personal injury.
- **Refueling.** DO NOT refuel the engine until it has cooled at least 30 minutes.
- **Malfunction during operation.** Always shut the machine off if any unusual noise or vibration occurs.
- **Vibration.** Overexposure to machine vibration on a daily basis may lead to circulatory or nerve damage.
- **Adjusting / repairing.** Always turn off grinder and remove spark plug or spark plug wire before working on the grinder to prevent accidental starting.
- **Cleaning the Jam:** If the machine is jammed, stop the engine and remove the sparkplug wire before attempting to clear any jams in the unit. Stop all work, turn off stump grinder, unplug spark wire and ensure the engine is turned off and cooled before performing any diagnostics or repairs.

### Safety - After Use

- **Cool engine before storing.** Let engine cool for at least five minutes before storing. A hot engine can be a fire hazard.
- **Shut off fuel supply.** Make sure gasoline shut-off valve is in the OFF position.
- **Prevent accidental starting.** When grinder is not in use, remove key from starter (electric start engines) and secure in a safe location, or remove spark plug in order to ensure that grinder cannot be started in a storage location or by untrained persons.
- **Storage location.** Store the grinder in a dry location away from sources of heat, open flames, sparks or pilot lights – such as water heaters, space heaters, furnaces, clothes dryers, or other gas appliances – EVEN IF the grinder's gas tank is empty. Residual gasoline could ignite.
- **Exercise regularly.** Exercise grinder every four weeks to dry out moisture that accumulates in the windings. If grinder cannot be exercised on a regular basis, prepare grinder for long term storage.

### Safety - Inspection / Maintenance

Inspect and maintain your grinder on a regular basis and repair as needed to keep it in safe working condition:

- **Turn off grinder.** Always turn off grinder and remove spark plug or spark plug wire before working on the engine or grinder to prevent accidental starting.
- **Replace guards / shields.** Make sure all guards and shields are replaced after servicing the grinder.
- **Burns.** Do not touch hot muffler. Muffler will be hot even if unit is stopped. Allow unit to cool before servicing.
- **Replacement parts.** If a part needs replacement, only use parts that meet the manufacturer's specifications. Replacement parts that do not meet specifications may result in a safety hazard or poor operation of the grinder and will void the warranty.

### Special Safety Information on Static Electricity

**Static electricity and filling gasoline:**  
**Static electricity can initiate from ungrounded gasoline tanks or containers, from flowing gasoline, and from persons carrying a static electric charge**

Static electricity on numerous occasions has explosively ignited gasoline vapors that were present during fueling processes, resulting in serious burns to nearby persons. To avoid static electricity while fueling, certain steps must be followed before and during the fueling process in order to minimize and safely dissipate static charge build-up.

Filling Portable Containers at Service Stations:

Use a portable container to fill grinder tank. Never fill the grinder's gas tank directly from the service station's fuel dispenser pump – the grinder's tank is not grounded and the high velocity flow of gasoline from a fuel pump can cause static electric build-up. Use an approved portable container to transfer gasoline to the grinder's tank.

- Use a portable container made of metal or conductive plastic. It will dissipate charge to ground more readily.
- Fill container on the ground. Never fill the portable gas container while it is sitting inside a vehicle, trailer, trunk, or pick-up truck bed. ALWAYS place container on the ground to be filled.
- Touch a grounded metal object before starting. Always dissipate static charge from your body before beginning the fueling process by touching a grounded metal object at a safe distance away from fuel sources.
- Keep nozzle in contact with container. Keep fuel dispenser nozzle in contact with the portable container at all times while filling at a service station. Do not use the nozzle lock-open device on the dispenser hose.

## TRANSPORTATION

The stump grinder is designed to be transported via a van or small trailer. The machine is equipped with grab bars that are to be used for both lifting the machine, and strapping it down. This machine weighs approximately 110kg and should only be lifted using correct apparatus or an adequate number of people working as a team.

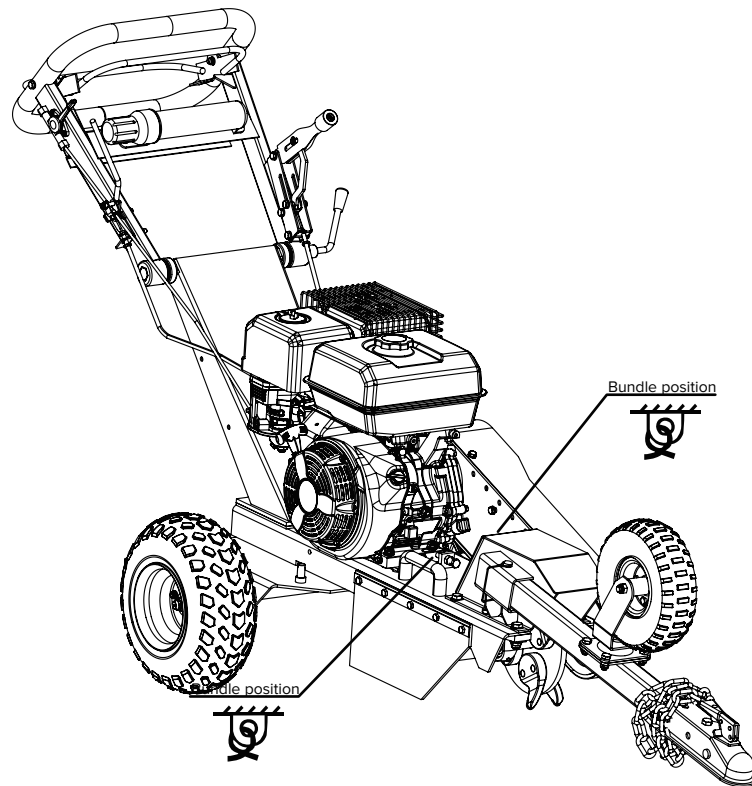

**Note:**

Lift the machine at the point of lift label shown.

Tie the machine at the point of tying label when transport for long distance to keep the machine stable.

There are legal road requirements for towing equipment and trailers (such as lighting and licensing). It is the owner's responsibility to be aware of these laws and to adhere to them.

