

# Electrical WheelBarrow

## Operator's Manual

**MODEL NUMBER :**

**SERIAL NUMBER :**

Both model number and serial number may be found on the main label.  
You should record both of them in a safe place for future use.

### FOR YOUR SAFETY

**READ AND UNDERSTAND THE ENTIRE MANUAL BEFORE  
OPERATING MACHINE**

# TABLE OF CONTENTS

Introduction	2
Specifications	2
Symbols	2
Personal safety	3
Power tool use and care	4
Battery tool use and care	4
Specific Safety Rules	5
Service	5
CONTENTS SUPPLIED	6
ASSEMBLY	7
KNOW YOUR PIWEREDWHEELBARROW	8
Electrical Wheelbarrow Operation	9
Maintenance	13
Storage	13
Disposal warnings	13
Trouble Shooting	14

## INTRODUCTION

Your new electric powered barrow will more than satisfy your expectations. It has been manufactured under stringent quality standards to meet superior performance criteria. You will find it easy and safe to operate, and with proper care, it will give you many years of dependable service.



**Carefully read through this entire operator's manual before using this unit. Take special care to heed the cautions and warnings.**

## Specifications

Loading capacity	1000W 48V brushless DC motor
Brack system	Electromagnetic brake
Battery	48V 20Ah/32Ah lead-acid battery
Battery Life	8-10hrs
Charging Time	6-7hrs
Operating load	1105 lbs
Payload capacity	8.34 cu ft
Tipping	Manual; Air spring
Reverse speed	0-0.93mph
Forward speed	High speed 0-3.1mph
	Middle speed 0-2.6mph
	Low speed 0-2.1mph

## ENVIRONMENTAL



Recycle unwanted materials instead of disposing of them as waste. All tools, hoses and packaging should be resorted, taken to the local recycling center and disposed of in an environment-friendly safe way.

## SYMBOLS

The rating plate on your machine may show symbols. These represent important information about the product or instructions on its use.



**Coution!** Ignoring the safety signs and warnings applied on the machine as well as ignoring the security and operating instrutions can cause serious injuries and even lead to death.



Read these instructions carefully.



Wear eye protection.  
Wear hearing protection.



Wear protective gloves.



Wear safety footwear.



When reversing, idling the engine, act slowly on the clutch lever, make sure that there are no barriers behind you.



Keep your hands and feet distance from the tracks



Either sitting on the machine and carrying people is forbidden.



To avoid injury during maintenance, maintenance work may only be done while the dumper is on safe ground and safely locked.



Do not operate the utility machine in the rain.



Keep your hands clear from all rotating parts.



Keep bystanders away.



Keep away from hot parts on the machine.



Do not use for transporting persons.



Do not stare at operating lamp.



WARNING Pinch and crush hazard. Keep hands clear during operation.

# SAFETY

## General Safety Rules

### Understand Your Machine

Read and understand the operator's manual and labels affixed to the machine. Learn its application and limitations as well as the specific potential hazards peculiar to it.

Read all safety warnings, instructions, illustrations and specifications provided with this power tool. Failure to follow all instructions listed below may result in electric shock, fire and/or serious injury. Save all warnings and instructions for future reference. The term "power tool" in the warnings refers to your mains-operated (corded) power tool or battery-operated (cordless) power tool.

### Work area

- a) Keep work area clean and well lit. Cluttered or dark areas invite accidents.
- b) Do not operate power tools in explosive atmospheres, such as in the presence of flammable liquids, gases or dust. Power tools create sparks which may ignite the dust or fumes.
- c) Keep children and bystanders away while operating a power tool. Distractions can cause you to lose control.

### Personal safety

- a) Stay alert, watch what you are doing and use common sense when operating a power tool. Do not use a power tool while you are tired or under the influence of drugs, alcohol or medication. A moment of inattention while operating power tools may result in serious personal injury.
- b) Use personal protective equipment. Always wear eye protection. Protective equipment such as a dust mask, non-skid safety shoes, hard hat or hearing protection used for appropriate conditions will reduce personal injuries.
- c) Prevent unintentional starting. Ensure the switch is in the off-position before connecting to power source and/or battery pack, picking up or carrying the tool. Carrying power tools with your finger on the switch or energising power tools that have the switch on invites accidents.
- d) Remove any adjusting key or wrench before turning the power tool on. A wrench or a key left attached to a rotating part of the power tool may result in personal injury.
- e) Do not overreach. Keep proper footing and balance at all times. This enables better control of the power tool in unexpected situations.

f) Dress properly. Do not wear loose clothing or jewellery. Keep your hair and clothing away from moving parts. Loose clothes, jewellery or long hair can be caught in moving parts.

g) If devices are provided for the connection of dust extraction and collection facilities, ensure these are connected and properly used. Use of dust collection can reduce dust-related hazards.

h) Do not let familiarity gained from frequent use of tools allow you to become complacent and ignore tool safety principles. A careless action can cause severe injury within a fraction of a second.

i) Do not operate the utility machine in the rain. This may result in the loss of control, slipping and falling which may increase the risk of personal injury.

### **Power tool use and care**

a) Do not force the power tool. Use the correct power tool for your application. The correct power tool will do the job better and safer at the rate for which it was designed.

b) Do not use the power tool if the switch does not turn it on and off. Any power tool that cannot be controlled with the switch is dangerous and must be repaired.

d) Store idle power tools out of the reach of children and do not allow persons unfamiliar with the power tool or these instructions to operate the power tool. Power tools are dangerous in the hands of untrained users.

e) Maintain power tools and accessories. Check for misalignment or binding of moving parts, breakage of parts and any other condition that may affect the power tool's operation. If damaged, have the power tool repaired before use. Many accidents are caused by poorly maintained power tools.

g) Use the power tool, accessories and tool bits etc. in accordance with these instructions, taking into account the working conditions and the work to be performed. Use of the power tool for operations different from those intended could result in a hazardous situation.

h) Keep handles and grasping surfaces dry, clean and free from oil and grease. Slippery handles and grasping surfaces do not allow for safe handling and control of the tool in unexpected situations.

### **Battery tool use and care**

a) Recharge only with the charger specified by the manufacturer. A charger that is suitable for one type of battery pack may create a risk of fire when used with another battery pack.

b) Use power tools only with specifically designated battery packs. Use of any other battery packs may create a risk of injury and fire.

c) When battery pack is not in use, keep it away from other metal objects, like paper clips, coins, keys, nails, screws or other small metal objects, that can make a connection from one terminal to another. Shorting the battery terminals together may cause burns or a fire.

d) Under abusive conditions, liquid may be ejected from the battery; avoid contact. If contact accidentally occurs, flush with water. If liquid contacts eyes, additionally seek medical help. Liquid ejected from the battery may cause irritation or burns.

e) Do not use a battery pack or tool that is damaged or modified. Damaged or modified batteries may exhibit unpredictable behaviour resulting in fire, explosion or risk of injury.

f) Do not expose a battery pack or tool to fire or excessive temperature. Exposure to fire or temperature above 130 °C may cause explosion.

NOTE The temperature „ 130 °C“ can be replaced by the temperature „ 265 °F“ .

g) Follow all charging instructions and do not charge the battery pack or tool outside the temperature range specified in the instructions. Charging improperly or at temperatures outside the specified range may damage the battery and increase the risk of fire.

## Service

a) Have your power tool serviced by a qualified repair person using only identical replacement parts. This will ensure that the safety of the power tool is maintained.

b) Never service damaged battery packs. Service of battery packs should only be performed by the manufacturer or authorized service providers. Never stop the machine on a slop surface.

c) For battery tools:

1) Instructions regarding battery charging, information regarding ambient temperature range for tool and battery use and storage, and the recommended ambient temperature range for the charging system during charging;

2) For a battery-operated tool intended for use with a detachable battery pack or a separable battery pack:instructions indicating the appropriate battery packs for use,such as by a catalog number, series identification or the equivalent;

3) Instructions indicating the appropriate charger for use, such as by a catalog number,series identification or the equivalent.

Never park the machine in a place with unstable ground which could give way ,particularly when it is full.

Disengage clutch lever before starting the engine.

Start the engine carefully according to instructions and with feet well away from the moving parts.

Never leave the operating position when the engine is running.

Always hold the unit with both hands when operating .Keep a firm grip on the handlebars.Be awaer that the machine may unexpectedly bounce upward or jump forward if the machine should strike buried obstacles such as large stones.

Walk, never run with the machine.

Do not overload the machine capacity .Drive at a safe speed ,adjusting the speed to the slope of the land .the surface conditions of the road ,and the weight of the load.

Use extreme caution when in reverse or pulling the machine towards you.

Exercise extreme caution when operating on or crossing gravel drives ,walks,or roads.Stay alert for hidden hazards or traffic.

On soft ground ,drive at the first forward /reverse gear. Do not rapidly accelerate ,turn sharply or stop.

Pay the utmost attention when working on frozen ground as the machine may tend to skid.

If possible ,avoid driving on pebble river bed, crushed stone terrains, steel concrete ,stumpy field , logs etc., since such operation causes fatal damage or shortens life span of tracks.

Do not operate the machine in confined areas where there may be a risk of crushing the operator between the machine and another object.

Never operate the machine on slopes where angle is over 20°.

When moving over a slope , whether moving forward or in reverse ,always make certain that the weight is evenly balanced .Always move in directions parallel with the slope (up or down),To avoid danger ,do not shift gears on slopes.

When tipping the load from a dumper ,the center of gravity will change continuously and the ground conditions will be essential for the stability of the machine .There are special hazards for dumpers working on soft ground and when the load is sticking to body e.g. wet clay.

### Specific Safety Rules

Thoroughly inspect the area to be worked, keep the working area clean and free of debris to prevent tripping. Operate on a flat level ground.

Never place any part of your body where it would be in danger if movement should occur during assemble ,installation ,and operation ,maintenance, repairing or moving .

Keep all bystanders,children ,and pets at least 23m(75feet) away .If you are approached, stop the unit immediately .

Do not mount on dump box and never carry passengers.

# CONTENTS SUPPLIED

The Electrical wheelbarrow comes partially assembled and is shipped in carefully packed package. After all the parts have been removed from the package, you should have:

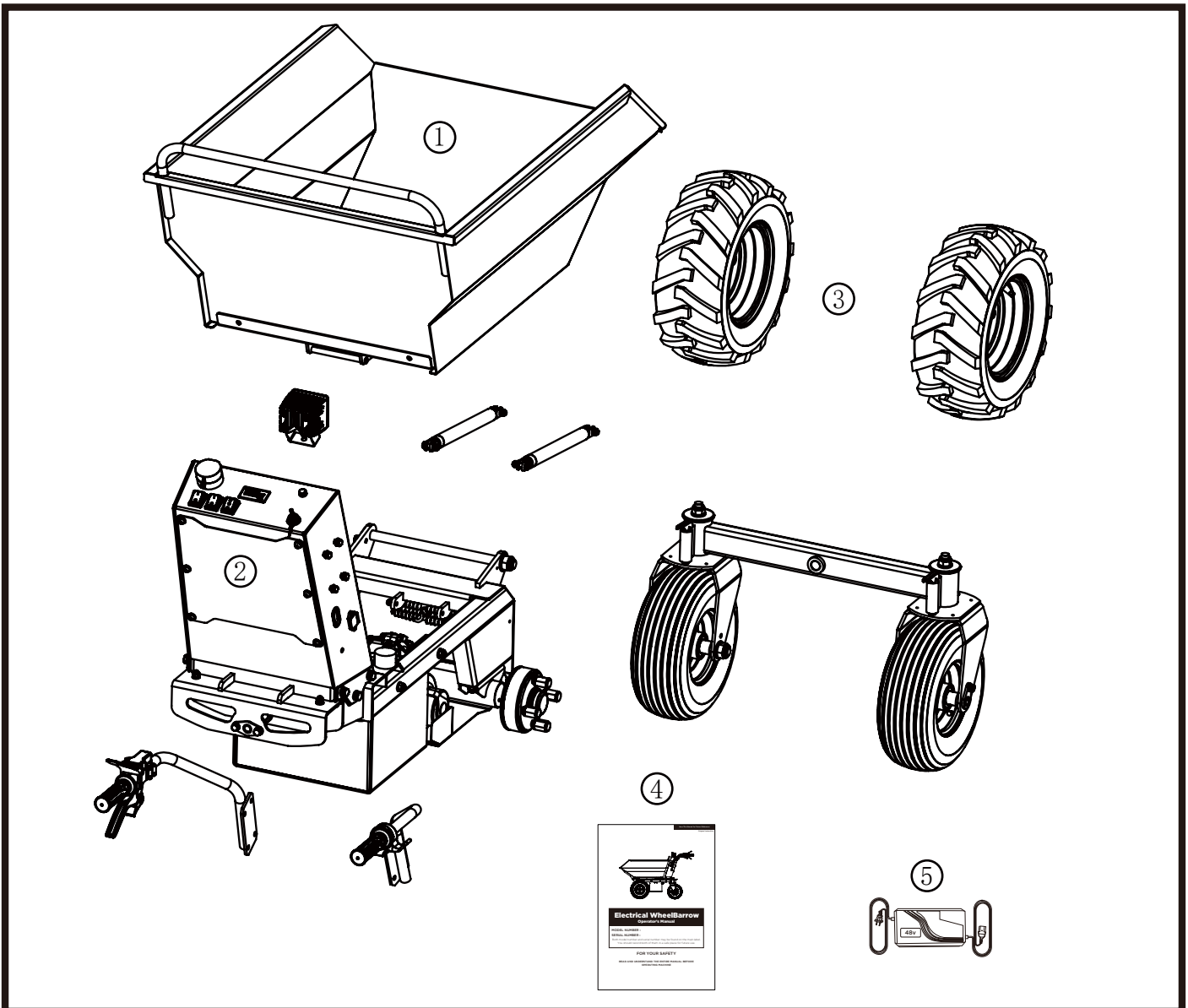

1. Dumper Box
2. Main Frame
3. Wheels
4. Operator's Manual
5. Charger

## ASSEMBLY

Following the assembly directions below, you will assemble the machine in a few minutes.

## Machina Assembly

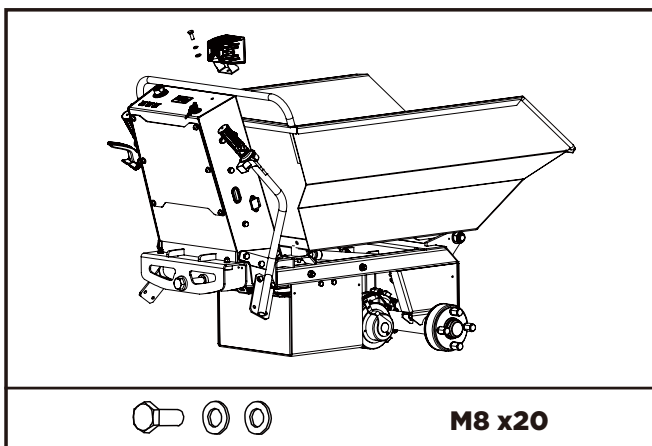

Mount the light and fasten it with M8 nuts.

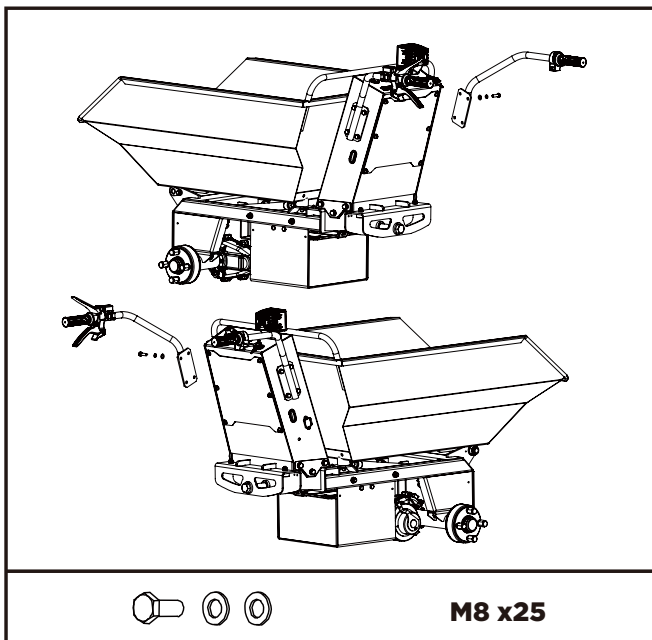

Mount the right and left handle with M8X25bolts,

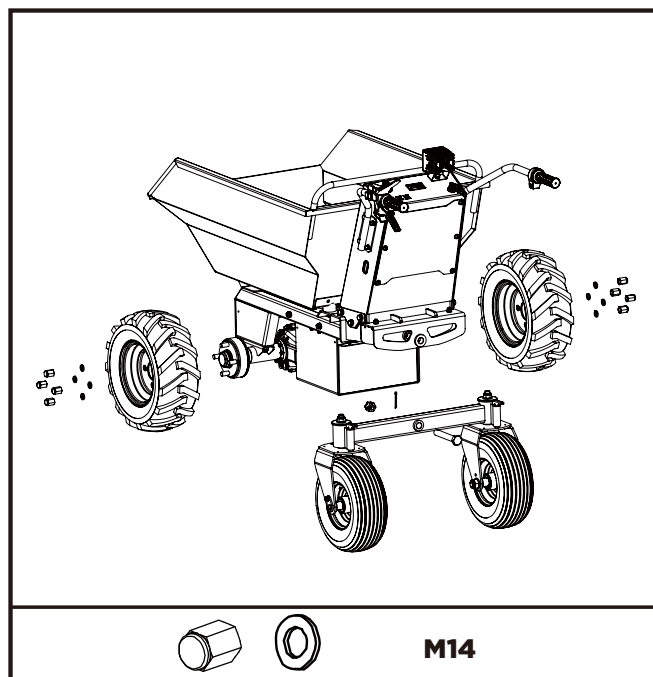

Mount the front wheels and fasten them with M14 hub nut and Spring washer 14. Mount the rear wheels and fasten them with Axle sleeve.

# KNOW YOUR ELECTRICAL WHEELBARROW

## Features and Controls

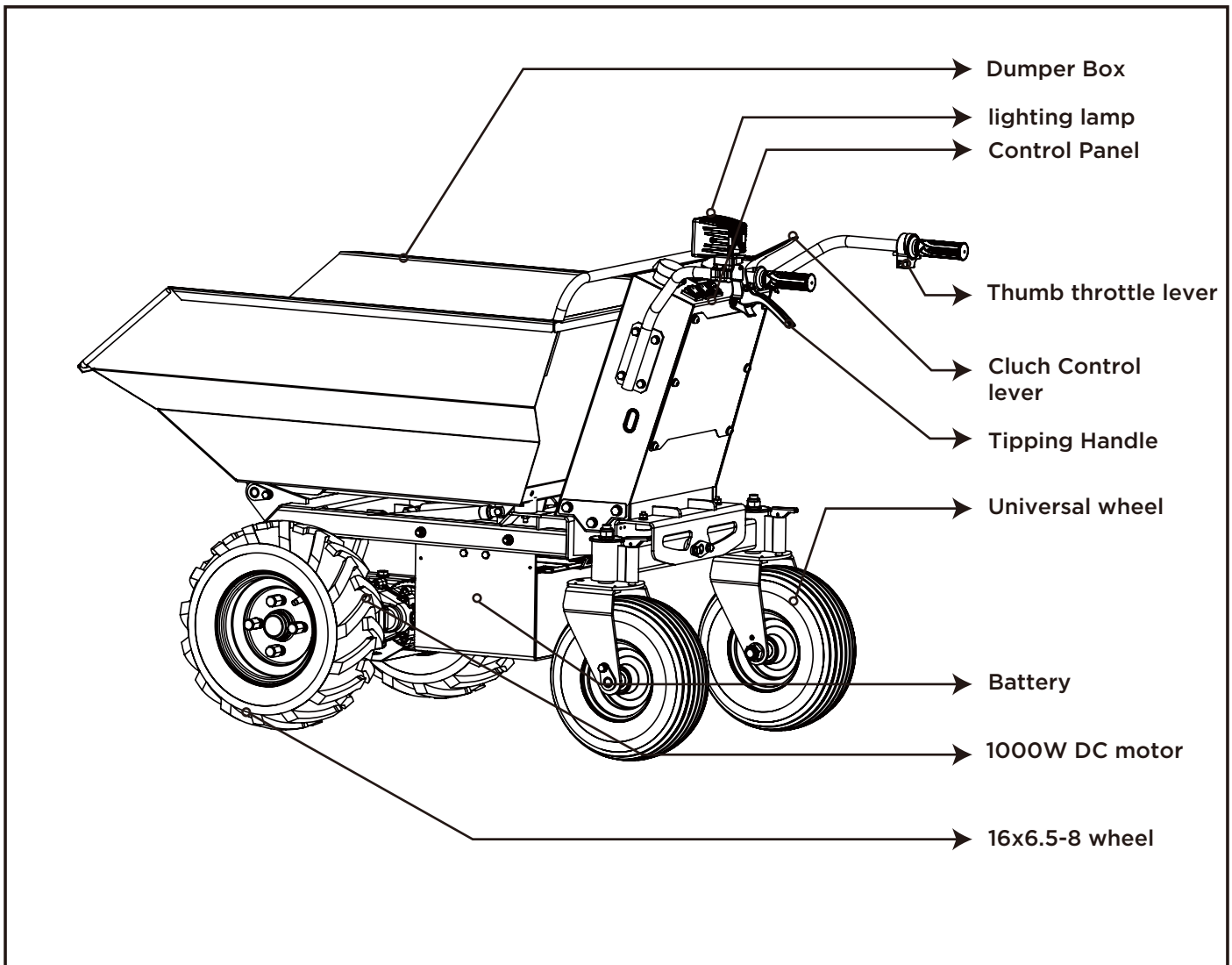

### Clutch control lever

Squeeze the control lever, clutch engaged.  
Release the lever, clutch disengaged.

### Tipping handle

It controls tipping of the dump box. Squeeze this handle when want to tip the dumper box. Detailed operations please refer to following instructions Before you start to use the dumper, please check the dump box to make sure it is locked

### Light

You can turn on the light when the light is not good.

### Forward and Reverse Button

The red button on the handle controls forward and reverse direction, when at "D" position, machine will run forward, and when pressing it to "R", machine will run backward.

### Universal Wheel

When you want to turn right or left, firmly hold the handle bar to control the Universal Wheels to turn right or left. Pull down the wheel locks showed as picture 4, the machine will run forward and backward directly.



## Control Panle

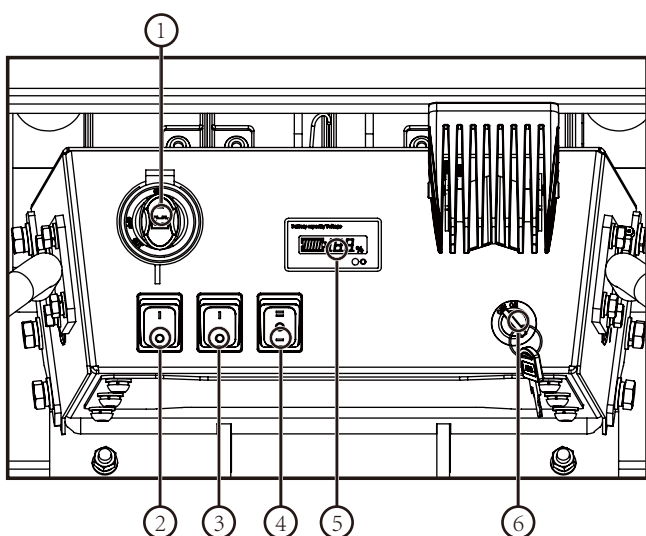

1. Battery Switch: Turn the Button to "ON" /"OFF" position,machine power will be on/off. And 5 electricity indicator will be on, when the button to "ON" position.
2. Front Light Button
3. Light (on the control Panel )Button
- 4.Speed Button: choose speed 1.2.3
- 5.Voltmeter
- 6.Switch Lock:Turn on /off the dumper by turning the keys to on/off position.

## Electrical Wheelbarrow Operation

### PRELIMINARY CHECKS BEFORE DRIVING

#### 1.1 Checklist

To ensure proper operation and maximum service life, it is necessary to carry out some preliminary checks before working session:

- Battery: check battery status with display.
- Tracks: check for tension, looseness ordamage.
- Cleaning: check for any dirt or debris.
- Tightening of parts: check for any loosening and solveit.
- Transmission clutch lever: checkoperation.
- Steering clutch levers: checkoperation.
- Container box: check that it is locked in the lowered position

For all detailed maintenance activities, refer to 'Maintenance'chapter.

#### 1.2 Battery check and recharge



**Notice**

- Battery:Recharge the battery with appropriate charger**
- Avoid that dust or water gets into the charging port**

- 1.Turn on the battery
- 2.Turn on the dumper with keys
- 3.Check the battery percentage with the display

### ENGINE STARTING



**DANGER**

- Start the engine after confirm safety background**
- Make sure the transmission clutch is at stop position before starting the engine, to avoid any accidents.**



**Notice**

- Do not let the handle go back quickly. Accompany the handleslowly, to avoiddamage.**
- Do not pull the starter handle with the engine running as this could damage thestarter.**

1. Turn on the battery(ON position).

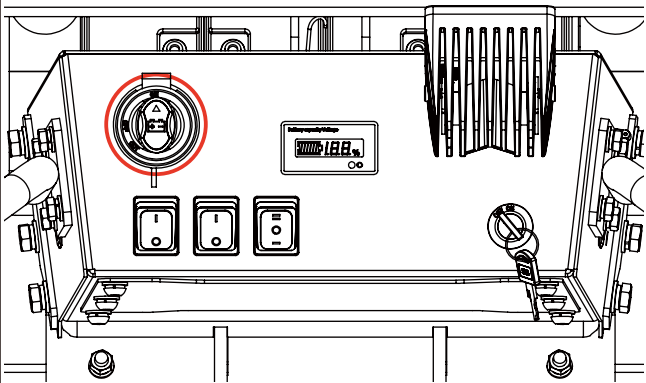

2. Make sure the transmission clutch is at STOP position.

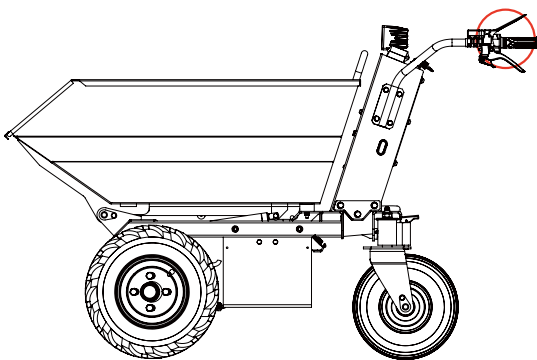

3. Turn on the dumper by turning the keys to on.

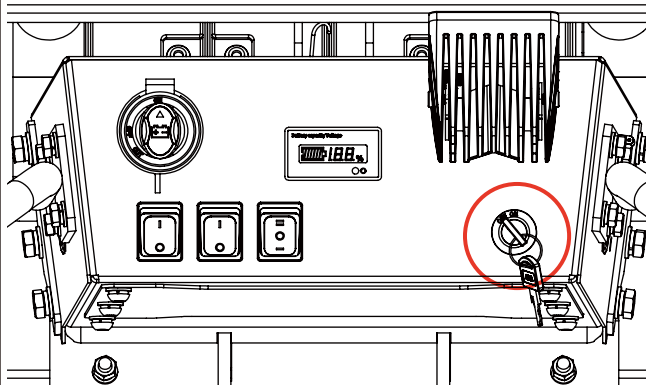

4. Engage the gear ("F" is gear and "R" is reverse gear)

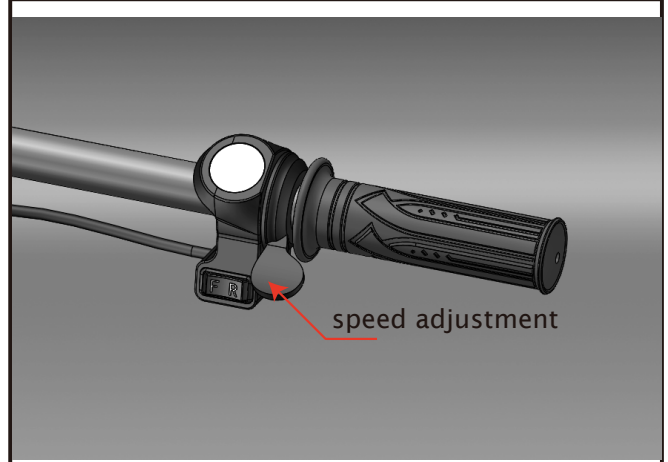

5. Choose the speed (1 2 or 3)

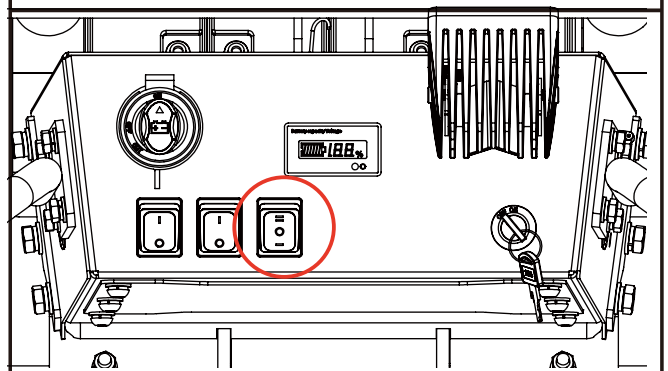

#### DRIVING



**DANGER**

- Before starting work, check the function of the brakes.
- To avoid loss of control on steep descents, proceed to **LOW SPEED**, with the throttle in the 1 position.
- The turn may be abrupt. Make sure the load is well secured to the box. Pay particular attention when steering on slopes.

## 1. Driving

- 1.1. Follow the procedure for starting the engine.
- 1.2. Push the speed button to the 1, 2 or 3 position.
- 1.3. Select the desired gear ("D" for normal gear or "R" for reverse gear).
- 1.4. Press the red accelerator lever to operate the dumper. The machine will move.
- 1.5. Release the red accelerator lever to brake.

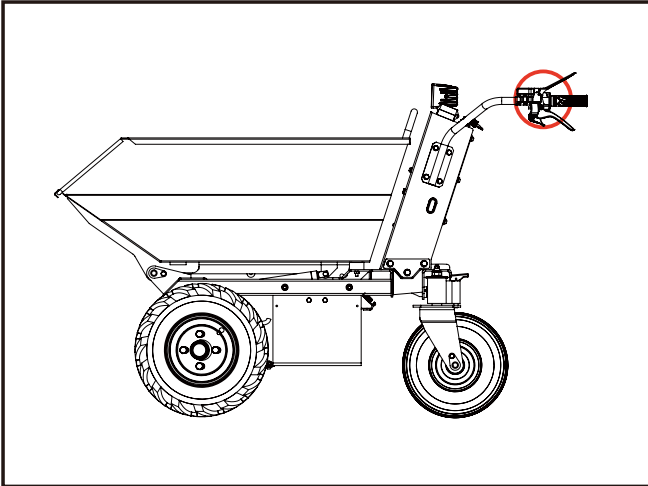

## 2. Load carrying



**DANGER**

*To avoid accidents or overturning:*

- Respect the safety load limits indicated at 'Safety indication' section, chapter 1 and at 'Load limit' section herebelow.
- Do not position the load in such a way as to unbalance the center of gravity of the machine. Pay attention to the height of the load. Pay attention to the load width.
- Be sure that the load does not protrude from the box walls.
- Be sure that the load does not reduce operator's visibility.
- Secure the load with strong ropes or straps, by using the fixing hooks. Do not fasten the ropes to other parts of the machine.
- When carrying a heavy load, pay special attention to the balance of the machine, be sure the load is well distributed and not tilted. If the load is tilted, it may result in serious injury and damages, because the machine may tip over during departure, braking or traveling on bad roads
- Before operating the machine, check that the box is locked (side walls and front wall).
- If you use the truck on a soft or uneven ground, reduce the speed and pay close attention.
- Use the low gear and the throttle in the 1 position on steep descents. Never use reverse gear down hill.
- Be extremely careful during starting, stopping or steering the machine, when working on slopes.

### 2.1 Load limits



**DANGER**

- Respect the load limits and slope limits indicated here below
- Under slope condition:
  - Always drive the machine using first level gear.
  - On unstable ground, reduce speed and proceed with caution
  - Down hill, reduce engine speed and use the engine brake.
  - Be especially careful when moving or stopping the carriage in slope.
  - On steep slopes avoid gear changes and "U" turns.
  - Secure the load with ropes.
  - If stability is not achieved, consider reducing the load
  - As visibility decreases on slopes, consider reducing the height of the load.

### Flat terrain condition

- Max load = 500 Kg
- Max load height \* = 800 mm

\* from bottom surface of the box

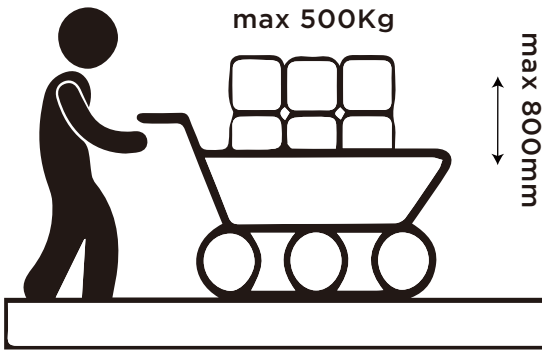

### Slope condition

- Max admissible slope = 15°
- Max load =
  - 200 Kg, for slopes < 10° (17%)
  - 100 Kg, for slopes between 10° and 15° (17% ÷ 26%)
- Max load height (from bottom surface of the box) =
  - 300 mm for descent
  - 500 mm for ascent

\* from bottom surface of the box

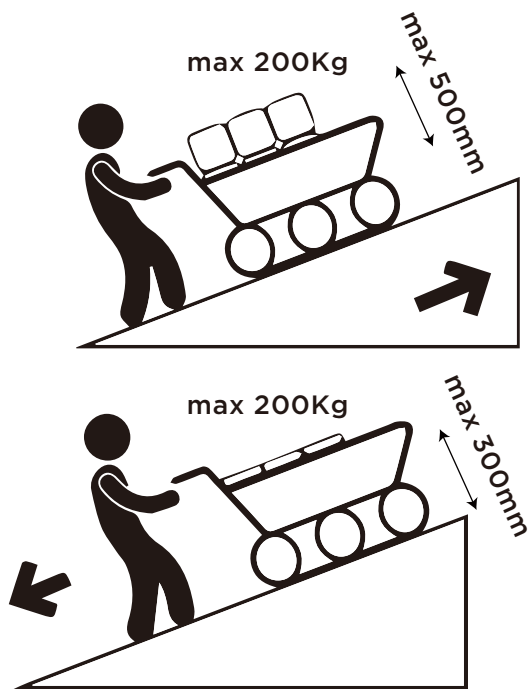

## 2.2 Unloading



**DANGER**

*-Before unloading, stop the machine (see 'Engine switch off' chapter')*

*- Make sure the unloading area is clear of people and other objects*

1. Take the handle and pull the cable
2. Lift the lever and tilt the box
3. After unloading is complete, return the box to its original position, push hard on the lever and lock it in lowered position.

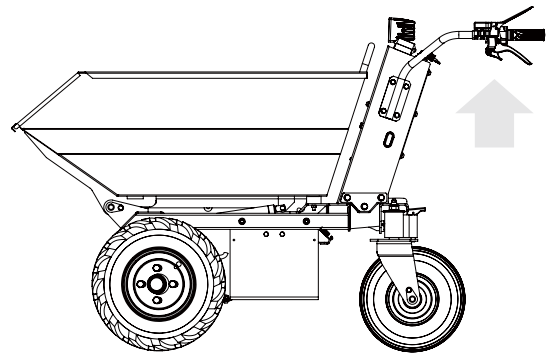

### MACHINE SWITCH OFF



**DANGER**

*-Avoid abrupt stop: it may cause machine / load overturn*

*-Stop the machine in a flat area, without any potential dangers*

*-Forbid to park in beveled level, if necessary, should fasten the wheels*

### 1. Emergency switch off

1. Release the red throttle lever to brake and stop the dumper. The machine will stop.
2. Turn the battery switch to OFF position.

### 2. Normal switch off

1. Release the red throttle lever to brake and stop the dumper.
2. Turn the key on the ignition and turn it to OFF
3. Turn the battery switch to OFF position.

## MAINTENANCE

Periodic maintenance and adjustments are required to maintain the machine in good condition. Carry out inspection and maintenance according to the maintenance schedule here below.

Do not start maintenance operations in case of poor visibility.



**DANGER**

- *Stop the machine before proceeding with any operation of maintenance.*
- *Before maintenance, wait for the hot parts to cool down.*



**WARNING**

- *Maintenance operator must use personal protective equipment, such as gloves, shoes, glasses.*



**NOTICE**

- *Use recommended products.*
- *Use original spare parts or their equivalent. The use of non equivalent quality parts could damage the machine.*

### Lubricating the wheels

We recommend you to lubricate the wheels every 100 hours of use. This is to ensure smooth operation.

### Tires

Check to make sure the lug nuts on the tires are secure. Loose lug nuts may cause the tire to come loose and result in the loss of control.

### Hardware

Periodically check all fasteners/hardwares for proper tightness. Retighten any loose hardwares.

### Wire connections

Periodically check all wire connections.

### Brake system

Usually check the carbon brush of the motor, need to change new one if severe wear.

### Charger

Regularly examine the charger for damage to the cord, plug, housing or other parts that may result in the risk of fire, electric shock or injury. In the event of any damage, do not use the charger until the damage has been properly repaired.

## Battery

Regularly examine the batteries, always keep them clean and dry. It is recommended to fully charge your batteries installed in your machine before each use. Always charge the batteries in the upright position. For best results, charge the batteries while installed in your machine. When in storage keep the battery box and/or machine in an upright position with the machine drive wheels and both support legs flat on level ground.

## STORAGE

If the machine will not be used for a period longer than 30 days, pay attention to below aspects for proper storage.

1. The batteries should be fully charged before storage, and regularly charge them.
2. Keep the batteries clean and dry, do not store the whole machine in wet environment. Batteries also age during storage.
3. Protect the batteries from overheating and flames: danger of explosion.
4. Use clean cloths to clean off the outside of the machine and to keep the air vents free of obstructions.
5. Store your unit on flat ground in a clean, dry building that has good ventilation.
6. During storage, do not leave the wheelbarrow exposed to direct sunlight.
7. Before storing the batteries, separate them from any electrical circuit and place them preferably in a cool and dry place.
8. During storage, disconnect the batteries from the motor unit by separating the connectors and eventually the cables from the terminals.

## DISPOSAL WARNINGS

Appliances, accessories, and packaging should be sent for ecological reuse. The exhausted batteries must be recycled according to directive 2006/66/EC. Do not throw away the batteries consumed in household waste, in fire or water. Do not open the batteries and return them using the special collection facilities. Do not dispose of together with municipal solid waste but collect them separately. The substances and electrical components contained in this appliance, if abandoned or used improperly, they could be harmful to the environment. The symbol of the "garbage can on wheels crossed out and with a black bar depicted under the bin", indicates that this appliance is was placed on the market after 08/13/05 and is subject to separate collection. Any abuse will come prosecuted by law.

# TROUBLE SHOOTING

Problem	Possible Cause	Solution
<p>Machine does not run.</p> <p>Machine was running but suddenly stopped.</p> <p>Short run time(less than 1-3 hours per charge.)</p> <p>Machine runs sluggishly.</p> <p>Battery lights do no illuminate.</p>	Undercharged battery.	Charge the battery.A new battery should have been charged for at least 12 hours before using the machine for the first time.After first time use,recharge the battery until the green charge light illuminates.
		Check all connectors.Make sure the charger connector is plugged into the battery box,and that the charger is plugged into to outlet.
		Make sure power flow to the wall outlet is "ON".
	Charger is not working.	There is no sure way to tell if your charger is working unless you have a volt meter.If you suspect there is a problem with your charger,contact the customer service.
	Loose wire or loose connectors.	Check all wires and connectors.Make sure the motor harness connector is plugged into the battery,and that there are no loose wires.
	Dead battery.	Charge the battery as showed in the Owner's manual.
	Motor damage.	
	Overcharged battery.	Do not charge the battery longer than 30 hours.If you suspect damage due to overcharging,contact customer service.
<p>Sometimes the machine doesn't run but other times it does.</p>	Loose wire or connector.	Check all wire connections to make sure they are tight.
	Motor or electrical damage.	Contact customer service for diagnosis and/or repair.
<p>Battery makes a sizzling or gurgling noise when charging.</p>	<p>It is normal for the batteries to make noise or swell slightly while charging and is not reason for concern.</p>	No Action required.
		If your battery does not make noise or swell slightly during charging,it does not mean that it is not accepting the charge.
<p>One or more tires are flat.</p>	Tire has lost air.	Inflate the tire with proper quantity air.
	Tire puncture.	Patch or replace damaged inner Tube.
	Leaky tire air valve.	Replace or tighten tire air valve.
<p>Machine feels loose or less solid then initial assembly.</p>	Hardware has become loose.	Retighten all hardware using tools.

