

LITTLE BEAVER

Brush cutter/Grass trimmer



Instructions

DUEXBC4335S

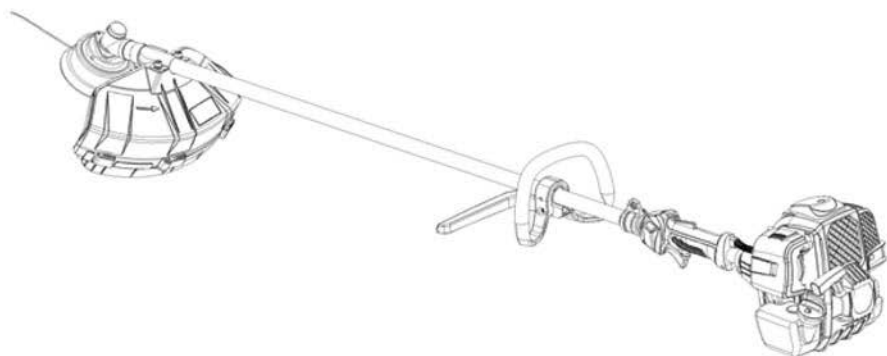

WARNING

- Before using our products, please read this manual carefully to understand the proper use of your unit.
- Keep this instructions handy.

CONTENS

HOW TO READ THE MANUAL

Certain paragraphs in the manual contain particularly significant information and are marked with various levels of highlighting with the following meaning:

NOTE or IMPORTANT

These give details or further information on what has already been said, and aim to prevent damage to the machine or cause other damage.

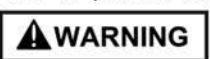
 **WARNING** Non-observance will result in the risk of serious injury or death to oneself or others.

Contents	1
Getting to know the machine	1
1. Information of symbols	2
2. Identification	3
Safety regulations	5
1. Important	5
2. Personal protective equipment	6
3. Machine's safety equipment	6
4. Cutting equipment	9
Operating instructions	11
1. Prepare the machine	11
2. Fuel handling	13
3. Using the machine	15
4. General working instructions	18
5. Routine maintenance	21
6. Maintenance timescale	23
7. Trouble shooting.....	24
Technical information	25

GETTING TO KNOW MACHINE

1. INFORMATION OF SYMBOLS



WARNING! A brush cutter or trimmer can be dangerous if used incorrectly or carelessly, and can cause serious or fatal injury to the operator or others. It is extremely important that you read and understand the contents of this owner's manual.



Please read the operator's manual carefully and make sure you understand the instructions before using the machine.



Always wear:

- A protective helmet where there is a risk of falling object
- Approved hearing protection and eye protection



Always wear approved protective gloves.



Wear sturdy, non-slip boots.



Max. speed of output shaft, min^{-1}

$\leq 7350 \text{ n/min}$



Machines fitted with saw blades or grass blades can be thrown violently to the side when the blade comes into contact with a fixed object. This is called blade thrust. The blade is capable of amputating an arm or leg. Always keep people and animals at least 15 metres from the machine.



Watch out for thrown objects and ricochets.



Do not use saw blades

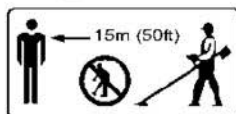

The operator of the machine must ensure, while working, that no persons or animals come closer than 15 metres.



Guarantee A-weighted emission noise power level



Fuel tank

2. IDENTIFICATION

DUEXBC4335S

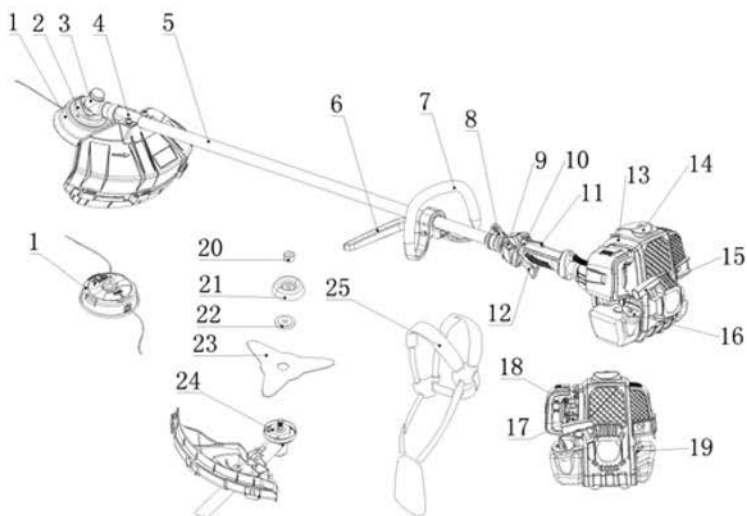

1 Trimmer head
2 Top protecting cap
3 Gear box
4 Cutting attachment guard
5 Drive shaft tube

6 Barrier
7 Front handle
8 Suspension ring

9 Engine switch
10 Rear handle
11 Throttle trigger lock-out
12 Throttle trigger guard
13 Engine
14 Spark plug cover
15 Starter handle
16 Fuel tank cap

17 Primer bulb
18 Start-aid knob
19 Oil tank cap
20 Locking nut
21 Bottom Protecting cap
22 Bottom clamping plate
23 Metal blade
24 Top clamping plate
25 Harness

DUEXBC4335S

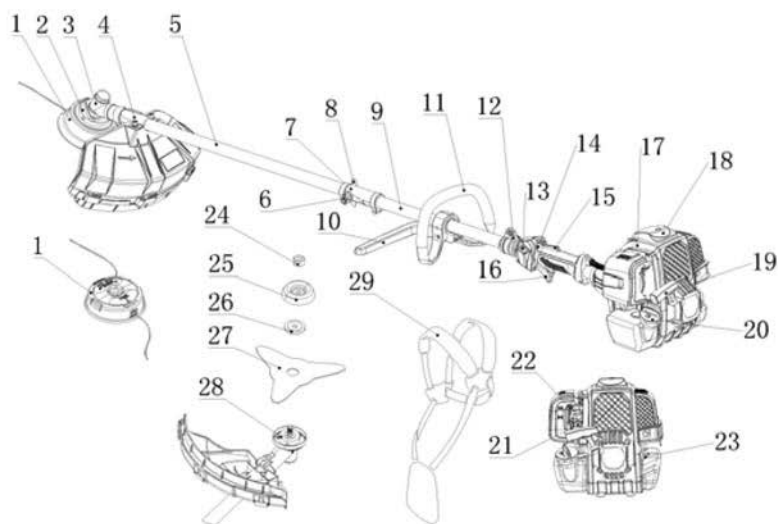

- 1 Trimmer head
- 2 Top protecting cap
- 3 Gear box
- 4 Cutting attachment guard
- 5 Front tube
- 6 Locking pin
- 7 Connector
- 8 Locking knob
- 9 Rear tube
- 10 Barrier

- 11 Front handle
- 12 Suspension ring
- 13 Engine switch
- 14 Rear handle
- 15 lock-out Throttle trigger
- 16 Throttle trigger
- 17 Engine
- 18 Spark plug cover
- 19 Starter handle
- 20 Fuel tank cap

- 21 Primer bulb
- 22 Start-aid knob
- 23 oil tank cap
- 24 Locking nut
- 25 Bottom Protecting cap
- 26 Bottom clamping plate
- 27 Metal blade
- 28 Top clamping plate
- 29 Harness

SAFETY REGULATIONS

1) IMPORTANT

The machine is only designed for trimming grass and cutting bushes.

The only accessories you can operate with this engine unit are the cutting attachments we recommend in the chapter on Technical data.

Never use the machine if you are tired, if you are ill, if you have drunk alcohol, or if you are taking medication that could affect your vision, your judgement or your coordination.

Wear personal protective equipment. See instructions under the heading "Personal protective equipment".

Never use a machine that has been modified in any way from its original specification.

Never use a machine that is faulty. Carry out the checks, maintenance and service instructions described in this manual. Some maintenance and service measures must be carried out by trained and qualified specialists. See instructions under the heading "Routine maintenance".

All covers, guards and handles must be fitted before starting. Ensure that the spark plug cap and ignition lead are undamaged to avoid the risk of electric shock.

The machine operator must ensure that no people or animals come closer than 15 metres while working.

Never allow children or people unfamiliar with these instructions to use the machine.

Local laws can restrict the minimum age of the operator.

Secure the machine during transport to prevent loss of fuel, damage or injury;

Cleaning and maintenance before storage, including the use of guards on cutting attachments with metal blades;

Use of a transport cover for metal blades during transport and storage;

Alert! national regulations (Occupational Safety and Health, environment) may be present, which can restrict the use of the machine;

Daily inspect the machine before use and after dropping or other impacts to identify any significant defects;

Keep firm footing and balance during operation, use the harness provided;

During a working day, you shall take frequent and adequate breaks to prevent damage from vibration and damage to the ears.

During a working day, you shall take frequent and adequate breaks to prevent damage from vibration and damage to the ear, and change working positions frequently.



This machine produces an electromagnetic field during operation. This field may under some circumstances interfere with active or passive medical implants. To reduce the risk of serious or fatal injury, we recommend persons with medical implants to consult their physician and the medical implant manufacturer before operating this machine.

The exhaust gases emitted from engine contain dangerous carbon monoxide.

Running an engine in a confined or badly ventilated area can result in death due to asphyxiation or carbon monoxide poisoning.

Prolonged exposure to vibrations can cause injuries and neurovascular disorders

(also called “Raynaud’s syndrome” or “white hand”), especially to people suffering from circulation disorders. The symptoms can regard the hands, wrists and fingers and are shown through loss of sensitivity, torpor, itching, pain and discolouring of or structural changes to the skin. These effects can be worsened by low ambient temperatures and/or by gripping the handgrips excessively tightly. If the symptoms occur, the length of time the machine is used must be reduced and a doctor consulted.

2) PERSONAL PROTECTIVE EQUIPMENT

IMPORTANT You must use approved personal protective equipment whenever you use the machine. Personal protective equipment cannot eliminate the risk of injury but it will reduce the degree of injury if an accident does happen. Ask your dealer for help in choosing the right equipment.

Listen out for warning signals or shouts when you are wearing hearing protection.

Always remove your hearing protection as soon as the engine stops.

HELMET A protective helmet where there is a risk of falling objects.

HEARING AND EYE PROTECTION Wear hearing protection that provides adequate noise reduction. Always wear approved eye protection.

GLOVES Gloves should be worn when necessary, e.g., when fitting cutting attachments.

BOOTS Wear boots with steel toe-caps and non-slip sole.

CLOTHING Wear clothes made of a strong fabric and avoid loose clothing that can catch on twigs and branches. Always wear heavy, long pants. Do not wear jewellery, shorts sandals or go barefoot. Secure hair so it is above shoulder level.

FIRST AID KIT Always have a first aid kit nearby.

3) MACHINE’S SAFETY EQUIPMENT

WARNING! Never use a machine with faulty safety equipment. The machine’s safety equipment must be checked and maintained as described in this section. If your machine fails any of these checks contact your service agent to get it repaired.

3.1 Throttle lockout

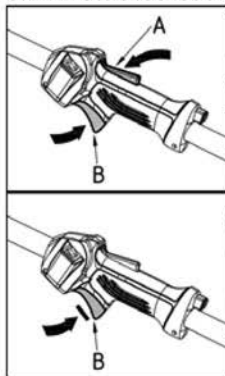

The throttle lockout is designed to prevent accidental operation of the throttle control. When you press the lock-out (A) (i.e. when you grasp the handle) it releases the throttle trigger (B). When you release the handle the throttle control and the throttle lockout both move back to their original positions. This movement is controlled by two independent return springs. This arrangement means that the throttle control is automatically locked at the idle setting.

Make sure the throttle control is locked at the idle setting when the throttle lockout is released.

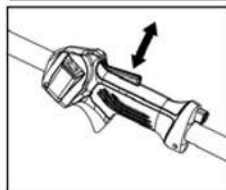

Press the throttle lockout and make sure it returns to its original position when you release it.

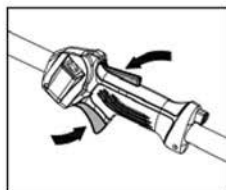

Check that the throttle control and throttle lockout move freely and that the return springs work properly. See instructions under the heading Start. Start the machine and apply full throttle. Release the throttle and check that the cutting attachment stops and remains at a standstill. If the cutting attachment rotates with the throttle in the idle position then the carburettor idle setting must be checked. (See instructions under the heading Maintenance)

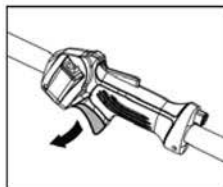

3.2 Engine switch

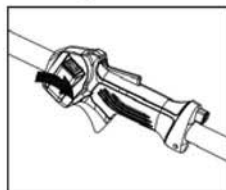

Press down the "O" side of the engine switch to stop the engine. Start the engine and make sure the engine stops when you move the engine switch to the stop setting.

3.3 Cutting attachment guard

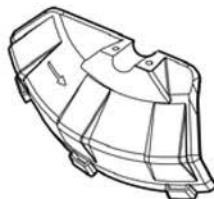

This guard is intended to prevent loose objects from being thrown towards the operator. The guard also protects the operator from accidental contact with the cutting attachment. Check that the guard is undamaged and not cracked. Replace the guard if it has been exposed to impact or is cracked. Always use the recommended guard for the cutting attachment you are using. See chapter on Technical data.

WARNING

Never use a cutting attachment without an approved guard. See the chapter on Technical data. If an incorrect or faulty guard is fitted this can cause serious personal injury.

3.4 Vibration damping system

Your machine is equipped with a vibration damping system that is designed to minimize vibration and make operation easier.

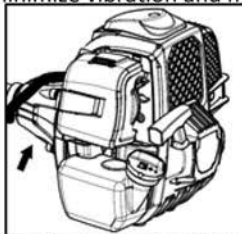

Using incorrectly wound cord or a blunt or incorrect cutting attachment (wrong type or incorrectly filed, see instructions under the heading Filing the blade) increases the level of vibration.

The machine's vibration damping system reduces the transfer of vibration between the engine unit/cutting equipment and the machine's handle unit.

Regularly check the vibration damping units for cracks or deformation.

Check that the vibration damping element is undamaged and securely attached.

3.5 Quick release

There is an easily accessible, quick release fitted near the suspension ring as a safety precaution in case the engine catches fire, or in any other situation that requires you to free yourself from the machine.

3.6 Muffler



The muffler is designed to keep noise levels to a minimum and to direct exhaust fumes away from the user.

Never use a machine that has a faulty muffler.

Regularly check that the muffler is securely attached to the machine.



The inside of the muffler contain chemicals that may be carcinogenic. Avoid contact

with these elements in the event of a damaged muffler.

Bear in mind that: The exhaust fumes from the engine are hot and may contain sparks which can start a fire. Never start the machine indoors or near combustible material!

3.7 Locking nut

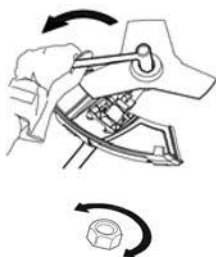

A locking nut is used to secure some types of cutting attachment. When fitting, tighten the nut in the opposite direction to the direction of rotation of the cutting attachment. To remove it, undo the nut in the same direction as the cutting attachment rotates. (CAUTION! The nut has a left-hand thread.) Tighten the nut using the socket spanner.

The nylon lining inside the locking nut must not be so worn that you can turn it by hand. The lining should offer a resistance of at least 1.5 Nm. The nut should be replaced after it has been put on approx. 20 times.

4) CUTTING ATTACHMENT

This section describes how to choose and maintain your cutting equipment in order to:

- Reduce the risk of blade thrust.
- Obtain maximum cutting performance.
- Extend the life of cutting equipment.

IMPORTANT Only use cutting attachments with the guards we recommend! Refer to the instructions for the cutting attachment to check the correct way to load the cord and the correct cord diameter.

Keep the teeth of the blade correctly sharpened! Follow our recommendations. Also refer to the instructions on the blade packaging.



WARNING Always stop the engine before doing any work on the cutting attachment. This continues to rotate even after the throttle has been released. Ensure that the cutting attachment has stopped completely and disconnect the HT lead from the spark plug before you start to work on it. Using an incorrect cutting attachment or an incorrectly sharpened blade increases the risk of blade thrust.

4.1 Cutting attachment

Grass blades and grass cutters are intended for cutting coarse grass.



A trimmer head is intended for trimming grass.

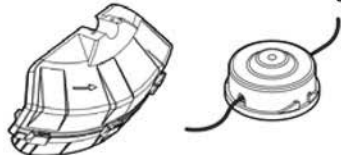

General rules

Only use cutting attachments with the guards we recommend! Never to use other cutting attachment like metal multi-piece pivoting chains and flail blades which are not recommended, if used it's likely to lead to mechanical hazards to operator.

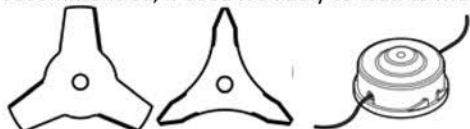

Keep the teeth of the blade correctly sharpened! Follow our instructions and use the recommended file gauge. An incorrectly sharpened or damaged blade increases the risk of accidents.

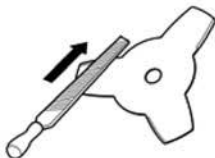

Check the cutting attachment for damage or cracks. A damaged cutting attachment should always be replaced.

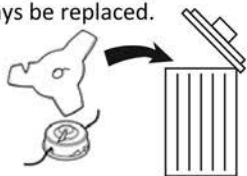

4.2 Sharpening grass cutters and grass blades

Sharpen blades and cutters using a single-cut flat file.

Sharpen all edges equally to maintain the balance of the blade.

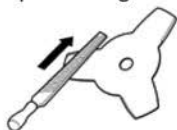

WARNING

Always discard a blade that is bent, twisted, cracked, broken or damaged in any other way. Never attempt to straighten a twisted blade so that it can be reused. Only use original blades of the specified type.

4.3 Trimmer head

IMPORTANT Always ensure the trimmer cord is wound tightly and evenly around the drum, otherwise the machine will generate harmful vibration.

Only use the recommended trimmer heads and trimmer cords. These have been tested by the manufacturer to suit a particular engine size. This is especially important when a fully automatic trimmer head is used. Only use the recommended cutting attachment. See the chapter on Technical data.

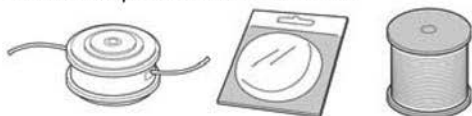

Smaller machines generally require small trimmer heads and vice versa. This is because when clearing using a cord the engine must throw out the cord radially from the trimmer head and overcome the resistance of the grass being cleared.

The length of the cord is also important. A longer cord requires greater engine power than a shorter cord of the same diameter.

Make sure that the cutter on the trimmer guard is intact. This is used to cut the cord to the correct length.

To increase the life of the cord it can be soaked in water for a couple of days. This will make the line tougher so that it lasts longer.

OPERATING INSTRUCTIONS

1) PREPARE THE MACHINE

1.1 Assembling the front handle

Align the position hole (B1) on the clamp ring (B) with one position hole (A1) of three on the tube (A), and then fit the barrier (C) on the clamp ring, and while aligning hole on clamp ring and the groove on spacer block. (Fig. 1)

Align the position pin (D1) on the front handle (D) with the position hole (B1) on the clamp ring (B). (Fig. 2)

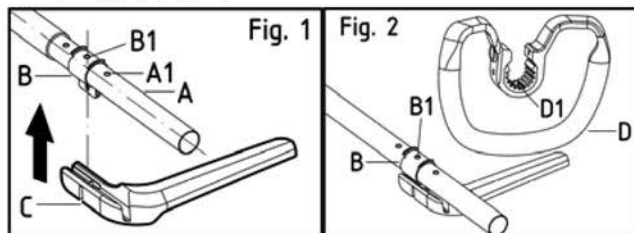

Push down the front handle (D) until the hole on the front handle aligned to the groove on the spacer block. (Fig. 3)

Insert the locking screw into the front handle, and then turn it clockwise to tighten the front handle. (Fig. 4)

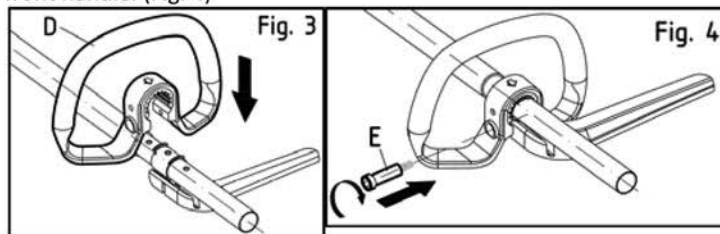

1.2 CONNECTING THE TUBE (FOR DUEXBC4335S)

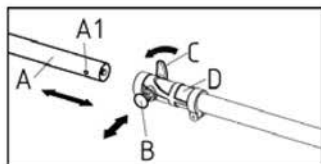

Align the hole (A1) on the front tube (A) and the lock pin (B). Then, Pull out the Lock pin, and while inserting the front tube in the connector (D) to the end. After loosened the lock pin, it will return to its original position automatically, and insert into the hole on the front tube.

Make sure the front tube can't be rotated after the lock pin came back to its original position. Turn the lock knob (C) clockwise to tighten the front tube securely.

1.3 Fitting blades and trimmer heads



WARNING When fitting the cutting attachment it is extremely important that the raised section on the top clamping plate/support flange engages correctly in the centre hole of the cutting attachment. If the cutting attachment is fitted incorrectly it can result in serious and/or fatal personal injury.

Never use a cutting attachment without an approved guard. If an incorrect or faulty guard is fitted this can cause serious personal injury. Wear gloves to avoid sharp edges of blade or other components to injury the operator while complete assembly. If a grass blade is to be used the machine must be equipped with the correct handlebar, blade guard and harness.

1.4 Fitting the guard extension



The guard extension shall always be fitted when using the trimmer head and combination guard. The guard extension shall always be removed when using the grass blade and combination guard.

Hook the blade guard/combination guard onto the fitting on the shaft and secure with three bolts.



Enter the guard extension guide in the slot of the combination guard. Then click the guard extension into position on the guard with some claws.



The guard extension is removed easily using a screwdriver, see illustration.

1.5 Fitting a blade guard, grass blade and grass cutter



Hook the blade guard/combination guard onto the fitting on the shaft and secure with three bolts. Use the recommended blade guard. See the Technical data section. **CAUTION!** Ensure that the guard extension is removed.

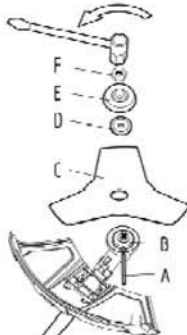

Fit the top clamping plate (B) on the output shaft.

Turn the blade shaft until one of the holes in the top clamping plate aligns with the corresponding hole in the top protecting cap.

Insert the locking pin (A) in the hole to lock the shaft.

Place the blade (C), bottom clamping plate (D) and bottom protecting cap (E) on the output shaft.

Fit the nut (F). The nut must be tightened to a torque of 35-50 Nm (3.5-5 kpm). Use the socket spanner in the tool kit. Hold the shaft of the spanner as close to the blade guard as possible. To tighten the nut, turn the spanner in the opposite direction to the direction of rotation (Caution! left-hand thread).

Pull out the locking pin after all installation process has been finished.

1.6 Fitting the trimmer guard and trimmer head

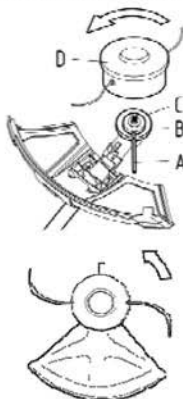

- Fit the correct trimmer guard for use with the trimmer head.
CAUTION! Ensure that the guard extension is fitted.
 Hook the trimmer guard/combination guard onto the fitting on the shaft and secure with three bolts.
 Fit the top clamping plate (B) on the output shaft.
 Turn the blade shaft until one of the holes in the top clamping plate aligns with the corresponding hole in the top protecting cap (C).
 Insert the locking pin (A) in the hole to lock the shaft.
 Screw on the trimmer head (D) in the opposite direction to the direction of rotation.
 To dismantle, follow the instructions in the reverse order.

1.7 Adjusting the harness and brush cutter



WARNING

When using a brush cutter it must always be hooked securely to the harness. Otherwise you will be unable to control the brush cutter safely and this can result in injury to yourself or others. Never use a harness with a defective quick release.



At the front is an easily accessible, quick release. Use this if the engine catches fire or in any other emergency situation that requires you to free yourself from the machine and harness. A well-adjusted harness and machine makes work much easier. Adjust the harness for the best working position. Tension the side straps so that the weight is evenly distributed across both shoulders.



Adjust the shoulder strap so that the cutting attachment is parallel to the ground.



Let the cutting attachment rest lightly on the ground. Adjust the position of the suspension ring to balance the brush cutter correctly.

2) FUEL HANDLING

2.1 Fuel safety

Never start the machine:

- If you have spilt fuel on it. Wipe off the spillage and allow remaining fuel to evaporate.
- If you have spilt fuel on yourself or your clothes, change your clothes. Wash any part of your body that has come in contact with fuel. Use soap and water.
- If the machine is leaking fuel. Check regularly for leaks from the fuel cap and fuel

lines.

2.2 Transport and storage

- Store and transport the machine and fuel so that there is no risk of any leakage or fumes coming into contact with sparks or naked flames, for example, from electrical machinery, electric motors, electrical relays/ switches or boilers.
- When storing and transporting fuel always use approved containers intended for this purpose.
- When storing the machine for long periods the fuel tank must be emptied. Contact your local petrol station to find out where to dispose of excess fuel.
- Ensure the machine is cleaned and that a complete service is carried out before long-term storage.
- The transport guard must always be fitted to the cutting attachment when the machine is being transported or in storage.
- Secure the machine during transport.
- In order to prevent unintentional starting of the engine, the spark plug cap must always be removed during long-term storage, if the machine is not under close supervision and when performing all service measures.

▲ WARNING

Take care when handling fuel. Bear in mind the risk of fire, explosion and inhaling fumes.

2.3 Fuel

The machine is equipped with a four-stroke engine and must always be run using petrol without other fuel or oil.

▲ WARNING

Fuel and fuel fumes are highly inflammable and can cause serious injury when inhaled or allowed to come in contact with the skin. For this reason observe caution when handling fuel and make sure there is adequate ventilation.

Always use a quality petrol at least 90 octane (RON).

Use low-emission petrol, also known as alkylate petrol, if it is available.

The lowest octane recommended is 90 (RON). If you run the engine on a lower octane grade than 90 so-called knocking can occur. This gives rise to a high engine temperature, which can result in serious engine damage.

When working at continuous high revs a higher octane rating is recommended.

2.5 Lubricant

Always use a quality lubricant oil, use model 20W-40 as lubricant, while air temperature is considered.

Keep the engine level, pour oil into oil tank until can not overflow.

Change oil until the engine run 8-10 hours, used oil



can result in serious engine damage.

2. Fuelling

Taking the following precautions, will lessen the risk of fire:

Do not smoke or place hot objects near fuel.

Always shut off the engine before refuelling.

Always stop the engine and let it cool for a few minutes before refuelling.

When refuelling, open the fuel cap slowly so that any excess pressure is released gently.

Tighten the fuel cap carefully after refuelling.

Always move the machine away from the refuelling area before starting.

- Always use a fuel container with an anti-spill valve.
- Clean the area around the fuel cap. Contamination in the tank can cause operating problems.

3) USING THE MACHINE

3.1 Check and starting

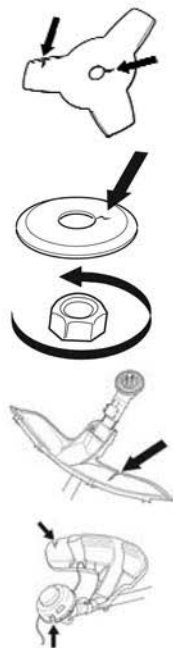

- Never use the machine without a guard nor with a defective guard.
- All covers must be correctly fitted and undamaged before you start the machine.
- Check the blade to ensure that no cracks have formed at the bottom of the teeth or by the centre hole. The most common reason why cracks are formed is that sharp corners have been formed at the bottom of the teeth while sharpening or that the blade has been used with dull teeth. Discard a blade if cracks are found.
- Check that the support flange is not cracked due to fatigue or due to being tightened too much. Discard the support flange if it is cracked.
- Ensure the locking nut has not lost its captive force. The nut lock should have a locking force of at least 1.5 Nm. The tightening torque of the locking nut should be 35-50 Nm.
- Check that the blade guard is not damaged or cracked. Replace the blade guard if it is exposed to impact or is cracked.
- Check that the trimmer head and trimmer guard are not damaged or cracked. Replace the trimmer head or trimmer guard if they have been exposed to impact or are cracked.

3.2 Starting and stopping

The complete clutch cover and shaft must be fitted before the machine is started, otherwise the clutch can come loose and cause personal injury.

Always move the machine away from the refuelling area before starting. Place the

machine on a flat surface. Ensure the cutting attachment cannot come into contact with any object.

Make sure no unauthorised persons are in the working area, otherwise there is a risk of serious personal injury. The safety distance is 15 metres.

3.2.1 Cold starting: A “cold” start of the engine means starting it after at least 5 minutes from when it was switched off or after refuelling.

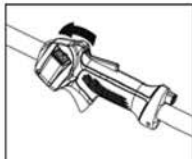

a). **Starting:** Ignition: Press down the “I” side of the engine switch.

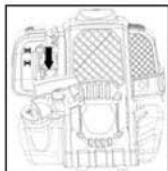

b). **Start aid:** turn the start-aid knob clockwise to the “I” position.



c). **Primer bulb:** Press the primer bulb repeatedly until fuel begins to fill the bulb. The bulb need not be completely filled.



WARNING

The start-aid knob will automatically return to RUN position by pressing the throttle trigger again.



d). Hold the body of the machine on the ground using your left hand (CAUTION! Not with your foot!). Grip the starter handle, quickly and powerfully pull out the cord with your right hand until the engine starts. **Never twist the starter cord around your hand.**

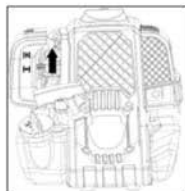

e). Set the start-aid knob in the choke “I” position, allow the engine to warm up with the throttle pulled slightly.

Do not pull the starter cord all the way out and do not let go of the starter handle when the cord is fully extended. This can damage the machine.



Do not put any part of your body in marked area. Contact can result in burns to the skin, or electrical shock if the spark plug cap has been damaged. Always use gloves. Do not use a machine with damaged spark plug cap.

IMPORTANT If the starter rope is pulled repeatedly with the choke on, it may flood the engine and make starting difficult.

If you happen to flood the engine, repeat the hot start procedure a few times to eliminate any excess fuel.

3.2.2 Hot starting

To hot start the engine immediately after it has stopped, follow steps a – c – d of the above procedure, making sure the primer bulb is activated 2-3 times only.

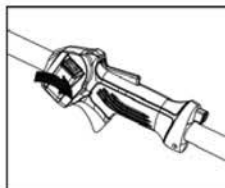

3.2.3 Stopping:

Stop the engine by switching off the ignition.

4) GENERAL WORKING INSTRUCTIONS

IMPORTANT! This section describes the basic safety precautions for working with brush cutters and trimmers.

If you encounter a situation where you are uncertain how to proceed you should ask an expert. Contact your dealer or your service workshop.

Avoid all usage which you consider to be beyond your capability.

You must understand the difference between forestry clearing, grass clearing and grass trimming before use.

4.1 Basic safety rules



Look around you:

- To ensure that people, animals or other things cannot affect your control of the machine.
- To ensure that people, animals, etc., do not come into contact with the cutting attachment or loose objects that are thrown out by the cutting attachment.
- Do not use the machine unless you are able to call for help in the event of an accident.

Inspect the working area. Remove all loose objects, such as stones, broken glass, nails, steel wire, string, etc. that could be thrown out or become wrapped around the cutting attachment.

Do not use the machine in bad weather, such as dense fog, heavy rain, strong wind, intense cold, etc. Working in bad weather is tiring and often brings added risks, such as icy ground, unpredictable felling direction, etc.

Make sure you can move and stand safely. Check the area around you for possible obstacles (roots, rocks, branches, ditches, etc.) in case you have to move suddenly.

Take great care when working on sloping ground.

Keep a good balance and a firm foothold.

Always hold the machine with both hands. Hold the machine on the right side of your body.



Keep the cutting attachment below waist level.

Switch off the engine before moving to another area. Fit the transport guard before carrying or transporting the equipment any distance.

Never put the machine down with the engine running unless you have it in clear sight.



Neither the operator of the machine nor anyone else may

attempt to remove the cut material while the engine is running or the cutting equipment is rotating, as this can result in serious injury.

Stop the engine and cutting equipment before you remove material that has wound around the blade shaft as otherwise there is a risk of injury. The bevel gear can get hot during use and may remain so for a while afterwards. You could get burnt if you touch it.

Watch out for thrown objects. Always wear approved eye protection. Never lean over the cutting attachment guard. Stones, rubbish, etc. can be thrown up into the eyes causing blindness or serious injury.

Keep unauthorised persons at a distance. Children, animals, onlookers and helpers should be kept outside the safety zone of 15 m. Stop the machine immediately if anyone approaches. Never swing the machine around without first checking behind you to make sure no-one is within the safety zone.

4.2 Basic working techniques

Always slow the engine to idle speed after each working operation. Long periods at full throttle without any load on the engine can lead to serious engine damage.



Sometimes branches or grass get caught between the guard and cutting attachment. Always stop the engine before

cleaning.

Machines fitted with grass blades can be thrown violently to the side when the blade comes into contact with a fixed object. This is called blade thrust. A blade thrust can be violent enough to cause the machine and/or operator to be propelled in any

direction, and possibly lose control of the machine. Blade thrust can occur without warning if the machine snags, stalls or binds. Blade thrust is more likely to occur in areas where it is difficult to see the material being cut.

Avoid cutting with the area of the blade between the 12 o'clock and 3 o'clock positions. Because of the speed of rotation of the blade, blade thrust can occur if you attempt to cut thick stems with this area of the blade.

4.3 Grass clearing using a grass blade

Grass blades and grass cutters must not be used on woody stems.

A grass blade is used for all types of tall or coarse grass.

The grass is cut down with a sideways, swinging movement, where the movement from right-to-left is the clearing stroke and the movement from left-to-right is the return stroke. Let the left-hand side of the blade (between 8 and 12 o'clock) do the cutting.



If the blade is angled to the left when clearing grass, the grass will collect in a line, which makes it easier to collect, e.g. by raking.

Try to work rhythmically. Stand firmly with your feet apart. Move forward after the return stroke and stand firmly again.

Let the support cup rest lightly against the ground. It is used to protect the blade from hitting the ground.

Reduce the risk of material wrapping around the blade by following these instructions:

- Always work at full throttle.
- Avoid the previously cut material during the return stroke.

Stop the engine, unclip the harness and place the machine on the ground before you start to collect the cut material.

4.4 Grass trimming with a trimmer head

4.4.1 Trimming



Hold the trimmer head just above the ground at an angle. It is the end of the cord that does the work. Let the cord work at its own pace. Never press the cord into the area to be cut.

The cord can easily remove grass and weeds up against walls, fences, trees and borders, however it can also damage sensitive bark on trees and bushes, and damage fence posts.

Reduce the risk of damaging plants by shortening the cord to 10-12 cm and reducing the engine speed.

4.4.2 Clearing

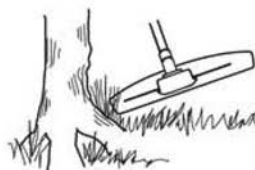

The clearing technique removes all unwanted vegetation. Keep the trimmer head just above the ground and tilt it. Let the end of the cord strike the ground around trees, posts, statues and the like. **CAUTION!** This technique increases the wear on the cord.

The cord wears quicker and must be fed forward more often when working against stones, brick, concrete, metal fences, etc., than when coming into contact with trees and wooden fences.

When trimming and clearing you should use less than full throttle so that the cord lasts longer and to reduce the wear on the trimmer head.

4.4.3 Cutting

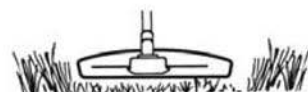

The trimmer is ideal for cutting grass that is difficult to reach using a normal lawn mower. Keep the cord parallel to the ground when cutting. Avoid pressing the trimmer head against the ground as this can ruin the lawn and damage the tool.

Do not allow the trimmer head to constantly come into contact with the ground during normal cutting. Constant contact of this type can cause damage and wear to the trimmer head.

4.4.4 Sweeping

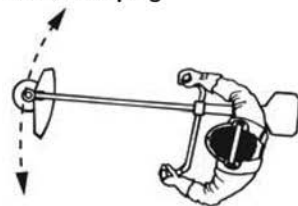

The fan effect of the rotating cord can be used for quick and easy clearing up. Hold the cord parallel to and above the area to be swept and move the tool to and fro.

When cutting and sweeping you should use full throttle to obtain the best results.

5) ROUTINE MAINTENANCE

5.1 Carburettor

Adjusting the idle speed (T)

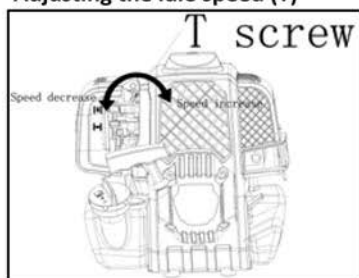

Check that the air filter is clean. When the idle speed is correct, the cutting attachment should not rotate. If adjustment is required, close (turn clockwise) the idle adjustment screw T, with the engine running, until the cutting attachment starts to rotate. Open (turn anticlockwise) the screw until the cutting attachment stops. The idle speed is correctly set when the engine runs smoothly in all

positions, and there is a clear margin to the speed at which the cutting attachment starts to rotate.

WARNING

If the idle speed cannot be adjusted so that the cutting attachment stops, contact your dealer/service workshop. Do not use the machine until it has been correctly adjusted or repaired.

5.2 Air filter

The air filter must be regularly cleaned to remove dust and dirt in order to avoid:

- Carburettor malfunctions
- Starting problems
- Loss of engine power
- Unnecessary wear to engine parts
- Excessive fuel consumption

Clean the filter every 25 hours, or more regularly if conditions are exceptionally dusty.

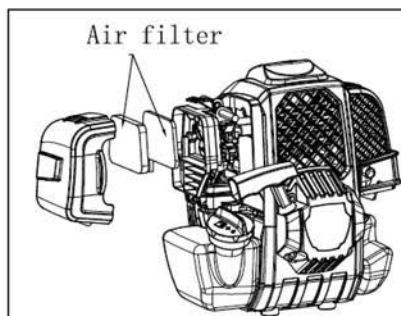

Cleaning the air filter

Remove the air filter cover and take out the filter. Wash it clean in warm, soapy water. Ensure that the filter is dry before refitting it.

An air filter that has been in use for a long time cannot be cleaned completely. The filter must therefore be replaced with a new one at regular intervals. A damaged air filter must always be replaced.

5.3 Fuel filter

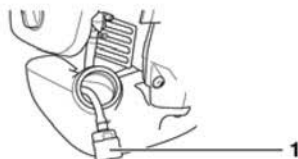

When the engine runs short of fuel supply, check the fuel cap and the fuel filter for blockage.

1 Fuel filter

5.4 Bevel gear

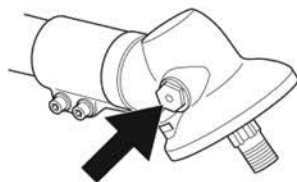

The bevel gear is filled with the right quantity of grease at the factory. However, before using the machine you should check that the bevel gear is filled three-quarters full with grease.

The grease in the bevel gear does not normally need to be changed except if repairs are carried out.

5.5 Spark plug

The spark plug condition is influenced by:

Incorrect carburettor adjustment.

A dirty air filter.

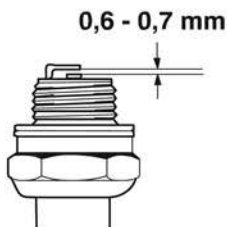

These factors cause deposits on the spark plug electrodes, which may result in operating problems and starting difficulties.

If the machine is low on power, difficult to start or runs poorly at idle speed: always check the spark plug first before taking any further action. If the spark plug is dirty, clean it and check that the electrode gap is 0,6-0,7 mm.

The spark plug should be replaced after about a month in operation or earlier if necessary.

Recommended Spark plug type:

Always use the recommended spark plug type! Use of the wrong spark plug can damage the piston/ cylinder. Check that the spark plug is fitted with a suppressor.

6) MAINTENANCE TIMESCALE

The following intervals apply to normal operating conditions only. If your daily working time is longer or operating conditions are difficult (very dusty work area, etc.), shorten the specified intervals accordingly.		Before starting working	After finishing work daily	After each refueling stop	Every 10 hours	Monthly	Every 12 months	If problem	If damaged	If required
Complete machine	Visual inspection (condition, wear, leaks)	*		*						
	Clean		*							
Control handle	Check operation	*		*						
Air filter	Clean					*	*			*
	Replace								*	*
Filter in fuel tank	Check						*			
	Replace filter					*		*	*	
Carburettor	Check idle setting	*		*						
	Readjust idle									*
Spark plug	Readjust electrode gap							*		
	Replace after 100 hours of operation									
Cooling inlets	Clean									*
All accessible screws	Check							*		
	Retighten									*
Anti-vibration elements	Check	*						*		*
	Replace ¹⁾								*	
Safety labels	Replace								*	
Muffler	Clean ¹⁾							*		
Lubricant	Replace				*					

7) TROUBLE SHOOTING

What to do when....			
Source of problem	Corrective action	Source of problem	Corrective action
1. The engine will not start or will not keep running		3. The engine runs irregularly and lacks in power when revved	
Incorrect starting procedure	Follow the instructions (see chapter 3)	Dirty spark plug or incorrect distance between the electrodes	Check the spark plug (see chapter 5)
Dirty spark plug or incorrect distance between the electrodes	Check the spark plug (see chapter 5)		
Air filter clogged	Clean or replace the filter (see chapter 5)	Carburation problems	Contact your Dealer
Carburation problems	Contact your Dealer	4. The machine starts to vibrate abnormally	
2. The engine starts but is lacking in power		Damaged or loose parts	Stop the machine and disconnect the spark plug cable. Inspect for damage. Check for and tighten any loose parts. Have all checks, repair work and replacements carried out by a specialized Centre only.
Air filter clogged	Clean or replace the filter (see chapter 5)		
Lubricant problem	Replace or add oil		
Carburation problem	Contact your Dealer		

OPERATING INSTRUCTIONS

Technical data	Unit	DUEXBC4335S
Engine displacement	cm ³	33.4
Maximum engine power	kw	0.9
Weight (without fuel, harness, cutting attachment and guard)	kg	7.56
Maximum engine rotation speed	min ⁻¹	8700 for grass trimmer, 9800 for brush cutter
Speed of output shaft	min ⁻¹	6525 for grass trimmer, 7350 for brush cutter
Idling speed range	min ⁻¹	3000 ± 400
Spark plug		TORCH CMR6A
Fuel tank capacity	ml	540
Oil tank capacity	ml	100
Operator ear noise pressure level	dB(A)	93.9
Measurement uncertainty	dB(A)	3
Measured acoustic power level	dB(A)	106.3
Measurement uncertainty	dB(A)	3
Acoustic power level guaranteed	dB(A)	109
Vibration level		
- Right handle	m/s ²	6.01
- Left handle	m/s ²	6.52
Measurement uncertainty	m/s ²	1.5

Recommended cutting attachment	Type	Cutting width (mm)	Thickness of blade/ diameter of cutting line (mm)	Blade centre hole diameter (mm)
Blade	3 teeth, single piece, metal	255	1.6 or 3.0	25.4
Trimmer head	Non-metallic Flexible cutting line	430	2.4	

