

LITTLE BEAVER

Garden Blower

DUETBL228

Instructions

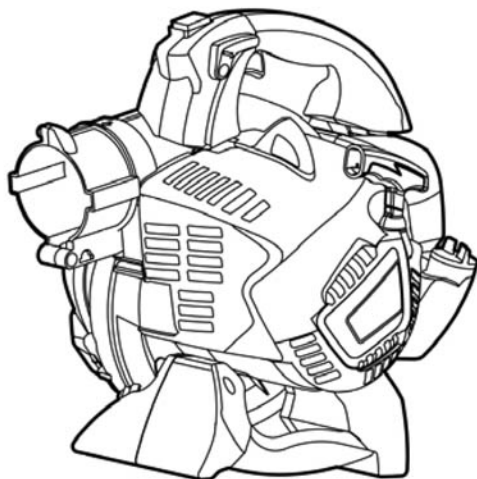

WARNING

- Before using our products, please read this manual carefully to understand the proper use of your unit.
- Keep this instructions handy.

CONTENS

HOW TO READ THE MANUAL

Certain paragraphs in the manual contain particularly significant information and are marked with various levels of highlighting with the following meaning:

NOTE or IMPORTANT

These give details or further information on what has already been said, and aim to prevent damage to the machine or cause other damage.

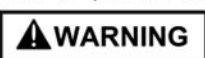
 **WARNING** Non-observance will result in the risk of serious injury or death to oneself or others.

Getting to know the machine	1
Safety regulations	1
Operating instructions	8
1. Prepare the machine	8
2. Preparing to work	9
3. Using the machine	11
4. Operating modes	12
5. Routine maintenance	12
6. Extraordinary maintenance	15
7. Trouble shooting	16
Technical information	17

GETTING TO KNOW MACHINE

MACHINE DESCRIPTION AND USAGE

This machine is a portable gardening device fitted with an engine and, more precisely, a blower/suction device for DIY use.

It basically consists in an engine that activates a rotor which is able to produce a high-speed air flow.

When the accessory tools are fitted, the air flow can be regulated to operate in both blower and suction mode.

Intended use

This machine was designed and manufactured for:

- the movement and accumulation, by blowing, of leaves, grass, debris of various limited weight and modest dimensions.

Any other use differing from the above mentioned ones could be hazardous, harm people and/or damage things and the machine.

User types

This machine is intended for use by consumers, i.e. non-professional operators. The machine is intended for "DIY" use only.

Improper use

The machine must not be used for accumulation of inflammable or explosive products,

hot embers or combustion material without a flame, lit cigarettes, pieces of glass, sharp objects, metal objects, stones and any other object that could be dangerous to the operator and others.

Examples of improper use may include, but are not limited to:

- aiming the air shot towards persons and/or animals;
- allowing object to enter the suction grid;
- using the machine without the accessories specifically supplied by the manufacturer for specific uses, or use of accessories in a way not intended in these instructions;
- use of the machine by more than one person.

DENTIFICATION LABEL (SYMBOL) AND MACHINE COMPONENTS

Your machine must be used carefully. Symbols have therefore been placed on various parts of the machine to remind you of the main precautions to be taken.

Their meaning is explained below. You are also asked to carefully read the safety regulations in the specific chapter of this manual. Replace damaged or illegible labels.



(a). Operate the engine switch

Flipping the switch to the "O" position, immediately the engine stops.

"O" Stop, "I" Start



(b). Warning! Danger. The failure to use this machine correctly can be hazardous for oneself and others. Read the instruction manual before using the machine.



(c). Keep all persons away from the work area whilst using.



(d). If you are using the machine every day in normal conditions, you can be exposed to a noise level of 85 dB (A) or higher. Wear safety glasses and hearing protection.



(e). Wear gloves and protective footwear!



(f). Danger of dismemberment! Never use the machine with the grille open.



(g). Guarantee A-weighted emission noise power level

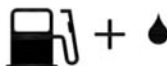

(h). Fuel mixture tank



(i). Close the choke

(j). Open the choke.

(k). Adjustment of carburettor

"H" High speed adjustment, "L" Low speed adjustment



(l). Engine speed continuously variable

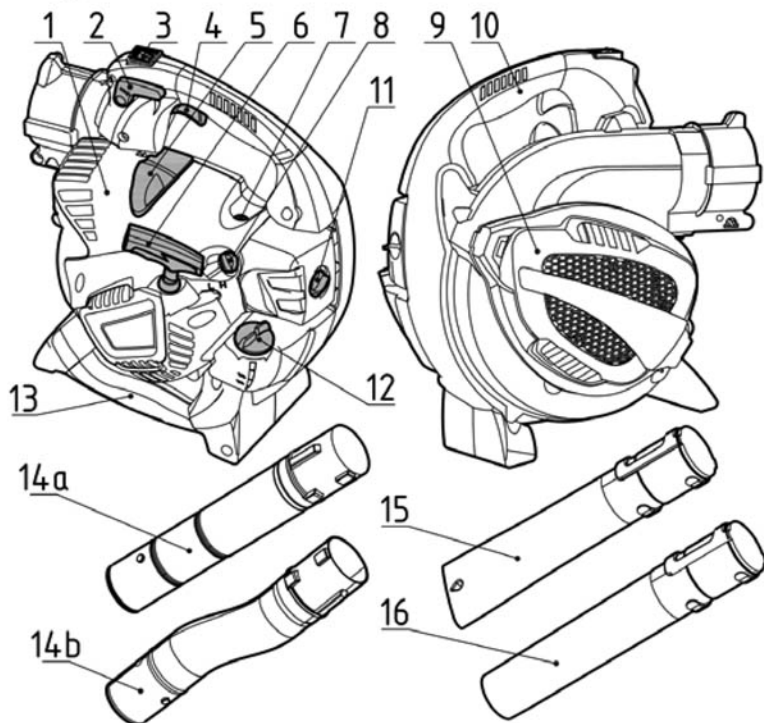

1 Engine

2 Throttle setting device

3 Engine switch

4 Throttle trigger

5 Spark plug

6 Starter handle

7 Primer blub

8 Choke knob

9 Intake grille

10 Upper handle

11 Air filter screw

12 Fuel tank cap

13 Lower handle

14a First blow tube
(straight)

14b First blow tube

(curving)

15 Second blow tube
(flat end)16 Second blow tube
(round end)

SAFETY REGULATIONS

This machine is extremely noisy and operators must wear acoustic protection equipment.

A) TRAINING

- 1) **WARNING!** Read these instructions carefully before operating the machine. Become acquainted with the controls and the proper use of the machine. Learn how to stop the engine quickly.
- 2) Never allow children or people unfamiliar with these instructions to use the machine. Local laws can restrict the minimum age of the operator.
- 3) Never use the machine if the user is tired or unwell, or has taken medicine, drugs, alcohol or any substances which may slow his reflexes and compromise his judgement.
- 4) Bear in mind that the operator or user is responsible for accidents or unexpected events occurring to other people or their property.
- 5) If the machine is sold or lent to others, make sure that the operator looks over the user instructions contained in this manual.

B) PRELIMINARY OPERATIONS

- 1) Always wear adequate clothing which does not hamper movements when using the machine.
 - Always wear slim-fitting protective clothes, anti-vibration gloves, protective goggles, half-mask respirator, protective earplugs, anti-shear safety boots with non-slip soles.
 - Never wear scarves, shirts, necklaces or any hanging or flapping accessory that could catch in the machine.
 - Tie your hair back if it is long.
- 2) **WARNING: DANGER!** Petrol is highly flammable.
 - keep the fuel in containers which have been specifically manufactured and homologated for such use;
 - add fuel, using a funnel, only outdoors; do not smoke during this operation and each time fuel is handled;
 - slowly open the fuel tank to allow the pressure inside to decrease gradually;
 - add fuel before starting the engine; never remove the tank cap or add fuel while the engine is running or when the engine is hot;
 - if you have spilt some fuel, do not attempt to start the engine but move the machine away from the area of spillage and avoid creating any source of ignition until the fuel has evaporated and fuel vapours have dissipated;
 - always put the tank and fuel container caps back on and tighten well;
 - immediately clean up all traces of fuel spilt on the machine or on the ground;
 - never start the machine in the same place you refilled it with fuel; the engine must be started in an area at least 3 metres from where you refilled the fuel tank;
 - make sure your clothing does not come into contact with the fuel, on the contrary, change your clothes before starting the engine.

4) Replace faulty or damaged silencers.

5) Before using the machine, carry out an accurate inspection of the machines efficiency and in particular:

- the throttle trigger must move freely, it must not need forcing and should return automatically and rapidly back to the neutral position;
- the engine stop switch must easily move from one position to the other;
- the electric cables and in particular the spark plug cable must be in perfect condition to avoid the generation of any sparks, and the cap must be correctly fitted on the spark plug;
- the machine handgrips and protection devices must be clean and dry and well fastened to the machine;
- the guards must never be damaged;
- the rotor must never be damaged;
- the bag must never be damaged.

6) Thoroughly inspect the whole work area and use a rake or yard brush to manually loosen debris and remove anything that could be projected by the machine (when used as a blower) or be a hazardous source (stones, branches, iron wire, bones etc.)

C) DURING USE

1) Do not operate the engine in a confined space where dangerous carbon monoxide fumes can develop.

2) Work only in daylight or with good artificial light in good visibility conditions.

3) When working in dry dusty soil conditions, it is recommended to moisten the surface slightly.

4) Try not to cause any disturbance. Use this machine at reasonable times of the day only (not early morning or late evening when the noise could cause disturbance).

5) Do not mount equipment or accessories on the machine not foreseen or approved by the manufacturer.

6) Never use the machine:

Without mounting all the accessories foreseen for each use;

When people, especially children or pets are nearby;

In confined spaces, in the presence of fumes, in an explosive environment or close to inflammable materials or electrical equipment.

7) Take on a firm and well-balanced position:

- where possible, avoid working on wet, slippery ground or in any case on uneven or steep ground that does not guarantee stability for the operator;
- never run, but walk carefully paying attention to the lay of the land and any eventual obstacles;
- assess the potential risks of the ground to be worked and take all necessary precautions to ensure your own safety, especially on slopes or on bumpy, slippery or unstable ground.

8) Make sure the machine is securely locked when you start the engine:

- Check that there is nobody within at least 15 metres of the machine's range of

action;

- Do not direct the silencer and therefore the exhaust fumes towards inflammable materials.

9) Do not change the engine settings or over-speed the engine.

10) Do not strain the machine too much and do not use a small machine for heavy-duty works. If you use the right machine, you will reduce the risk of hazards and improve the quality of your work.

11) Ensure the machine does not come into contact with foreign bodies and possible flying debris and dust being thrown up by the air; do not direct the air jet in the direction of people or animals.

12) When used as a blower always pay the utmost attention to prevent removed material or dust from injuring people or animals or damaging property. Always assess wind direction and never work against the wind. Always extend the blower tube correctly so that the air flow works close to the earth.

14) During use keep your hands well away from the intake grille and from the air outlet and do not obstruct the air vents.

15) Stop the engine:

- when mounting or removing accessories for blowing;
- whenever you leave the machine unattended;
- before refuelling;
- when moving between work areas.

16) Stop the engine and disconnect the spark plug cable:

- before checking, cleaning or working on the machine;
- after the intake of a foreign body. Inspect the machine for any damage and make repairs before restarting it again;
- if the machine starts to vibrate abnormally (find and remove the cause of the vibration immediately);
- when the machine is not in use.

17) To avoid the risk of fire, do not leave the machine with the engine hot on leaves, dry grass or other inflammable material.

18) **WARNING** – If something breaks or an accident occurs while working, turn off the engine immediately and move the machine away to prevent further damage; if an accident occurs with injuries or third parties are injured, carry out the first aid measures most suitable for the situation immediately and contact the medical authorities for any necessary health care. Carefully remove any debris that might cause damage or harm persons or animals should they not be seen.

19) **WARNING** The noise and vibration levels shown in these instructions are the maximum levels for use of the machine. Insufficient maintenance has a significant impact on vibration and noise emissions. Consequently, it is necessary to take preventive steps to eliminate possible damage due to high levels of noise and stress from vibration. Maintain the machine well, wear ear protection devices, and take breaks while working.

20) Rotating parts can cause serious injury, avoid contacting the rotating parts when is

still rotate.

21) Don't operate the machine near open windows.

22) Operating the machine with a stable speed and gripping the handle firmly with suitable force can decrease the vibration level. Low engine speed mean low-noise level, so operate the machine at the lowest engine speed necessary to accomplish the task. During a working day, you shall take frequent and adequate breaks to prevent damage from vibration and damage to the ears.

23) Prolonged exposure to vibrations can cause injuries and neurovascular disorders (also called "Raynaud's syndrome" or "white hand"), especially to people suffering from circulation disorders. The symptoms can regard the hands, wrists and fingers and are shown through loss of sensitivity, torpor, itching, pain and discolouring of or structural changes to the skin. These effects can be worsened by low ambient temperatures and/or by gripping the handgrips excessively tightly. If the symptoms occur, the length of time the machine is used must be reduced and a doctor consulted.

D) MAINTENANCE AND STORAGE

1) **WARNING:** Before cleaning or doing maintenance work, disconnect the spark plug cap and read the relevant instructions. Wear proper clothing and protective gloves whenever your hands are at risk.

2) **WARNING:** Never use the machine with worn or damaged parts. Faulty or worn-out parts must always be replaced and not repaired. Only use original spare parts: the use of non-original and/or incorrectly fitted parts will jeopardize the machine and impair safety, may cause accidents or personal injuries for which the Manufacturer is under no circumstance liable or responsible.

3) Any adjustments or maintenance operations not described in this manual must be carried out by your Dealer or a specialized Service Centre with the necessary knowledge and equipment to ensure that the work is done correctly maintaining the machine's original safety level. Any operations performed in unauthorized centres or by unqualified persons will totally invalidate the Warranty and all obligations and responsibilities of the Manufacturer.

4) Keep all nuts and screws tight to be sure the machine is always in safe working condition. Routine maintenance is essential for safety and for maintaining a high performance level.

5) Do not perform any work on the machine that is not described in this manual unless adequately skilled with appropriate tools.

6) Do not store the machine with fuel in the tank in an area where the fuel vapours could reach an open flame, a spark or a strong heat source.

7) Allow the engine to cool down before storing the machine in any enclosure.

8) To reduce fire hazards, keep the engine, exhaust silencer and fuel storage area free from sawdust, branches, leaves, or excessive grease; never leave containers with the debris inside the storage area.

9) If the fuel tank has to be emptied, this should be done outdoors once the engine has cooled down.

- 10) Wear work gloves when performing all maintenance.
- 11) Before putting the machine away, check you have removed wrenches or tools used for maintenance.
- 12) Store the machine out of the reach of children!
- 13) Often inspect the bag to avoid wear and a decrease in quality.

E) TRANSPORTATION AND HANDLING

1) Whenever the machine is to be handled or transported you must:

- Turn off the engine and disconnect the spark plug cap;
- Only hold the machine using the handgrips and position the tubes so that they do not obstruct.

2) When using a vehicle to transport the machine, remove the tubes and position it so that it can cause no danger to persons and fasten it firmly in place to avoid it from tipping over, which may cause damage or fuel spillage.

F) ENVIRONMENTAL PROTECTION

Environmental protection should be a priority of considerable importance when using the machine, for the benefit of both social coexistence and the environment in which we live. Try not to cause any disturbance to the surrounding area.

- Scrupulously comply with local regulations and provisions for the disposal of oils, petrol, damaged parts or any elements which have a strong impact on the environment; this waste must not be disposed of as normal waste, it must be separated and taken to specified waste disposal centres where the material will be recycled.
- Scrupulously comply with local regulations and provisions for the disposal of waste materials.
- At the time of decommissioning, do not pollute the environment.

OPERATING INSTRUCTIONS

1. PREPARE THE MACHINE

The machine can be used as a blower; for these uses it is necessary to correctly arrange the appropriate accessories included with the equipment.



Unpacking and completing the assembly should be done on a flat and stable surface, with enough space for moving the machine and its packaging, always making use of suitable equipment.

IMPORTANT The safety systems prevent the engine from starting if the blower tubes are not assembled correctly.

1.1 USE AS A BLOWER (Fig. 1)

– Align the protrusions of the first blower tube (1) with the air outlet nozzle compartments (2), then push the tube until it is fitting firmly in place.

– Align the compartment of the second blower tube (3) with the protrusion (4) of the first tube, push the tube in and rotate it 90 degrees clockwise to one of the two foreseen positions, until it is fitting firmly in place.

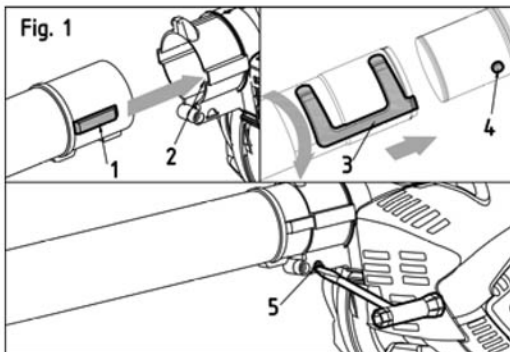

NOTE Fit the second tube with a flat or round end depending on the type of work to be accomplished.

To remove the first tube (1), insert the screwdriver included in the kit in the hole (5) and press firmly until you can slide the tube out from the air outlet nozzle.

2. PREPARING TO WORK

2.1 CHECKING THE MACHINE

Before starting work please:

- check that all the screws on the machine are tightly fastened;
- check that the air filter is clean;
- check that the handgrips are well fastened;
- prepare accessories according to the type of work (as blower) and make sure they are correctly mounted;
- fill with fuel as indicated below.

2.2 PREPARING THE FUEL MIXTURE

This machine is fitted with a two-stroke engine which requires a mixture of petrol and lubricating oil.

IMPORTANT Using petrol alone will damage the engine and is cause for invalidation of the warranty.

IMPORTANT Use only quality fuels and oils to maintain high performance and guarantee the duration of the mechanical parts over time.

2.2.1 Petrol characteristics

Only use unleaded petrol with a fuel grade of at least 90 ON.

IMPORTANT Unleaded petrol tends to create deposits in the container if preserved for more than 2 months Always use fresh petrol!

2.2.2 Oil characteristics

Only use top quality synthetic oil specifically for two-stroke engines.

Your Dealer can provide you with oils which have been specifically developed for this type of engine, and which are capable of guaranteeing a high level of protection.

2.2.3 Preparation and preservation of the fuel mixture



WARNING

Petrol and the fuel mixture are highly inflammable!

- Keep the petrol and fuel mixture in homologated fuel containers, in a safe place, away from any flames or heat sources.
- Never leave the containers within the reach of children.
- Never smoke whilst preparing the mixture and avoid inhaling the petrol fumes.

To prepare the fuel mixture:

- Place about half the amount of petrol in a homologated tank.
- Add all the oil, according to the chart.
- Add the rest of the petrol.
- Close the top and shake well.

IMPORTANT The fuel mixture tends to age. Do not prepare excessive amounts of the fuel mixture to avoid the formation of deposits.

IMPORTANT Keep the petrol and fuel mixture containers separate and easily identifiable to avoid the mistake of using one in place of the other.

IMPORTANT Periodically clean the petrol and fuel mixture containers to remove any eventual deposits.

2.3 REFUELLING



WARNING

Never smoke whilst refuelling and avoid inhaling the petrol fumes.

Carefully open the tank top as pressure could have formed inside.

Before refuelling:

- Place the machine on a flat stable surface, with the fuel tank cap facing upwards.
- Clean the fuel tank cap and the surrounding area to avoid any dirt from entering the tank during refilling.
- Carefully open the fuel tank cap to allow the pressure inside to decrease gradually.

To fuel:

- Shake the tank with the fuel mixture well.
- Using a funnel, pour an amount of fuel mixture suited to the work to be performed in the supplied graduated bottle.
- Refuel without filling the tank to the rim (**Fig. 3**).

NOTE The machine tank is best filled with about half graduated bottle capacity.

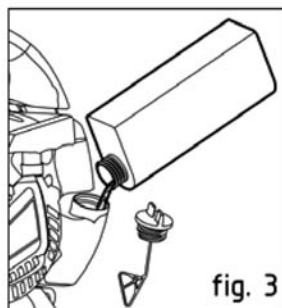

WARNING

Always close the fuel tank cap firmly.

Immediately clean all traces of fuel which may have dripped on the machine or the ground and do not start the engine until the petrol fumes have dissipated.

3. USING THE MACHINE

3.1 STARTING THE MACHINE

Before starting the engine, place the machine on stable ground and make sure blowing are not crushed.

3.1.1 Cold starting (Fig. 4)

A "cold" start of the engine means starting it after at least 5 minutes from when it was switched off or after refuelling.

1. Operate the starter, moving lever (2) to «CHOKE».
2. Press the primer device button (3) 7 to 10 times to prime the carburettor.
3. Hold the machine firmly with one hand on the hand grip (6), in order not to lose control of the machine during starting.
4. Pull the starter rope slowly for 10 - 15 cm until you feel some resistance, then tug it hard a few times until you hear the engine turn over.

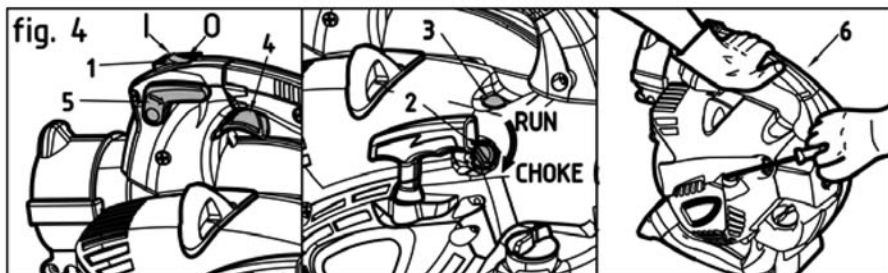

IMPORTANT To avoid breaking the starter rope, do not pull the whole length of it or let it slide along the edge of the cable guide hole. Release the starter gradually, to avoid letting it fly back uncontrollably.

5. Switch the lever (2) to the «RUN» position.
6. Pull the starter grip again, and press the throttle trigger all the way (4) until the engine starts as normal.
7. When the engine has started, press and release the throttle trigger (4) to allow the engine to run idle.
8. Rev the engine a little using the throttle trigger to warm it up before using the machine.

IMPORTANT If the starter rope is pulled repeatedly with the choke on, it may flood the engine and make starting difficult.

If you happen to flood the engine, repeat the hot start procedure a few times to eliminate any excess fuel.

3.1.2 Hot starting

To hot start the engine immediately after it has stopped, follow steps 2 - 3 - 4 - 6 of the above procedure, making sure the primer (3) is activated 2-3 times only.

3.2 ADJUSTING THE SPEED (Fig. 4)

Rotor rpm must be proportionate to the type of work and regulated by the throttle trigger (4) located on the upper handgrip. The throttle trigger can be held in any required position engaging the throttle setting device (5).

3.3 STOPPING THE ENGINE (Fig. 4)

To stop the engine:

- Turn the throttle setting device downwards (5).
- Release the throttle trigger (4).
- Press and hold the switch (1) in the «O» position until the engine switches off, then release the switch which will automatically move to the «I» position ready for the next start procedure.

4. OPERATING MODES

4.1 USE AS A BLOWER

WARNING The machine must always be firmly gripped with your right hand on the upper handgrip during work.

Engine speed should be adjusted to the type of material to be removed:

- use the engine at low speed for lightweight material and small bushes on the lawn;
- use the engine at average speed to move grass and lightweight leaves on pavement or solid ground;
- use the engine at high speed for heavier materials like fresh snow or voluminous dirt.



WARNING Always pay the utmost attention to prevent removed material or dust from injuring people or animals or damaging property. Always assess wind direction and never work against the wind.

4.3 END OF OPERATIONS

When you have finished your work:

- Switch off the engine as indicated above (Chap. 6).
- Disconnect the spark plug cap.

5. ROUTINE MAINTENANCE

WARNING Correct maintenance is essential to maintain the original efficiency and safety of the machine over time.

During maintenance operations:

- Remove the spark plug cap.
- Wait until the engine is sufficiently cold.
- Wear protective gloves.
- Do not work on the machine if not in possession of the necessary skills

and tools.

5.1 STORAGE

After every working session, clean the machine thoroughly to remove all dust and debris, and repair or replace any faulty parts.

The machine must be stored in a dry place away from the elements.

5.2 CYLINDER AND SILENCER

To reduce fire risks, periodically clean the cylinder fins with compressed air and clear the silencer area from dust, leaves or other debris.

5.3 STARTING SYSTEM

To avoid overheating and damage to the engine, always keep the cooling air vents clean and free of sawdust and debris.

The starter rope must be replaced as soon as it shows signs of wear.

5.4 NUTS AND SCREWS

Periodically check that all the nuts and screws are securely tightened and the handgrips are tightly fastened.

IMPORTANT Cleaning the air filter is essential to guarantee the efficiency and duration of the machine. Do not work with a damaged filter or without a filter, as this could permanently damage the engine.

It must be cleaned after every 8-10 working hours.

Clean the filter as follows:

- Loosen the knob (1), remove the cover (2) and the filter element (3).
- Wash the filter element (3) with soap and water. Do not use petrol or other solvents.
- Leave the filter to dry in the open air.
- Replace the filter element (3) and the cover (2) and tighten the knob (1).

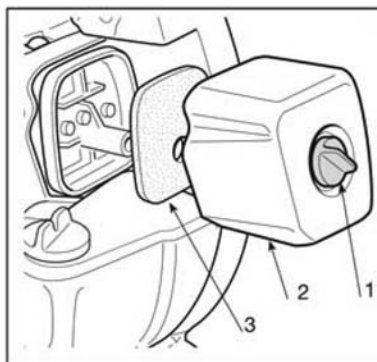

5.6 CHECKING THE SPARK PLUG

Periodically remove and clean the spark plug using a metal brush to get rid of any deposits. Check and reset the correct distance between the electrodes.

Replace the spark plug and fasten it firmly using the supplied wrench.

The spark plug must be replaced

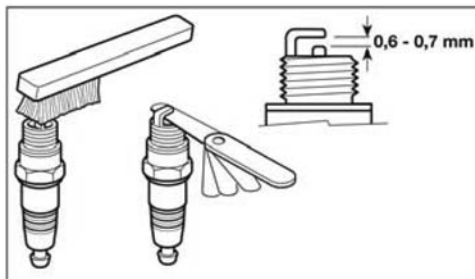

with one with the same characteristics whenever the electrodes have burnt or the insulation has worn, and in any case every 50 working hours.

5.7 CARBURETTOR ADJUSTMENTS

IMPORTANT When the engine tends to switch off or there is not much difference in speed when using the throttle trigger, it is recommended to adjust the carburetion settings. This operation must be performed by your Retailer only.

5.8 LONG PERIODS OF DISUSE

IMPORTANT If the machine will not be used for a period of more than 2-3 months it is recommended to follow some advice to avoid difficulty when you wish to use the machine and to prevent permanent damage to the engine.

5.8.1 Storage

Before putting the machine away:

- Empty the fuel tank.
- Start the engine and run it idle until it comes to a halt, so that it uses up all the fuel that is left in the carburettor.
- Allow the engine to cool down and remove the spark plug cap.

5.8.2 Restarting work

When you wish to start using the machine again:

- Replace the spark plug cap.
- Prepare the machine as indicated in the paragraph entitled "Preparing for work".

5.9 MAINTENANCE TIMESCALE

The following intervals apply to normal operating conditions only. If your daily working time is longer or operating conditions are difficult (very dusty work area, etc.), shorten the specified intervals accordingly.		Before starting working	After finishing work daily	After each refueling stop	Weekly	Monthly	Every 12 months	If problem	If damaged	If required
Complete machine	Visual inspection (condition, wear, leaks)	*		*						
	Clean		*							
Control handle	Check operation	*		*						
Air filter	Clean					*	*			*
	Replace								*	*
Filter in fuel tank	Check						*			
	Replace filter					*		*	*	
Carburettor	Check idle setting	*		*						
	Readjust idle									*
Spark plug	Readjust electrode gap							*		
	Replace after 100 hours of operation									
Cooling inlets	Clean									*
All accessible screws	Check							*		
	Retighten									*
Anti-vibration elements	Check	*						*		*
	Replace ¹⁾								*	
Safety labels	Replace								*	
Muffler	Clean ¹⁾						*			

1) LITTLE BEAVER recommends that this work be done by a LITTLE BEAVER servicing dealer.

Use only the spare parts recommended by LITTLE BEAVER.

6. EXTRAORDINARY MAINTENANCE

This work must be done exclusively by your Dealer.

All and any operations performed in unauthorised centres or by unqualified persons will totally invalidate the warranty.

6.1 FUEL FILTER

Inside the fuel tank there is a filter which prevents impurities from entering the engine. The filter should be replaced once a year by your Retailer.

6.2 CARBURETTOR ADJUSTMENTS

The carburettor is tuned by the manufacturer to achieve maximum performance in all

situations, with a minimum emission of toxic gas in compliance with the regulations in force.

In the case of poor performance contact your Dealer for a check of the carburation and engine.

7. TROUBLE SHOOTING

What to do when....			
Source of problem	Corrective action	Source of problem	Corrective action
1. The engine will not start or will not keep running		3. The engine runs irregularly and lacks in power when revved	
Incorrect starting procedure	Follow the instructions (see chapter 3)	Dirty spark plug or incorrect distance between the electrodes	Check the spark plug (see chapter 5)
Dirty spark plug or incorrect distance between the electrodes	Check the spark plug (see chapter 5)		
		Carburation problems	Contact your Dealer
Air filter clogged	Clean or replace the filter (see chapter 5)	4. The engine makes too much smoke	
Carburation problems	Contact your Dealer	Incorrect composition of the fuel mixture	Prepare the fuel mixture according to the instructions (see chapter 2)
Intake grille open	Close the grille	Carburation problems	Contact your Dealer
		5. The machine starts to vibrate abnormally	
Blower tube not fitted	Fit the tube	Damaged or loose parts	Stop the machine and disconnect the spark plug cable. Inspect for damage. Check for and tighten any loose parts. Have all checks, repair work and replacements carried out by a specialized Centre only.
2. The engine starts but is lacking in power			
Air filter clogged	Clean or replace the filter (see chapter 5)		
Carburation problem	Contact your Dealer		

TECHNICAL INFORMATION

Technical data	Unit	DUETBL228
Capacity	cm ³	27.6
Power	kw	0.8
Maximum engine rotation speed	min ⁻¹	8300
Spark plug		CHAMPION RCJ7Y
Mixture (petrol: 2-stroke oil)		40:1
Fuel tank capacity	ml	400
Operator ear noise pressure level L _{pA}	dB(A)	93.9
Measurement uncertainty	dB(A)	3
Measured acoustic power level	dB(A)	106.6
Measurement uncertainty	dB(A)	3
Acoustic power level guaranteed	dB(A)	109
Vibration level		
- upper handle	m/s ²	2.06
- lower handle	m/s ²	1.33
Measurement uncertainty	m/s ²	1.5
Weight		
- blower	kg	4.7
Air flow		
- blowing	m ³ /h	610
Maximum air speed	m/s	72
Length (without tube)	mm	350
Width (without tube)	mm	250
Height (without tube)	mm	350

