

Original instructions

DUELT38-6 DUELT42-5

LAWN TRACTOR OWNER'S MANUAL

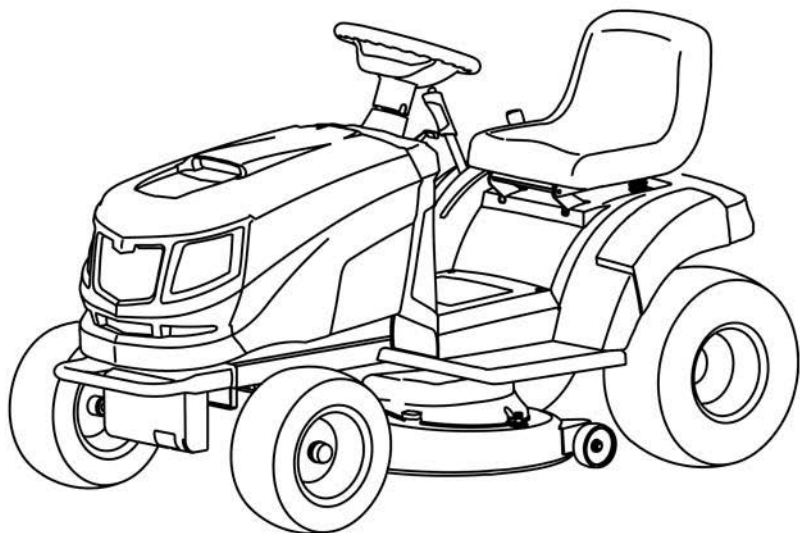

WARNING!
Read this manual carefully before using the machine

CE

INTRODUCTION

Dear Customer,

Thank you for having chosen one of our products. We hope that you will get complete satisfaction from using your new machine and that it will fully meet all your expectations.

This manual has been written to help you become familiar with the machine and use it safely and efficiently. Do not forget that it is an integral part of the machine, so keep it close at hand for future reference and pass it on to the purchaser if you sell the machine.

This new lawn mower has been designed and built in compliance with current standards, and is safe and reliable if used for cutting and collecting grass following the instructions given in this manual (**proper usage**). If you use the machine in any other way or ignore the instructions for safe use, maintenance and repair, it is considered "**incorrect usage**". In this case, the warranty is automatically voided and the manufacturer is not held responsible for damage or injury to oneself or others.

Since we regular improve our products, you may find slight differences between your machine and the descriptions contained in this manual. Modifications can be made to the machine without notice and without the obligation to update the manual, although the essential safety and function characteristics will remain unaltered. If in doubt, do not hesitate to contact your dealer. And now enjoy your work!

AFTER-SALES SERVICE

This manual gives all the necessary instructions for using the machine and carrying out basic maintenance.

Any adjustments or maintenance operations not described in this manual must be carried out by your Dealer or a specialized Service Centre. Both have the necessary knowledge and equipment to ensure that the work is done correctly without affecting the safety of the machine.

This will help you keep your new purchase in peak performance and maintain its value over time.

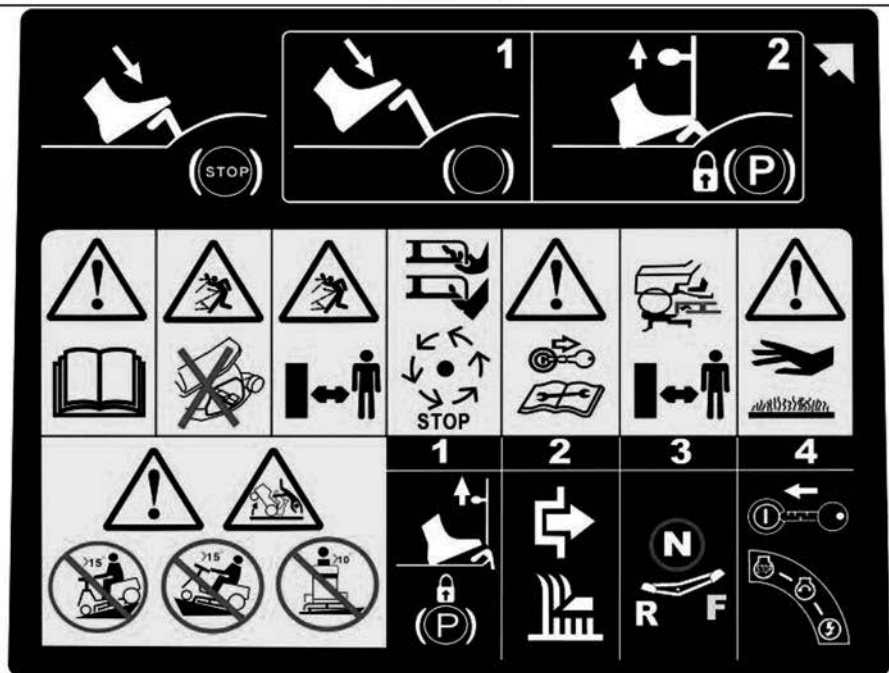

IMPORTANT

The lawnmower must always be used with utmost caution. So that safety precautions and operating instructions are always readily on hand, labels have been affixed to the machine showing pictographs illustrating the main operating precautions.

Because these labels, according to applicable safety standards, are considered an integral part of the machine, the user is therefore responsible for replacing them in the event of their becoming detached or illegible.

For any replacement, contact your dealer.

LABEL POSITION DUFLT38-6

Keep hands and feet away.
Gardez les mains et les pieds éloignés.

98

Caution/Mise en garde.
Shield or grass catcher must
be in place while mowing.
Le bouclier ou le bac à
herbe doit être en place
pendant la tonte.

1 2
h(P)

STOP 2 3 4

g R F

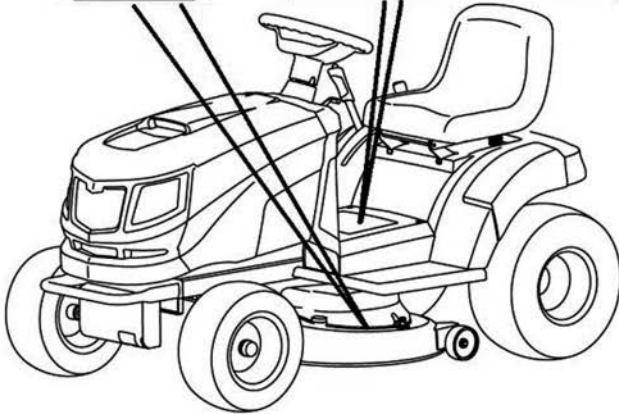

CE

STOP

11
2
3
4
5
6
7
12

STOP

LABEL POSITION DUELT42-5

Keep hands and feet away.
Gardez les mains et les pieds éloignés.



108

Caution/Mise en garde.
Shield or grass catcher must
be in place while mowing.
Le bouclier ou le bac à
herbe doit être en place
pendant la tonte.



1 2

6 (P)

STOP

1 2 3 4

STOP

N R F

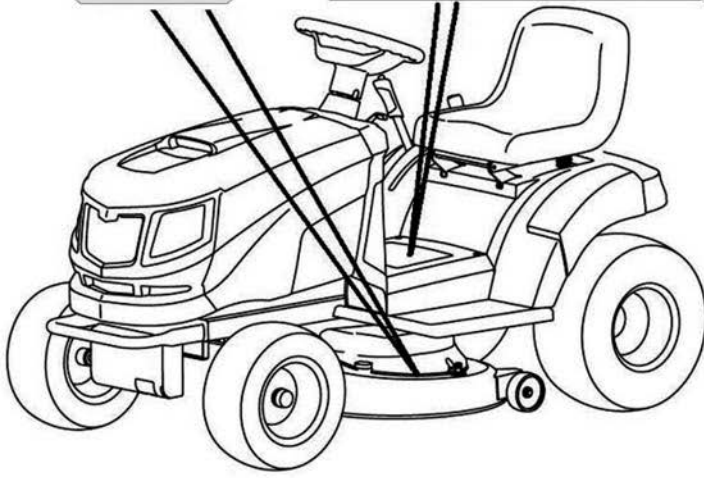
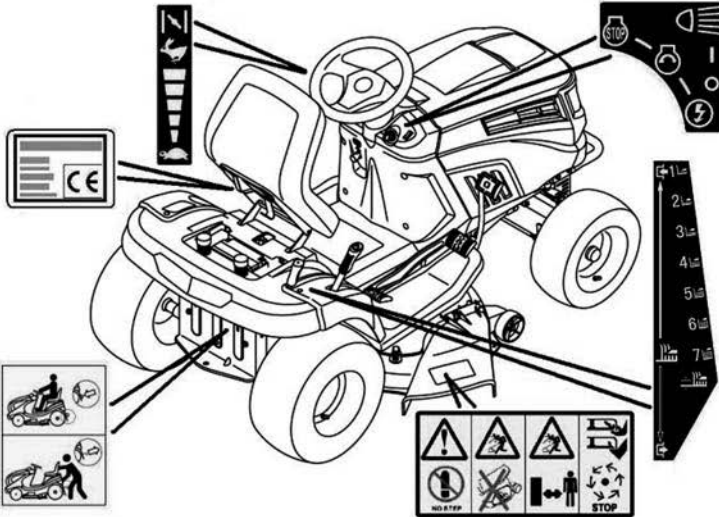
CE

STOP

1 2 3 4 5 6 7

STOP

INTRODUCTION

TABLE OF CONTENTS

TABLE OF CONTENTS

| | |
|---|----|
| 1. SAFETY..... | 1 |
| 2. IDENTIFICATION OF THE MACHINE AND COMPONENTS | 7 |
| 3. UNPACKING AND ASSEMBLY | 8 |
| 4. CONTROLS AND INSTRUMENTS | 13 |
| 5. HOW TO USE THE MACHINE | 16 |
| 5.1 SAFETY RECOMMENDATIONS | 16 |
| 5.2 WHY THE SAFETY DEVICES CUT IN | 16 |
| 5.3 DIRECTIONS BEFORE STARTING WORK | 17 |
| 5.4 USING THE MACHINE..... | 18 |
| 5.5 USING ON SLOPING GROUND | 22 |
| 5.6 TRANSPORTING | 23 |
| 5.7 LAWN MAINTENANCE | 23 |
| 6. MAINTENANCE | 25 |
| 6.1 SAFETY RECOMMENDATIONS | 25 |
| 6.2 SCHEDULED MAINTENANCE | 25 |
| 6.3 CHECKS AND ADJUSTMENTS..... | 27 |
| 6.4 DISMANTLING AND REPLACEMENT..... | 28 |
| 6.5 LUBRICATION | 30 |
| 7. SPECIFICATIONS | 31 |

1. SAFETY

1.1 HOW TO READ THE MANUAL

Some paragraphs in the manual containing important information regarding safety and operation are emphasized in the following ways.

NOTE or **IMPORTANT** These give details or further information on what has already been said, in the aim to prevent damage to the machine.

▲ WARNING! *Non-observance will result in the risk of injury to oneself or others.*

▲ DANGER! *Non-observance will result in the risk of serious injury or death to oneself or others.*

This manual describes various versions of the machine

NOTE *Positions on the machine, such as “front”, “back”, “left” or “right” hand side, refer to the direction of forward travel*

IMPORTANT *For all operations regarding the use and maintenance of the engine not described in this manual, refer to the relevant manuals which form an integral part of all the documentation supplied with the machine.*

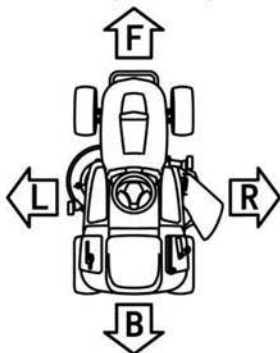

1.2 GENERAL SAFETY REGULATIONS

▲ WARNING! *Read carefully before using the machine.*

A) TRAINING

1) **Read the instructions carefully.** Be familiar with the controls and how to use the equipment properly.

2) Never let children or people unfamiliar with these instructions use the machine. Local regulations can restrict the age of the user.

 3) **Never mow while people, especially children, or pets nearby; Never mow while dark.**

4) Keep in mind that the operator or user is responsible for accidents or hazards occurring to other people or their property.

5) Do not carry passengers.

6) All drivers should seek and obtain professional and practical instruction. Such instruction should emphasize:

- the need for care and concentration when working with ride-on machines;
- you can not use the brake to regain control of a ride-on machine sliding down a slope. The main reasons for loss of control are:
 - insufficient wheel grip;
 - over-speeding;
 - inadequate braking;
 - the type of machine is unsuitable for its task;
 - unawareness of the effect of ground conditions, especially slopes;
 - incorrect hitching and load distribution

B) PREPARATION



1) **While mowing, always wear sturdy footwear and long trousers.** Do not operate the equipment barefoot or wearing open sandals.

2) Thoroughly inspect the area where the equipment is to be used and remove all objects which can be ejected from the machine.



3) **DANGER! Petrol is highly flammable:**

– store fuel in containers specifically designed for this purpose;



– refuel outdoors only and do not smoke while refueling;

– **add fuel before starting the engine. Never remove the cap of the fuel tank or add petrol while the engine is running or when the engine is hot;**



– if you spill petrol, do not start the engine and move the machine away from the area of spillage. Do not create any source of ignition until the petrol steam have evaporated;

– put back and tighten all fuel tank and container caps securely.

4) Replace faulty silencers.

5) **Before use**, always inspect the machine to check that the blades, blade bolts and cutter assembly are not worn or damaged. Replace worn or damaged blades and bolts in sets to preserve balance.

6) On multi-bladed machines, remember that the rotation of one blade can cause other blades to rotate

C) OPERATION

1) Do not start the engine in a confined space where dangerous carbon monoxide fumes can collect.

2) Mow only in daylight or good artificial light.

3) Before starting the engine, disengage the blades and shift into neutral.

4) **Do not use the machine on lawns with gradients of more than 15°(27%) ; do not use the machine on lawns with side gradients above 10°(18%).**

5) **Remember there is no such thing as a “safe” slope.** Travelling on grass slopes requires particular care. To guard against overturning:

- do not stop or start suddenly when going up or downhill;
- engage the drive slowly and always keep the machine in gear, especially when travelling downhill;
- machine speeds should be kept low on slopes and during tight turns;

- stay alert for humps and hollows and other hidden hazards;

- **never mow across the face of the slope.**

6) Use care when pulling loads or using heavy equipment:

- use only approved drawbar hitch points;
- limit loads to those you can safely control;
- do not turn sharply. Use care when reversing;
- use counterweight(s) or wheel weights whenever advised in the

instructions manual.

7) Stop the blades before crossing surfaces other than grass.

8) **Never use the machine with damaged guards, or without the safety protective devices in place.**

9) **Do not change the engine governor settings or overspeed the engine.** Operating the engine at excessive speed can increase the risk of personal injury.

10) Before leaving the driving seat:

- disengage the blades and lower the attachments;
- go into neutral and apply the parking brake;
- stop the engine and remove the ignition key.

11) **Disengage the blades, stop the engine and remove the ignition key:**

- before clearing blockages or unclogging the collector channel;
- before cleaning, checking or servicing the machine;

SAFETY

– after striking a foreign object. Inspect the machine for damage and make repairs before restarting and operating the machine;

– If the machine starts to vibrate abnormally (check for the causes immediately).

12) Disengage the blades for transport or whenever they are not in use.

13) **Stop the engine and disengage the blades:**

– before refueling;

– before making height adjustment unless adjustment can be made from the operator's position.

14) Reduce the throttle during engine run-out. If the engine is provided with a shut-off valve, cut off the fuel when you have finished mowing.

15) Watch out for traffic when crossing or near roadways.

16) Never direct discharge of material toward bystanders nor allow anyone near the machine while in operation.

D) MAINTENANCE AND STORAGE

1) Keep all nuts, bolts and screws tight to be sure the equipment is in safe working condition.

2) Never store the equipment with petrol in the tank inside a building where fumes may reach an open flame or spark.

3) Allow the engine to cool before storing in any enclosure.

4) To reduce fire hazards, keep the engine, silencer, battery compartment and petrol storage area free of grass, leaves, or excessive grease.

5) Check the grass-catcher frequently for wear or deterioration.

6) **Replace worn or damaged parts for safety purposes.**

7) If the fuel tank has to be drained, this should be done outdoors.

8) On multi-bladed machines, remember that the rotation of one blade can cause other blades to rotate.

9) When the machine is to be parked, stored or left unattended, lower the cutting means unless a positive mechanical lock is used.

1.3 SAFETY LABELS

Your machine must be used with care. This is why labels with illustrations have been placed on the machine, to remind you of the main precautions to take during use.

These labels are to be considered an integral part of the machine.

Should a label come off or become illegible, contact your dealer to replace it. Their meaning is explained below.

**Warning:**

Read the instructions before operating this machine.

**Warning:**

Disconnect the ignition key and read the instructions before carrying out any repair or maintenance work.

**Warning:**

No step on the deck or discharge guard.

**Danger!****Ejected objects:**

Do not operate without the discharge guard or grass-catcher in place.

**Danger!****Ejected objects:**

Keep bystanders away

**Danger!****Dismemberment:**

Make sure that children stay clear of the machine at all time when engine is running

**Danger!****Risk of injury.**

Blades in movement, Do not put hands or feet near. The blade will continue turning for sometime after switching

off the engine or disabling the blade control

**Danger!****Risk of burns**

Wait for the engine to completely cool down before making any adjustments or servicing

the engine itself

**Danger!****Risk of serious injury.**

Keep hands and feet away before the blade and all the moving parts to come to a halt.

**Danger!****Risk of overturning on steep gradients**

Do not use the machine on lawns with gradients of more than 15° (27%).

Do not use the machine on lawns with side gradients above 10° (18%).

1.4 REGULATIONS FOR TOWING

A kit for towing a small trailer is available on request, this accessory is to be fitted following the instructions provided, When using the towing kit, Do not exceed the recommended loads stated on the label and follow the safety instructions.

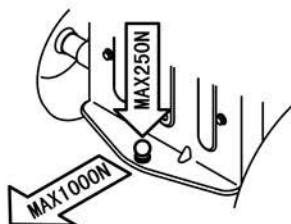

2. IDENTIFICATION OF THE MACHINE AND COMPONENTS

2.1 IDENTIFICATION OF THE MACHINE

The label located in the seat bracket has the essential data of each machine

1. Name and address of manufacturer.
2. Type of machine.
3. Blades speed in r.p.m (if indicated)
4. Cutting width
5. Year of manufacture
6. Weight in kg.
7. engine power.
8. Serial number.
9. Acoustic power level according to directive 2000/14/CE.
10. Conformity mark according to directive 2006/42/EEC.

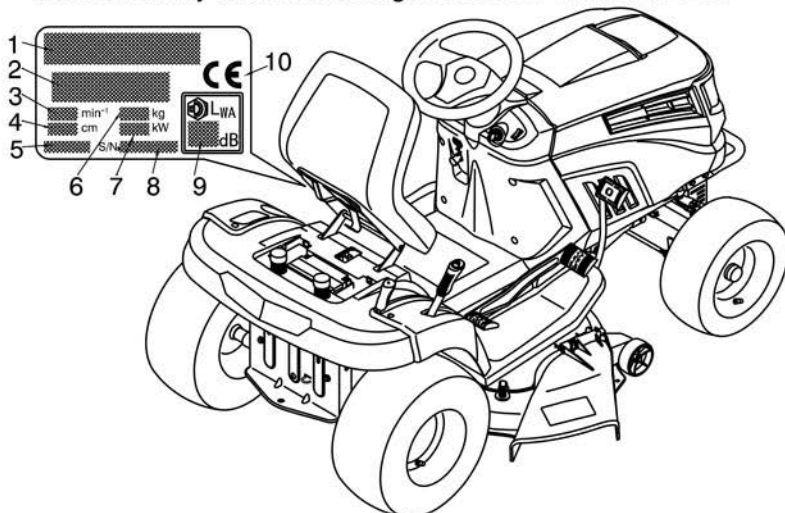

2.2 IDENTIFICATION OF MAIN COMPONENTS

The main components of the machine as following:

- 1) Engine cover.
- 2) Engine
- 3) Steering wheel
- 4) Ignition key.
- 5) Driving seat
- 6) Parking brake lever.
- 7) Battery
- 8) Front wheels.
- 9) Brake pedal
- 10) Drive engagement pedal
- 11) Discharge guard
- 12) Rotating blade
- 13) Blade deck
- 14) Rear driving wheels.
- 15) Lever to release the hydrostatic transmission
- 16) Engine throttle lever.
- 17) Blade deck and cutting height adjustment up/down lever.
- 18) Blade rotation engagement lever.
- 19) Notice and safety labels

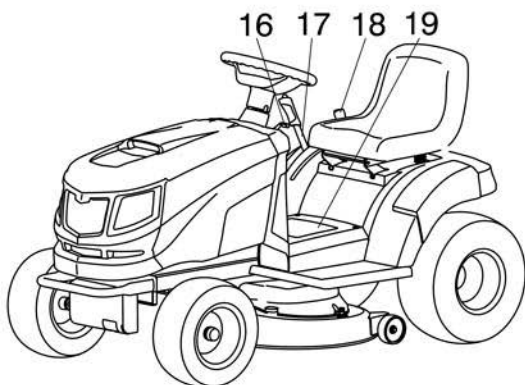
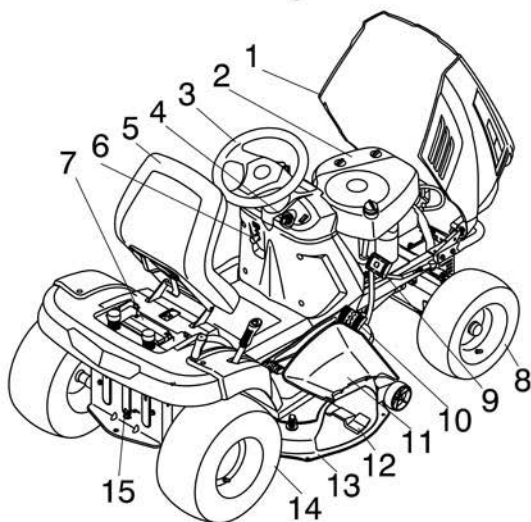

3. UNPACKING AND ASSEMBLY

For storage and transport purposes, some components of the machine are not installed in the factory and have to be assembled after unpacking. Follow the instructions below

IMPORTANT

The machine is supplied without engine oil or fuel. Before starting the engine, fill with oil and fuel following the instructions given in the engine manual.

3.1 UNPACKING

When unpacking the machine, take care to gather all individual parts and fittings, and do not damage the cutting deck when taking the machine off the pallet.

Please remove the 6 bolts at the bottom of the packaging shelf at first, then you can lift up the upper frame so as to free the machine (operation to be performed by two people). And cut the fixed wire at the front and the rear of the mower frame, then you move out the machine from the pallet.

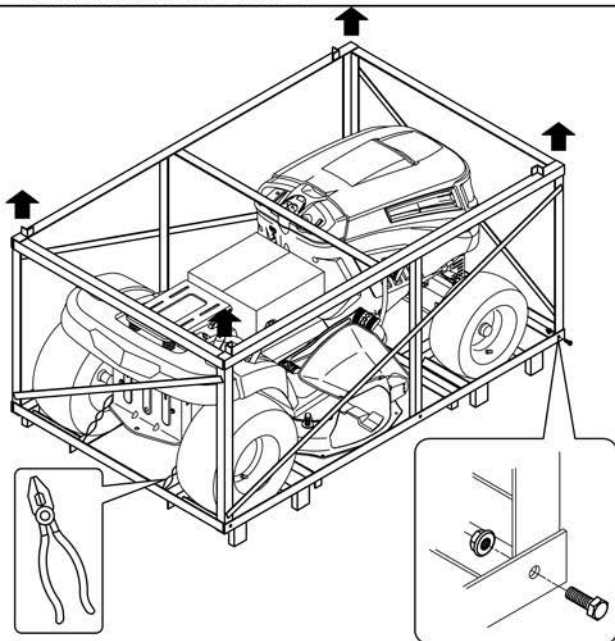

The packaging contains

1. machine body;
2. Battery;
3. Steering wheel;
4. Steering connect shaft;
5. Steering shaft cover;
6. Wheel;
7. Battery bolt;
8. instruction manual;
9. Nuts, bolts, washers, bushing and starter key;
10. Tools;
11. Seat

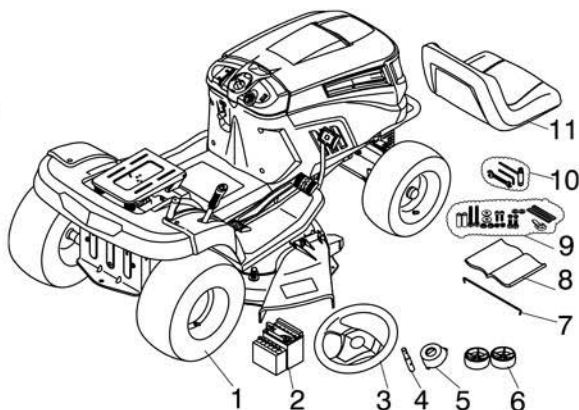

NOTE

To prevent damage to the cutting deck, raise it to its maximum height and take utmost care when taking the machine off the pallet

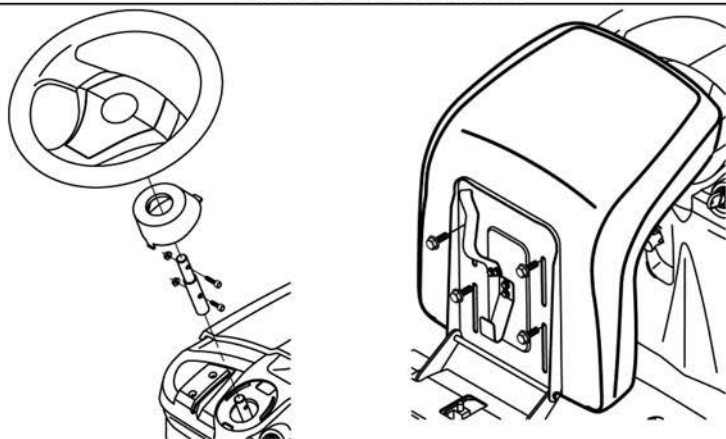

3.2 FITTING THE STEERING WHEEL

Put the machine on a flat surface and straighten up the front wheels. Fit the shaft onto the protruding shaft using the bolt and nut.

Fit the steering wheel onto the steering connect shaft with the spokes directed towards the seat,

3.3 FITTING THE SEAT

Mount the seat on the plate using the screws

3.4 CONNECTING THE BATTERY

(for models with power start only)



IMPORTANT The battery is housed in a box together with the bottle of electrolytic fluid, pre-dosed separately for the 6 elements.



Danger: FILLING SYSTEM

Before filling the battery, carefully read the following instructions relating to "how to add electrolytic fluid"



The electrolytic fluid is a solution of sulfuric acid.

Danger: Sulfuric acid is poisonous

Danger: Sulfuric acid is corrosive Sulfuric acid can cause blindness or severe burns.



Wear protective eyewear.



In case of eyes or skin coming into contact with the electrolytic fluid, immediately rinse the eyes and/or skin with running water for at least 15 minutes and then see a doctor as soon as possible.



Danger: Keep out of reach of children.



Danger: Do not detach or cut the aluminum blades that seal the 6 bottle elements.



Danger: To start the battery, the operator must:

- 1) Take the battery out of the box and rest it on a sturdy surface. Take off the multiple cap closing the 6 elements
- 2) Position the bottle of electrolytic liquid above the battery holes



being careful to keep it in "vertical" position. **DO NOT** hold it at an angle

Press the bottle so the special electrolytic fluid introduction tubes, (present on the battery), perforate the sealed tangs of the bottle and thus allow

the fluid to flow from the bottle into the battery. If necessary, lightly tap the bottle to allow the fluid to flow into the six elements

Wait for all the liquid to flow into the battery before detaching the bottle

- 3) Replace the multiple cap and press it well down

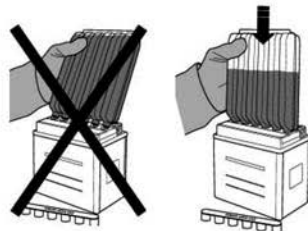

Danger: Never open the caps.

Danger: Never add any more electrolytic fluid.



Danger: Never overturn the battery.

Danger: Never throw the battery away into the environment. If the battery has to be changed, follow the disposal procedures laid down by local authorities

- 4) Fit the battery in its housing.



IMPORTANT

Position the battery with the polarities (+) and (-)

5) Connect the battery connectors to the machine connection leads and tighten the 2 screws. then cover the protective cap for the 2 wire is in place.

6) Secure the battery with the small rubber and bolt.

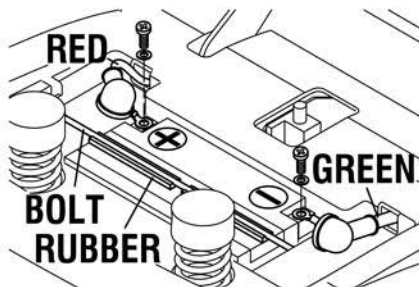

IMPORTANT Use the battery after 30 minutes from filling with electrolytic fluid.

NOTE

This machine used the following battery:

YTX20L-BS, 12 V, 18Ah.

3.5 MOUNTING THE DECK WHEEL

Mounting the two-deck wheel on the deck using the bolts, bushing, washer and nuts.

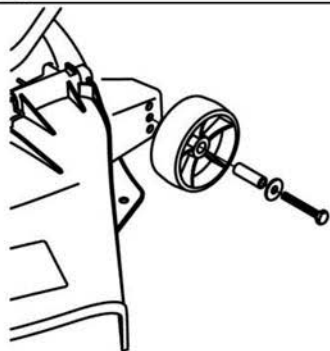

3.6 MOUNTING THE FRONT BUMPER

Mounting the front bumper on the bottom of the frame using the screws.

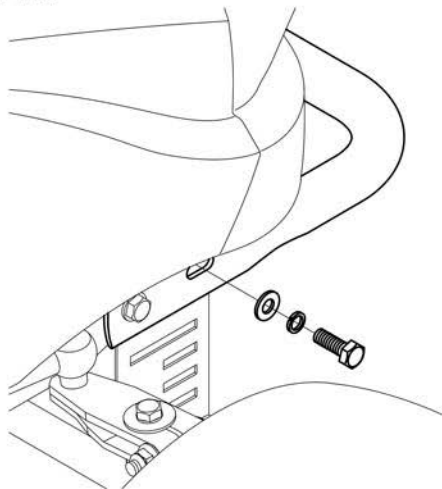

4. CONTROLS AND INSTRUMENTS

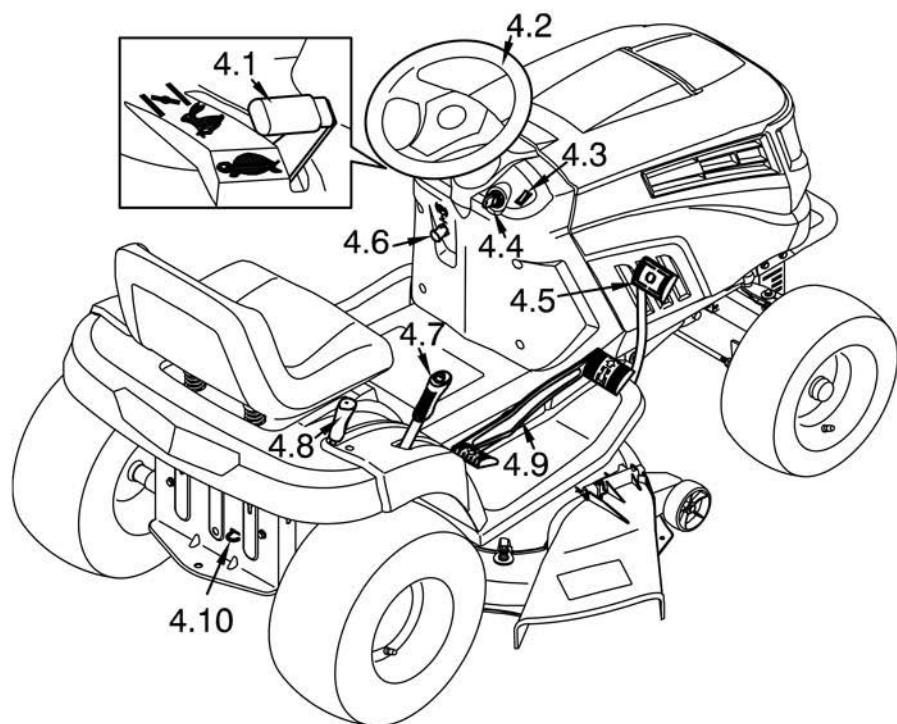

4.1 THROTTLE LEVER

This regulates the engine revs, The positions are indicated on a label showing the following symbols:



«CHOKE» cold starting



«SLOW» for minimum engine speed



«FAST» for maximum engine speed

– The «CHOKE» position enriches the mixture so must only be used for the time necessary when starting from cold.

– When moving from one area to another, put the lever in a position between «SLOW» and «FAST».

– When cutting, shift into «FAST»

4.2 STEERING WHEEL

Turns the front wheels

4.3 HEADLIGHT SWITCH

For turning on the headlights when the key is in the «ON» position

4.4 KEY IGNITION SWITCH

This key operated control has three positions:



«OFF» everything is switched off.



«ON» activates all parts



«START» connects the starter motor

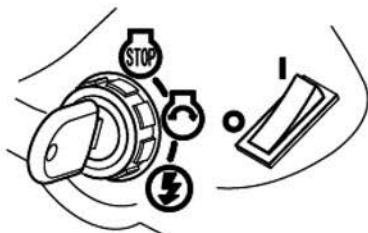

If you release the key on «START», it will automatically return to «ON»

4.5 BRAKE PEDAL

This pedal works the brake on the rear wheels.

4.6 PARKING BRAKE LEVER

With machine stopped: **1)** keep the pedal pressed; **2)** lift the parking brake lever and keep lifted; **3)** release the pedal.



This way, the rear wheels remain braked. To release the parking brake, fully press the pedal (the parking brake lever is automatically released and returns to down

position).

NOTE

The engine only can be started at the parking position.

4.7 CUTTING HEIGHT ADJUSTMENT LEVER



Lifts or lowers the blade deck and thereby adjusts the grass cutting height. There are seven positions for this lever

(shown as «1» to «7» on the label), which correspond to various heights between 30 and 90 mm

To go from one height to another, press the button on the handle and accompany the lever to the required position. When the button is released, the lever remains in the selected position.

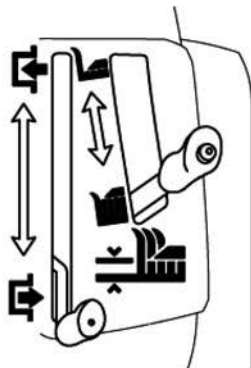

4.8 BLADE ROTATION ENGAGEMENT LEVER

Starts or stops blade rotation



Blade engaged



Blade disengaged

4.9 DRIVE ENGAGEMENT PADAL

This pedal engages drive in the wheels as well as modulating the machine's forward and reverse speeds.

—To engage forward drive, press it towards «F» with your toecap. As you increase the pressure on the pedal, the speed of the machine increases.

—Reverse is engaged by pressing the pedal with the heel towards «R».

—The pedal automatically goes into neutral «N» when released.

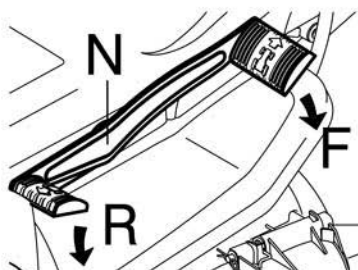

WARNING!

Reverse must only be engaged when the machine is stopped.

NOTE

Drive must be release the parking brake.

4.10 LEVER TO RELEASE THE HYDROSTATIC TRANSMISSION

This lever has two positions as shown on the label:

«A» = Transmission engaged: for all uses, when moving and during cutting;

«B» = Transmission disengaged: this makes it much easier to move the machine by hand with the **engine turned off**.

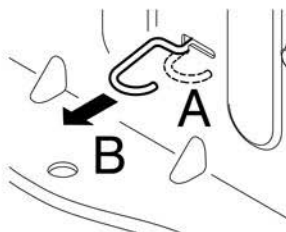

IMPORTANT

To avoid damage to the transmission unit, this operation must be carried out only when the engine has stopped.

5. HOW TO USE THE MACHINE

5.1 SAFETY RECOMMENDATIONS

⚠ DANGER!

The machine must only be used for the purpose for which it was designed (cutting grass).

Do not tamper with or remove the safety devices fitted on the machine.

REMEMBER THAT THE USER IS ALWAYS RESPONSIBLE FOR DAMAGE AND INJURY TO OTHERS. *Before using the machine:*

- read the general safety regulations, paying particular attention to driving and cutting on slopes;*
- carefully read the instructions for use, make sure you are familiar with the controls and know how to stop the blades and the engine quickly;*
- never put your hands or feet next to or beneath the rotating parts and always keep away from the exit.*

Do not use the machine when in a precarious state of health or under the effect of medicine or any other substances that can reduce your reflex actions and your ability to concentrate. It is the user's responsibility to assess the potential risk of the area where work is to be carried out, and to take all the necessary precautions to ensure his own safety and that of others, particularly on slopes or rough, slippery and unstable ground.

Do not leave the machine on high grass with the engine running to avoid the risk of starting a fire.

⚠ WARNING!

Do not use the machine on lawns with gradients of more than 15°(27%). Do not use the machine on lawns with side gradients above 10°(18%). If the machine is likely to be used mostly on sloping ground fit counterweights beneath the cross-member of the front wheels. These improve stability at the front and reduce the chances of tipping over.

IMPORTANT

All the references relating to the positions of controls are described in chapter 4.

5.2 WHY THE SAFETY DEVICES CUT IN

The safety devices work in two ways:

- they prevent the engine from starting if all the safety requirements have not been met;*
- they stop the engine if even just one of the safety requirements is lacking.*

a) *To start the engine, it is necessary that:*

- the blades are not engaged;*
- the parking brake is engaged and the transmission is disengaged;*

b) The engine stops when:

- the operator leaves his seat and the parking brake is disengaged;
- the operator leaves his seat and the blades are engaged;
- the blades are engaged and the machine is reverse.

5.3 DIRECTIONS BEFORE STARTING WORK

Before starting to mow, it is necessary to carry out several checks and operations to ensure you can work efficiently and in maximum safety.

5.3.1 Seat adjustment

To change the seat position, loosen the four fixing bolts and slide it along the slots.

Once you have found the right position, tighten the four screws.

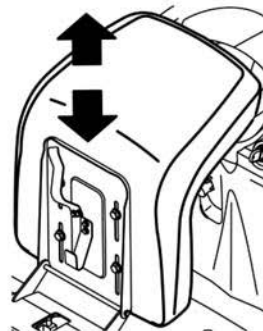

5.3.2 Tire pressure

Having the right tire pressure is the main condition for ensuring that the cutting deck is horizontal and mows evenly.

Unscrew the valve caps and connect a compressed air line with a gauge to the valves.

The pressures are:

- FRONT 1.0 bar (15 x 6.0-6)
- REAR 1.2 bar (18 x 8.5-8)

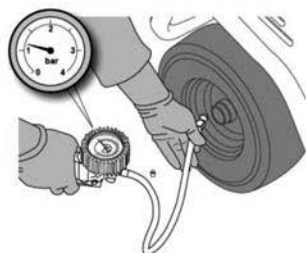

5.3.3 Checking the fuel and oil

NOTE

The engine manual indicates what type of oil and fuel you can use.

With the engine off, check the oil level.

According to the instructions in the engine manual, this must be between the MIN and MAX marks on the dipstick.

Refuel using a funnel, but do not completely fill the tank. The tank's capacity is about 7.5 liters.

▲ DANGER!

Refueling should be carried out in an open or well ventilated area with the engine off. Always remember that petrol fumes are inflammable.

DO NOT USE A NAKED FLAME TO LOOK INSIDE THE TANK AND DO NOT SMOKE WHEN REFUELLING



IMPORTANT

Do not drip petrol onto the plastic parts to avoid damaging them. In the event of accidental spills or leaks, rinse immediately with water. The warranty does not cover for damage to plastic parts of the bodywork or the engine caused by petrol.

5.3.4 Checking machine safety and efficiency

1. Check that the safety devices function as described.(see 5.2)
2. Check that the brake is in perfect working order.
3. Do not start mowing if the blades vibrate or if you are unsure whether they are sharp enough. Always remember that:
 - A badly sharpened blade pulls at the grass and causes the lawn to turn yellow.
 - A loose blade causes unwanted vibrations and can be dangerous.

▲ WARNING!

Do not use the machine if you are unsure whether it is working safely or efficiently. If in doubt, contact your Dealer immediately to make the necessary checks and repairs.

5.4 USING THE MACHINE

5.4.1 Starting

▲ DANGER!

The engine must be started in an open or well ventilated area! ALWAYS REMEMBER THAT EXHAUST GASES ARE TOXIC!

To start the engine:

- open the fuel stopcock(to "I");
 - close the engine cover ;
 - lift the cutting deck raised as high as possible.
 - disengage the blades (see 4.8);
 - release the drive engagement pedal into neutral;
 - operate the parking brake (see 4.6);
 - when starting from cold, move the throttle to the«CHOKE» position shown on the label;
 - if the engine is already warm, position the lever between «SLOW» and «FAST»;
 - put in the ignition key and turn to «ON» to make electrical contact, then turn to «START» to start the engine;
 - release the key once the engine has started.
- When the engine has started, move the throttle to «SLOW».

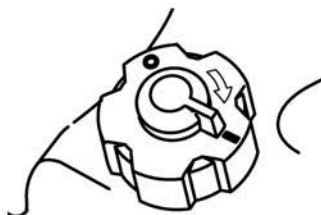

IMPORTANT

The choke must be closed as soon as the engine is running smoothly. Using it when the engine is already warm can foul the spark plugs and cause the engine to run erratically.

NOTE

If there are engine starting problems, do not insist as you can risk running the battery flat and flooding the engine. Turn the key to «OFF», wait for a few seconds and then repeat the operation. If the malfunction persists, refer to the engine manual

IMPORTANT

Always bear in mind that the safety devices prevent the engine from starting if safety requirements have not been met (see 5.2). In these cases, once the situation has been corrected, the key must first be turned back to «OFF» before the engine can be restarted.

5.4.2 Starting and moving without mowing

▲ WARNING!

This machine has not been approved for use on public roads. It has to be used (as indicated by the highway code) in private areas closed to traffic.

When moving the machine, the blades must be disengaged and the cutting deck raised as high as possible. (position «7»)

Position the throttle between «SLOW» and «FAST» and the gear lever in first gear.

Fully press the brake pedal to release the parking brake (see 4.6).

Press the drive engagement pedal (see 4.9) in direction «F» and go to the required speed by progressively increasing pressure on the pedal and moving the accelerator appropriately.

▲ WARNING!

Drive must be engaged in the way already described (see 4.9) to prevent sudden engagement from causing tipping up and loss of control of the vehicle, particularly on slopes.

5.4.3 Braking

First slows down the machine by reducing the engine speed, and then push the pedal right down to lower the speed even more until the machine stops.

NOTE

The machine already slow down considerably by just releasing the drive pedal.

5.4.4 Reverse

IMPORTANT

Reverse must be engaged only when the machine has stopped.

When the machine is stopped, start the reverse movement by pressing the drive engagement pedal in the «R» direction (see 4.9).

5.4.5 Grass cutting

To start cutting:

- move the throttle to «FAST»;
- raise the cutting deck as high as possible;

- engage the blades;
- start moving forwards on the grass very slowly and with utmost caution, as already described;
- regulate the cutting height and speed considering the conditions of the lawn. (the height, density and dampness of the grass).

▲ WARNING! *When cutting on sloping ground, reduce your speed to ensure safe conditions.*

Whatever the conditions, always reduce the speed if you notice a drop in engine speed

– if you travel too fast compared to the amount of grass being cut, you will not be able to mow the grass well.

Disengage the blades and raise the cutting deck as high as possible whenever you need to get past an obstacle.

5.4.6 Unblocking the collector channel

Cutting very tall or wet grass, particularly at excessively high speed, can clog up the collector channel. If this happens proceed as follows:

- stop moving forward, disengage the blades and stop the engine;
- open the discharge guard;
- remove the grass cuttings; you can reach them from the exit of the collector channel.

▲ WARNING! *This job must only be performed with the engine turned off.*

5.4.7 End of mowing

When you have finished mowing, disengage the blades, lower the engine speed and ride the machine with the cutting deck raised as high as possible.

5.4.8 End of work

Stop the machine, move the throttle to «SLOW» and turn off the engine by turning the key to «OFF».

When the engine has stopped, close the fuel stopcock.

▲ WARNING! *To avoid backfire, position the throttle on «SLOW» for 20 seconds before stopping the engine*

▲ WARNING! *Always take out the ignition key before leaving the machine unattended!*

IMPORTANT *To keep the battery charged, do not leave the key in the «ON» position when the engine is not running.*

5.4.9 Cleaning the machine

After use, clean the outside of the machine, empty the grass-catcher or discharge guard, and shake it to remove grass and other debris.

Clean the plastic parts of the body with a damp sponge using water

and detergent, taking care not to wet the engine, the electrical parts or the electronic circuit board located under the dashboard.

IMPORTANT *Never use hose nozzles or harsh detergents to clean the bodywork or the engine!*

When washing the inside of the cutting deck and the collector channel, the machine must be on firm ground with:

- the grass-catcher or discharge guard fitted;
- the operator seated;
- the engine running;
- the transmission in neutral;
- the blades engaged.

Connect a water hose to each of the pipe fittings one at a time and run water through each one for a few minutes, with the blades moving.

When washing, the cutting deck should be lowered right down. Take off the grass-catcher, empty and rinse it, and then put it in a position where it can dry quickly

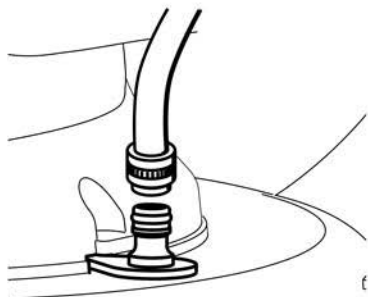

5.4.10 Storage and inactivity for long periods

If you intend not to use the machine for a long period (more than 1 month), disconnect the battery cables and follow the instructions in the engine instruction manual.

Empty the fuel tank by disconnecting the tube situated at the inlet of the fuel filter and follow the instructions in the engine manual

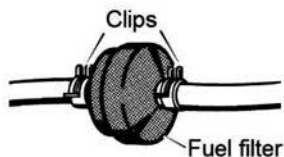

▲ WARNING! *Carefully remove any dry grass cuttings which may have collected around the engine or silencer to prevent their catching fire the next time the machine is used!*

Put the machine away in a dry, sheltered place and preferably covered with a cloth.

IMPORTANT *The battery must be kept in a cool and dry place. Before a long storage period (more than 1 month), always charge the battery, and then recharge before using again.*

The next time the machine is used, check that there are no fuel leaks from the tubes, fuel stopcock or carburetor.

5.4.11 Card protection device

The electronic circuit board has a self-resetting protector which breaks the circuit if there is a fault in the electrical system. It results in the stopping of the engine and the switching off of the lamp.

HOW TO USE THE MACHINE

The circuit automatically resets after a few seconds but the cause of the fault should be ascertained and dealt with to avoid reactivating the protection device

IMPORTANT

To avoid activating the protection device:

- do not invert the leads on the battery terminals;
- do not use the machine without its battery or damage may be caused to the charging regulator;
- be careful not to cause short-circuits.

5.4.12 Summary of main steps to follow when using the machine

| To... | You must... |
|--|---|
| Start the engine (5.4.1) | Open the fuel stopcock, ensure that all the conditions allowing starting are met, and then turn the key |
| Go forward (5.4.2) | push the pedal right down, engage the gear and then gradually release the pedal. |
| Brake or stop (5.4.3) | Reduce the engine speed and press the brake pedal. |
| Reverse (5.4.4) | Stop the machine; put into neutral, push the pedal right down, engage reverse, and then gradually release the pedal. |
| Cut the grass (5.4.5) | Fit the discharge guard; apply the throttle; engage the blades; adjust the cutting height, push the pedal right down, engage the gear and then gradually release the pedal. |
| Unblock the collector channel (5.4.6) | Stop moving forwards, disengage the blades and turn off the engine. Open the discharge guard and clean the collector channel.. |
| Finish mowing (5.4.7) | Disengage the blades and reduce the engine speed. |
| Stop the engine (5.4.8) | Reduce the engine speed, wait a few seconds, turn the key and close the fuel stopcock. |
| Store the machine (5.4.10) | Engage the parking brake, remove the key and, if necessary, wash the machine, the inside of the cutting deck, the collector channel and the grass-catcher |

5.5 USING ON SLOPING GROUND

Only mow on slopes with gradients up to the maximum already mentioned.

Lawns on a slope have to be mowed moving up and down and never across them. When changing direction, take great care that the wheels facing up the slope do not hit any obstacles (such as stones, branches, roots, etc.) that may cause the machine to slide sideways, tip over or make you lose control



▲ DANGER! *REDUCE SPEED BEFORE ANY CHANGE OF DIRECTION ON SLOPES, and always apply the parking brake before leaving the machine at a standstill and unattended.*

▲ WARNING! *Start moving forwards very carefully on sloping ground to prevent the risk of tipping over. Reduce the forward speed before going on a slope, particularly downhill.*

▲ DANGER! *Never use reverse to reduce speed going downhill: this could cause you to lose control of the vehicle, especially on slippery ground.*

Go down slopes without touching the pedal (see 4.9) to take advantage of the braking effect of the hydrostatic drive when the transmission is not engaged.

5.6 TRANSPORTING

▲ WARNING! *If the machine is transported on a truck or trailer, use suitable equipment for lifting and enough people for the weight involved and the type of lifting system used. The machine must never be lifted by rope and tackle. During transport, close the fuel stopcock, lower the cutting deck, apply the parking brake and fasten the machine securely with ropes or chains to the hauling device.*

5.7 LAWN MAINTENANCE

1. To keep a lawn green, soft and attractive, it should be cut regularly without damaging the grass. A lawn can be composed of different types of grass. If the lawn is cut frequently, grass and roots grow more vigorously, forming a solid grassy bed. If the lawn is cut less frequently, higher grass and weeds start growing (plus daisies and clovers, etc.).

2. It is always better to cut the grass when dry.

3. The blades must be in good condition and well sharpened so that the grass is cut straight without a ragged edge that leads to yellowing at the ends.

4. The engine must run at full speed, both to ensure a sharp cut of the grass and to get the necessary thrust to push the cuttings through the collector channel.

5. The frequency of mowing should be in relation to the rate of growth of the grass. The grass should not be left to grow too much between one cut and the next.

6. During hot and dry periods, the grass should be cut a little higher to prevent the ground from drying out.

HOW TO USE THE MACHINE

7. The best height of the grass on a well-kept lawn is approx. 4-5 cm. With one cut, you do not need to remove more than a third of the total height. If the grass is very tall, it should be cut twice in a twenty-four-hour period – the first time with the blades at maximum height, possibly reducing the cutting width, and the second cut at the desired height.

8. When you mow large areas, start by turning to the right so that the cut grass will discharge away from shrubs, fences, drive-ways, etc. After one or two rounds, mow in the opposite direction making left turns until finished

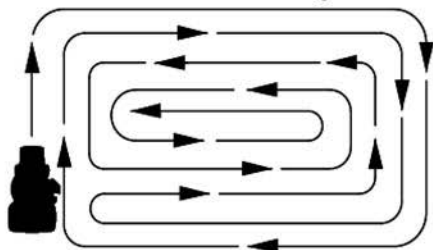

9. The appearance of the lawn will improve if you alternate cutting in both directions.

10. If the collector system tends to get blocked with grass, you should reduce the forward speed as it may be too high for the condition of the grass. If the problem persists, the probable causes are either badly sharpened blades or deformed wings.

11. Be very careful when mowing near bushes or curbs as these could distort the horizontal position of the cutting deck and damage its edge as well as the blades

6. MAINTENANCE

6.1 SAFETY RECOMMENDATIONS

▲ WARNING! *Before cleaning or doing maintenance work, take out the ignition key and read the relevant instructions. Wear adequate clothing and work gloves whenever your hands are at risk.*

▲ WARNING! *Never use the machine with worn or damaged parts. Faulty or worn-out parts must always be replaced and not repaired. Only use original spare parts: Parts that are not of the same quality can damage the equipment and affect your safety and that of others*

IMPORTANT *Never dispose of used oil, fuel, batteries or other pollutants in unauthorized places!*

6.2 SCHEDULED MAINTENANCE

6.2.1 Programmed maintenance

| Operation | Hours | Completed (Date or Time) | | | | | | |
|---|-------|--------------------------|--|--|--|--|--|--|
| 1. MACHINE | | | | | | | | |
| 1.1 Check of fastening and sharpness of blades | 25 | | | | | | | |
| 1.2 Blade replacement | 100 | | | | | | | |
| 1.3 Transmission belt check | 25 | | | | | | | |
| 1.4 Transmission belt replacement ²⁾ | – | | | | | | | |
| 1.5 Blade belt check | 25 | | | | | | | |
| 1.6 Blade belt replacement ²⁾ | – | | | | | | | |
| 1.7 Drive adjustment and check | 10 | | | | | | | |
| 1.8 Blade brake and engagement check | 10 | | | | | | | |
| 1.9 Bolt and screw check | 25 | | | | | | | |
| 1.10 General lubrication ³⁾ | 25 | | | | | | | |
| 2. ENGINE ¹⁾ | | | | | | | | |
| 2.1 Engine oil change | | | | | | | | |
| 2.2 Air filter cleaning and check | | | | | | | | |
| 2.3 Air filter replacement | | | | | | | | |
| 2.4 Fuel filter check | | | | | | | | |
| 2.5 Fuel filter replacement | | | | | | | | |
| 2.6 Spark plug contacts check and cleaning | | | | | | | | |
| 2.7 Spark plug replacement | | | | | | | | |

1) See the engine manual for the full list and frequency.

2) At the first signs of wear, contact your dealer to replace the part.

3) General lubrication of all joints should also be carried out whenever the

machine is to be left unused for a long period.

The above table is there to help you maintain your machine's safety and performance. It shows the main maintenance and lubrication operations and their frequency. To the right of each item, there is a box where you can write the date or after how many operating hours the work was carried out.

▲ WARNING!

All checks, adjustments and replacements not described in chapters 6.3 and 6.4 of this manual must be carried out by your Dealer or a specialized Service Centre. Both have the necessary knowledge and tools to ensure that the work is carried out correctly without affecting the safety of the machine.

6.2.2 Summary of main situations where servicing operation may be required

| Whenever... | You will need to... |
|---|-------------------------|
| The blades vibrate | Contact Your Dealer |
| The blades tear the grass and the lawn becomes yellow | Contact Your Dealer |
| The cut is uneven | Align the cutting deck. |
| The blades engage in an abnormal way | Contact Your Dealer |
| The machine does not brake | Contact Your Dealer |
| Forward movement is erratic | Contact Your Dealer |

6.2.3 Engine

IMPORTANT

Follow all the instructions in the engine manual.

To empty the engine oil, unscrew the oil plug when refitting the plug, make sure the seal is positioned correctly

6.2.4 Battery

The battery must be carefully maintained to ensure long life. The machine battery must always be charged:

- before using the machine for the first time after purchase;
- before leaving the machine disused for a long period;
- before starting up the machine after a long period of disuse.

Carefully read and observe the battery recharging instructions in the booklet provided with the battery. Failure in following the instructions or in charging the battery could permanently damage the battery cells.

A flat battery **must** be recharged as soon as possible.

IMPORTANT Recharging must be done using a battery charger at **constant voltage**. Other recharging systems can irreversibly damage the battery

6.3 CHECKS AND ADJUSTMENTS

6.3.1 Cutting deck alignment

The cutting deck should be properly set to obtain a good cut.

NOTE

To achieve good results from cutting, the front part should always be 5-6mm lower than the rear.

–Put the machine onto a flat surface and check the tire pressures;

– Put 30 mm blocks under the front edge of the deck and 35 mm blocks under the rear edge and then put the lifting lever into position «2»;

– Adjust the left front adjuster rod, right adjuster rod and right rear adjuster rod keep the deck in touch with the blocks;

–Adjust the lift rod keep the deck in touch with the blocks.

In the flat lawn, if need, you can change the position of wheel to obtain a lower cut.

IMPORTANT In the heave lawn, you must set the wheel in the hole «A».

In case of any doubts, do not hesitate to contact your retailer.

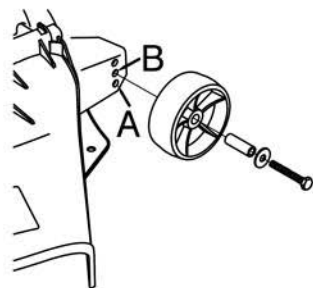
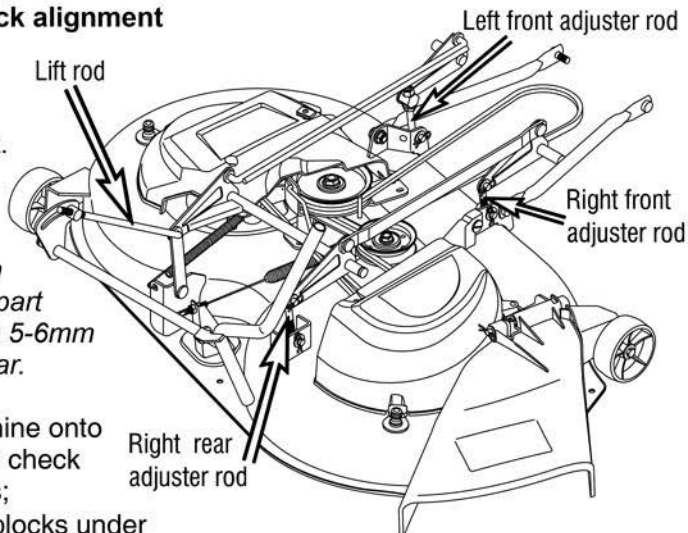

6.3.2 Cutting blades disengage

IMPORTANT When you move the blade rotation engagement lever to the **DISENGAGE** position, all movement will stop within five seconds if the adjustment is correct. In case of any doubts, do not hesitate to contact your retailer.

MAINTENANCE

move the blade rotation engagement lever to the **DISENGAGE** position, adjust the cut drive cable to propriety loose by the adjuster nut, then move the blade rotation engagement lever to the **ENGAGE** position, check the tension of the blade drive spring.

After you operate with a new mower drive belt for several hours, check the tension of the blade drive spring.

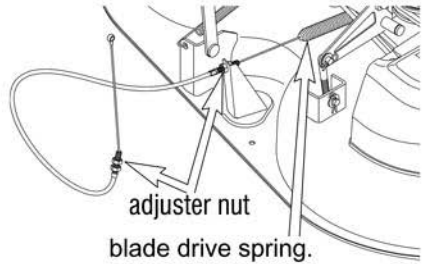

▲ WARNING! *If you cannot correctly adjust the drive brake, replace the brake pads. Correct replacement parts and assistance are available from an authorized service center.*

▲ WARNING! *Before you make an inspection, adjustment, or repair to the unit, disconnect the wire to the spark plug. Remove the wire from the spark plug to prevent the engine from starting by accident.*

6.4 DISMANTLING AND REPLACEMENT

6.4.1 Replacing wheels

Stop the machine on flat ground and put a block under a load-bearing part of the frame on the side that the wheel is to be changed.

The wheels are held by a snap ring which can be eased off with a screwdriver.

NOTE

If you have to replace one or both rear wheels, they have the same diameter, and check that cutting deck is horizontal to prevent an uneven cut. You must make sure the key and washer are securely lodged in place.

IMPORTANT

Before remounting the wheel, apply grease to the axle. Put the snap ring and supporting washer back in place.

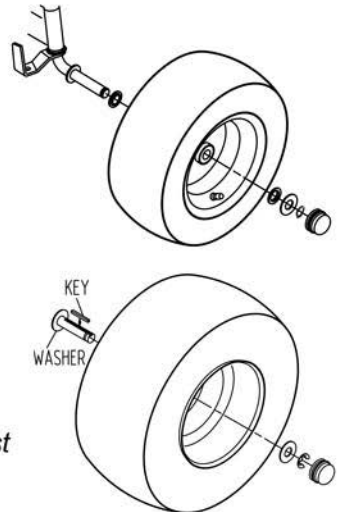

6.4.2 Replacing and repairing the tires

The tires are "Tubeless" and so all punctures must be repaired by a

tyre repairer following the procedures required for this kind of tyre.

6.4.3 Replacing the bulbs

The bulbs (12V18W) have a bayonet fitting and are installed in the bulb holder which can be taken out by turning it anticlockwise.

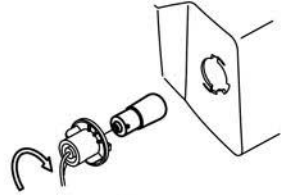

6.4.4 Replacing a fuse

The machine is fitted with 10A fuses. When it blows, the machine stops, the dashboard light switches off, and the battery gradually runs out, the machine will have problems starting.

Remove the fuse and replace with a same type fuse.

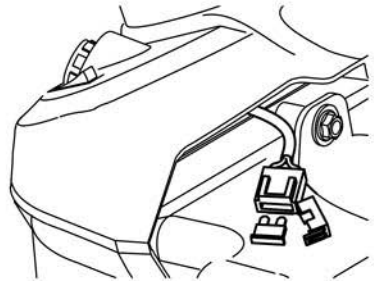

IMPORTANT A blown fuse must always be replaced by one of the same type and ampere rating, and never with one of another rating.

6.4.5 Dismantling, replacing and remounting the blades

▲ WARNING! Always wear work gloves when handling the blades. Before you inspect or remove the blade, stop the engine and disconnect the wire to the spark plug.

▲ WARNING! Damaged or bent blades must always be replaced; never try to repair them! ALWAYS USE ORIGINAL BLADES! Make sure the blades are correctly balanced. Make sure you put them back in the right place by referring to the code and rotate direction stamped on the outside of each blade.

1. Dismantling

Loosen anticlockwise the screw.

2. Original spare parts

Only the following blades can be used on this machine:

98.41.101

3. Remounting

Make sure the printed code on the

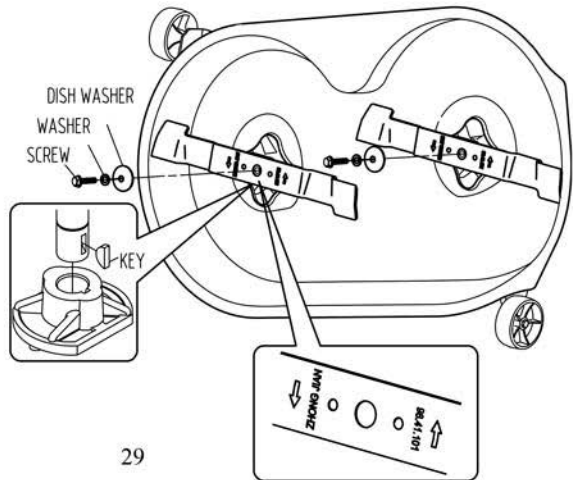

blade to face the operator who remounted the blade.

Check that the concave part of the disc washer presses against the blade.

Remount the shaft hubs, making sure the key are securely lodged in place.

4. Tightening the screws

Tightening clockwise with a torque wrench calibrated to 40~45N.m.

6.4.6 Replacing the belt

The belt replacement must be carried out at a Licensed Service Centre. Replace the belts as soon as they show obvious sign of wear!

▲ WARNING!

ALWAYS USE GENUINE REPLACEMENT BELTS!

6.5 LUBRICATION

Apply grease with a injector to the areas shown. apply two or three shots of grease, and wipe off excess grease.

Lubricate the areas shown with engine oil. wipe the area clean, apply a few drops of oil, then wipe up drips or spills.

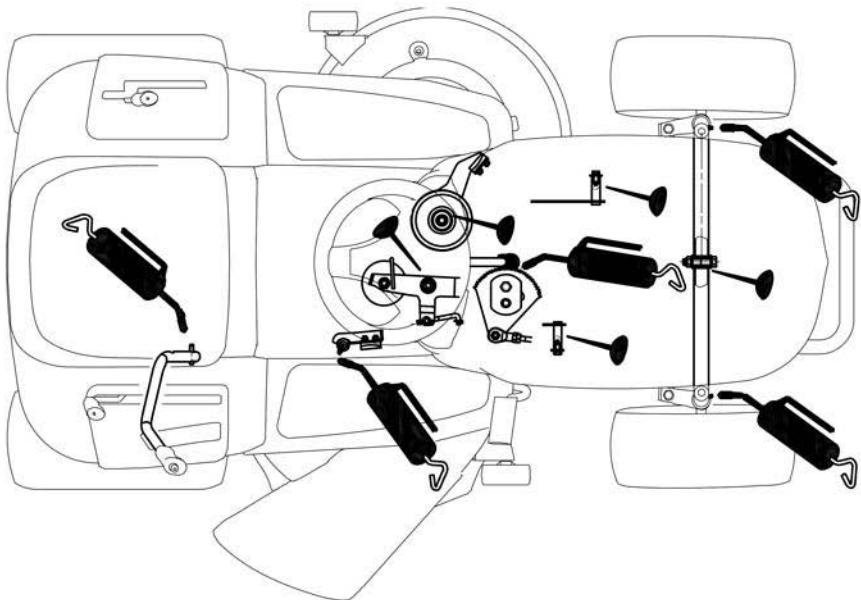

IMPORTANT

Do not dirty the belt or brake shoe or tire with the grease or oil, oil or grease will damage them.

7. SPECIFICATIONS

7.1 TECHNICAL DATA TABLE – DUELT38-6

| | | | |
|---|---|--|--|
| Model | DUELT38-6 | | |
| Rated power: | 8.8kW | | |
| Max. engine speed: | 2800min⁻¹ | | |
| Blade: | Type: 98.41.101; Length: 493 mm | | |
| Sound pressure level at the operator (EN 836+A4) | L_{pA}: 88.6 dB(A), K_{pA}: 3 dB(A) | | |
| Guaranteed sound power level (2000/14/EC) | L_{WA}: 100 dB(A), K_{WA}: 0.58 dB(A) | | |
| Vibration (EN 836+A4) | a_h: 11.53 m/s², K_h: 1.5 m/s² | | |

| | | | |
|---|---------------------------|---------------------|--------------------------|
| Cutting diameter | 98 cm | | |
| Blade screw tightening torque | 40–45 Nm | | |
| Cutting height (on 7 levels) | 30 – 90 mm | | |
| Front wheels | 15 x 6.00-6 | | |
| Rear wheels | 18 x 8.50-8 | | |
| Front wheel inflation pressure | 1.0 bar | | |
| Rear wheel inflation pressure | 1.2bar | | |
| Electrical system | 12V | | |
| Battery | 18Ah | | |
| Forward movement speed (theoretic with engine revs 2800 1/min) | | | |
| - in forward | from 0 to 8.8 km/h | - in reverse | from 0 to 4.5km/h |
| Net weight | 165 kg | | |
| Gross weight | 200 kg | | |

SPECIFICATIONS

7.1 TECHNICAL DATA TABLE – DUELT42-5

| | | | | |
|---|--|--|--|--|
| Model | DUELT42-5 | | | |
| Rated power: | 9.2 kW | | | |
| Max. engine speed: | 2800min ⁻¹ | | | |
| Blade: | Type: 108.41.101; Length: 542 mm | | | |
| Sound pressure level at the operator (EN 836+A4) | L _{pA} : 88.6 dB(A), K _{pA} : 3 dB(A) | | | |
| Guaranteed sound power level (2000/14/EC) | L _{WA} : 100 dB(A), K _{WA} : 0.58 dB(A) | | | |
| Vibration (EN 836+A4) | a _h : 11.53 m/s ² , K _h : 1.5 m/s ² | | | |

| | | | |
|---|--------------------|---------------------|-------------------|
| Cutting diameter | 108 cm | | |
| Blade screw tightening torque | 40–45 Nm | | |
| Cutting height (on 7 levels) | 30 – 90 mm | | |
| Front wheels | 15 x 6.00-6 | | |
| Rear wheels | 18 x 8.50-8 | | |
| Front wheel inflation pressure | 1.0 bar | | |
| Rear wheel inflation pressure | 1.2bar | | |
| Electrical system | 12V | | |
| Battery | 18Ah | | |
| Forward movement speed (theoretic with engine revs 2800 1/min) | | | |
| - in forward | from 0 to 8.8 km/h | - in reverse | from 0 to 4.5km/h |
| Net weight | 170 kg | | |
| Gross weight | 210 kg | | |

7.2 Machine Dimensions

DUEL38-6

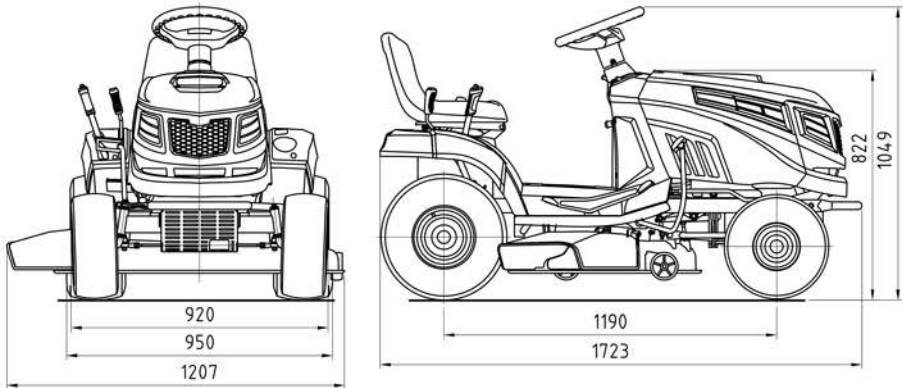

DUEL42-5

