

DUCAR

Diagramme de pièces *Parts diagram*



Le modèle peut différer légèrement de la photo / *The model may differ slightly from the picture*

DP50

Pompe à eau *Water pump*

DP50

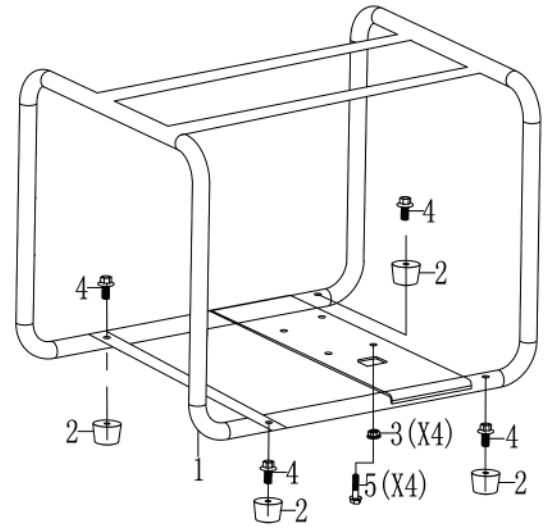
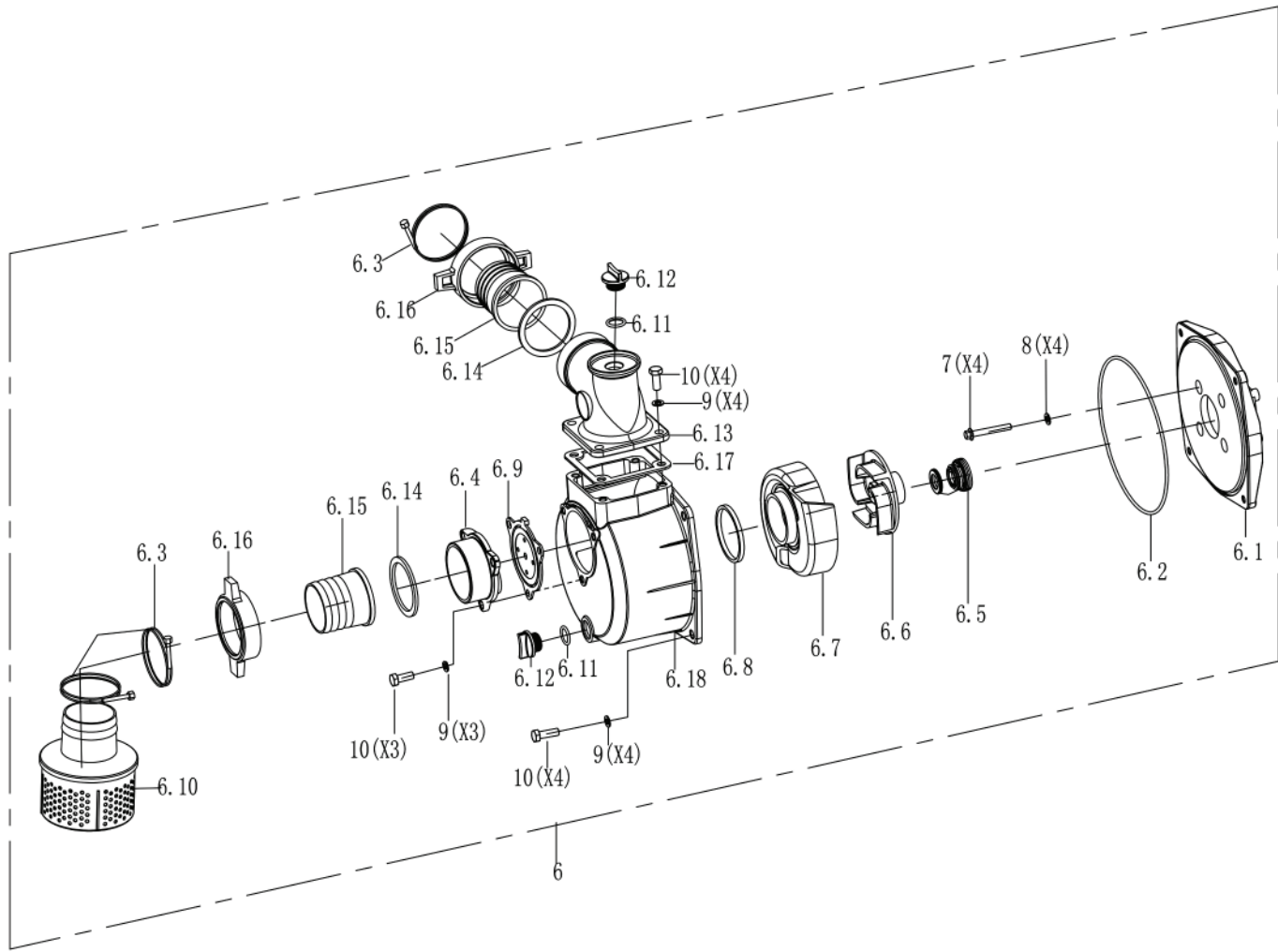

Spare parts for the DP50 gasoline water pump			
NO.	Code	Description	Qty
1	808405-010	FRAME	1
2	531112	RUBBER DAMPING BRACKET	4
3	90018	NUT M8	4
4	91325	BOLT M6X12	4
5	91348	BOLT M8X35	4
6	801011	WATER PUMP ASSEMBLY	1
6,1	7232	WATER PUMP COVER	1
6,2	7212	PACKING RING,WATER PUMP	1
6,3	7223	CLIP	3
6,4	7205	INLET	1
6,5	7209	PACKING RING,WATER PUMP	1
6,6	7230	IMPELLER	1
6,7	7203	IMPELLER COVER	1
6,8	7215	PACKING RING, IMPELLER COVER	1
6,9	7221	VALVE,SUCTION PORT	1
6,10	7225	STRAINER	1
6,11	7219	PLUG SEAL	2
6,12	7220	PLUG	2
6,13	7206	OUTLET	1
6,14	7222	PACKING RING,WATER PUMP	2
6,15	7208	INLET/OUTLET PIPE	2
6,16	7207	WING NUT,HOSE FITTING	2
6,17	7213	PACKING, WATER PUMP OUTLET	1
6,18	7204	WATER PUMP HOUSING	1
7	91359	BOLT M8X60	4
8	94257	FLAT WASHER $\Phi 8 \times \Phi 16 \times 1.5$	4
9	94222	FLAT WASHER $\Phi 8$	11
10	91346	BOLT M8X20	11