

**INVERTER GENERATOR**  
**OPERATOR'S MANUAL**

**MODEL:**  
**D8600i**

ORIGINAL INSTRUCTIONS

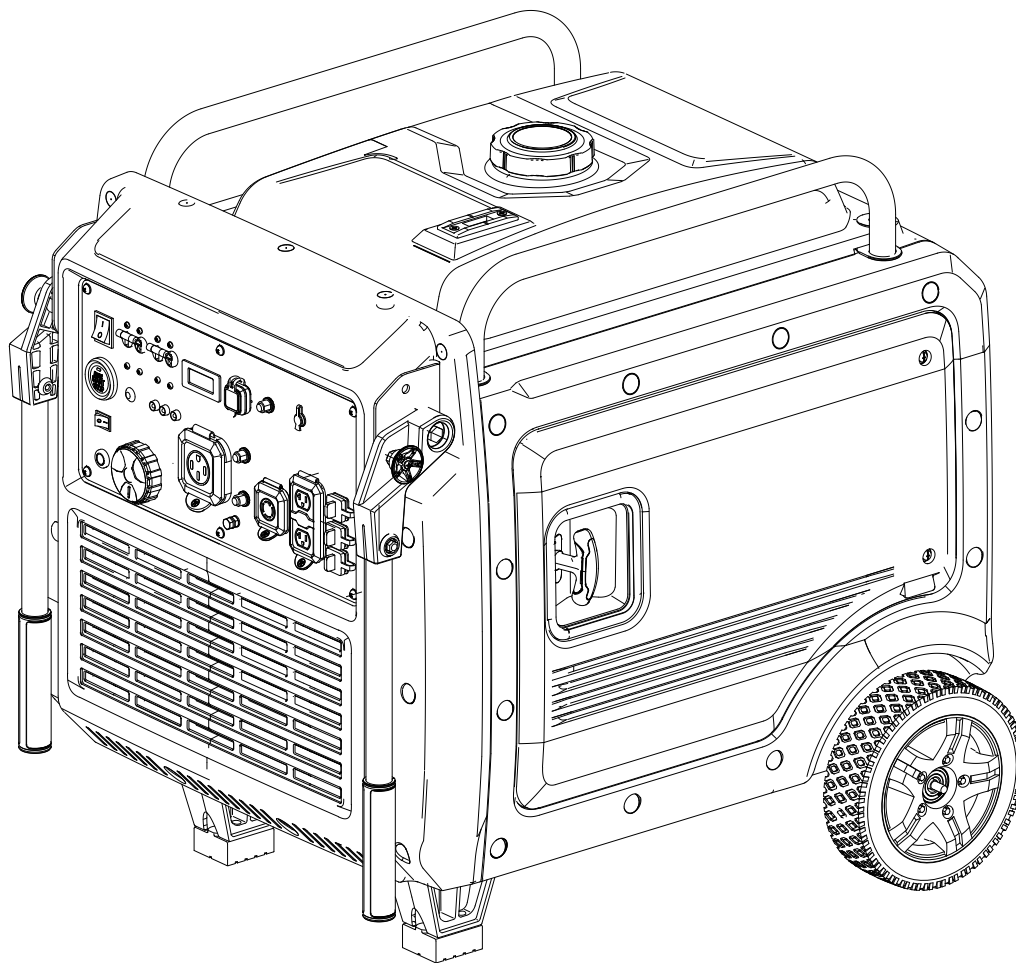

The picture is only for your reference

---

# TABLE OF CONTENTS

<b>Introduction</b> .....	<b>3</b>
Product Specifications.....	3
<b>Safety Rules</b> .....	<b>4</b>
Safety Symbols .....	4
Safety Instructions .....	4
<b>Features</b> .....	<b>8</b>
<b>Control Panel Functions</b> .....	<b>9</b>
Start knob.....	9
Indicator Lights.....	9
DC Circuit Breaker.....	10
Engine ECO Control.....	10
Parallel Outlets.....	10
Battery Switch.....	11
Push Button Start/Stop.....	11
Ground Terminal.....	11
<b>Assembly</b> .....	<b>12</b>
Connecting Generator to an Electrical System.....	12
Adding Fuel.....	13
Adding / Checking Engine Oil .....	13
<b>Operation</b> .....	<b>15</b>
Grounding the Generator .....	15
How to Start Engine.....	15
How to Stop Engine.....	17
How to Attach Electronic Devices.....	18
Charging a 12 Volt Battery.....	18
AC Parallel Operation.....	19
Don't Overload Generator.....	20
Wattage Reference Guide.....	20
<b>Maintenance</b> .....	<b>21</b>
Maintenance Schedule .....	21
Checking Spark Plug .....	22
Changing Oil .....	23
Air Filter.....	24
Checking Muffler and Spark Arrester.....	24
Fuel Filter .....	25
Storage .....	25
<b>Troubleshooting</b> .....	<b>27</b>
<b>Diagrams</b> .....	<b>28</b>

# INTRODUCTION

*Thank you for purchasing this superior quality portable generator. When operating and maintaining this product as instructed in this manual, your generator will give you many years of reliable service.*

## Product Specifications:

This generator is an engine-driven, revolving field, alternating current (AC) portable generator. It is designed to supply electrical power to operate tools, appliances, camping equipment, lighting, or serve as a back up power source during power outages.

## Generator specification

<b>Model</b>	D8600i
<b>Voltage</b>	120V/240V
<b>Frequency</b>	60Hz
<b>Power(COP)</b>	8.2kw
<b>Power(Max.)</b>	8.5kw
<b>USB Outlet</b>	5V/3.1A
<b>Parallel Outlet</b>	YES
<b>Engine type</b>	4 Stroke/ Single Cylinder/ OHV
<b>Displacement</b>	457CC
<b>Fuel tank capacity</b>	27L
<b>Engine Oil Capacity</b>	1.1L
<b>Starting Type</b>	Recoil start/E-start/Remote start/One push start
<b>Battery</b>	9Ah
<b>External dimensions (mm)</b>	764×667×731
<b>Net weight</b>	95kg
<b>7 meters of noise</b>	68dBA

**The rated power output of the generator, the following standard reference conditions shall be used**

- **Total barometric pressure:** 100kPa
- **Air ambient temperature:** 298K (25°C)
- **Relative humidity:** 30%
- **Altitude:** 0m

# SAFETY RULES









## Safety Symbols



Indicates a potentially hazardous situation which could result in serious injury or death if not avoided.



Indicates a potentially hazardous situation which could result in damage to equipment or property.

Caution	Read the operator's instruction manual before use	Wear noise protection
		
Carbon monoxide (CO) danger	Fire hazard	Risk of explosion
		
Electrical hazard	Risk of being burnt	Lifting hazard
		

## Safety Instructions

The manufacturer cannot anticipate every possible hazardous circumstance that the user may encounter. Therefore, the warnings in this manual, on tags, and on affixed decals are not all-inclusive. To avoid accidents, the user must understand and follow all manual instruction and use common sense.



**Read and understand this manual in its entirety before operating. Improper use of this generator could result in serious injury or death.**



**Engine exhaust contains chemicals that lead to cause cancer and birth defects.**

- Always wash hands after handling generator



**Fuel is combustible and easily ignited. Do not refuel during operation. Do not refuel while smoking or near naked flames. Do not spill fuel.**

# SAFETY RULES



**WARNING**



**Exhaust gas is poisonous; do not operate in an unventilated area**

- Using a generator indoors **CAN KILL YOU IN MINUTES!**
- Carbon monoxide gas is a poisonous, odorless gas that can cause headache, confusion, fatigue, nausea, fainting, sickness, seizures, or death. If you start to experience any of these symptoms, **IMMEDIATELY** get fresh air and seek medical attention.
- Never use indoors, in a covered area, or in a confined space, even if doors and windows are open.
- Install a battery operated carbon monoxide alarm near bedrooms.
- Keep exhaust from this unit from entering a confined area through windows, doors, vents, or other openings.
- When working in areas where vapors could be inhaled, use a respirator mask according to all of its instructions.



**WARNING**

**Never exceed generator's wattage / amperage capacity. This could damage the generator and / or connected electrical devices.**

- Check operating voltage and frequency requirements of all electrical devices prior to plugging them into the generator.



**WARNING**

**Never start or stop engine with electrical devices plugged in to the receptacles. Failure to do so could damage the generator and / or electrical devices.**

- Always start the engine and left it stabilize before connecting any electronic devices.
- Disconnect all electronic devices before stopping the engine.



**WARNING**

**Starter and other moving parts can catch on clothing, jewelry, and hair.**

- Do not wear loose clothing or gloves.
- Remove jewelry or anything else that could be caught in moving parts.
- Tie back or wear protective head covering to contain long hair.



**WARNING**

**Pull cord recoils rapidly and pulls arm towards engine faster than you can let go which could result in injury.**

- To avoid the dangers of injury caused by the sudden change of rotation direction of the engine, pull starter cord slowly until resistance is felt, then pull rapidly.



**WARNING**



**Avoid contacting hot areas of this unit.**

- Use caution around the muffler, cylinder, and other engine parts as they can be extremely hot.
- Allow hot components to cool before touching.



**WARNING**

**The precautions to be respected by the user in the case of re-supply by generating sets of an installation, depending on existing protective measures in this installation and applicable regulations.**



**WARNING**

**The user that he shall conform to regulations of electrical safety applicable to the place where the generating sets are used.**

## SAFETY RULES



**This generator produces a very high voltage which could result in burns or electrocution causing serious injury or death.**

- Never handle the generator, electronic devices, or any cord while standing in water, while barefoot, or when hands or feet are wet.
- Always keep the generator dry. Never operate generator in rain or under wet conditions.
- Never plug electronic devices into generator having frayed, worn, or bare wires. Never touch bare wires or make contact with receptacles.
- Never permit a child or unqualified person to operate generator. Keep children a minimum of 10 feet away from the generator at all times.
- If using the generator for back up power, notify the utility company.
- If connecting generator to a building's electrical system for standby power, you must use a qualified electrician to install a transfer switch. Failure to isolate the generator from the power utility could result in serious injury or death to electric utility works.
- When using extension lines or mobile distribution networks the total length of lines for a cross section of 1.5 mm<sup>2</sup> should not exceed 60 m; for a cross section of 2.5 mm<sup>2</sup> this should not exceed 100 m.
- The generating set must not be connected to other power sources except with accessory advised by the manufacturer or other generators with the same model.
- Save these instructions. Refer to them frequently and use them to instruct others who may use this product. If you loan someone this product, loan these instructions also.
- Due to high mechanical stresses, only tough rubber sheathed flexible cable (in accordance with IEC60245-4) or the equivalent should be used.



**Generator Must be properly grounded to prevent electrocution.**

- Only operate generator on a level surface.
- Always connect the nut and ground terminal on the frame to an appropriate ground source.



**Only use this unit as intended or serious injury or death could result.**

- Do not bypass any safety device. Moving parts are covered with guards. Make sure all protective are in place.
- Never transport or make adjustments to this unit while it is running.
- Never insert objects through cooling slots.



**Never operate this unit if there are any broken or missing parts and only use replacement parts specifically designed for this unit.**

- Improper treatment of generator can damage the unit and shorten it's life.
- Always repair this unit as specified in this manual. If you have any questions contact your dealer or consult a qualified service center.
- Shut generator off if electrical if electrical output is missing, unit vibrates excessively or begins to smoke , spark or emit flames.

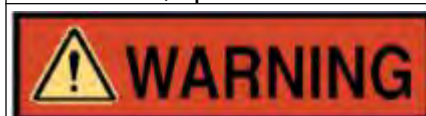

**To reduce the risk of serious injury, avoid attempting to lift the generator alone.**

# SAFETY RULES

## ⚠ DANGER

Using a generator indoors **CAN KILL YOU IN MINUTES**. Generator exhaust contains carbon monoxide. This is a poison you can't see or smell.



**NEVER** use inside a home or garage. **EVEN IF** doors and windows are open.



**ONLY** use **OUTSIDE** and far away from open windows, doors and vents.

## ⚠ DANGER

L'utilisation d'une génératrice à l'intérieur **PEUT VOUS TUER EN QUELQUE MINUTES**. Les émissions contiennent de l'oxyde de carbone. Ceci est un poison invisible et sans odeur.

Ne **JAMAIS** utiliser dans la maison ou garage. **MÊME SI** les portes ou fenêtres sont ouvertes.

Utilisez **SEULEMENT** à l'extérieur et loin des portes et fenêtres ouvertes, ainsi que des systèmes de ventilation.

## ⚠ WARNING/AVERTISSEMENT



**TOXIC FUMES HAZARD**. Running engines gives off carbon monoxide, an odourless poisonous gas that can cause nausea, fainting, or death. Do not start engine indoors or in an enclosed area, even if the windows and doors are open.

**DANGER TOXIQUE**. Faire fonctionner un moteur dégage de l'oxyde de carbone, un gaz inodore toxique qui peut provoquer la nausée, évanouissement ou la mort. Ne démarrer pas le moteur à l'intérieur ou dans une espace clos, même si les fenêtres et les portes sont ouvertes.

## ⚠ WARNING | AVERTISSEMENT

FOR ELECTRICAL EQUIPMENT ONLY  
 POUR MATERIEL ELECTRIQUE SEULEMENT  
 FOR USE IN A WEATHER PROTECTED WELL VENTILATED AREA  
 EMPLOYEZ UNIQUEMENT DANS UN EMPLACEMENT  
 A L'ABRI DES INTEMPERIES ET BIEN AERE  
 NEUTRAL FLOATING  
 NEUTRE FLOTTANT  
 DC SYSTEM FLOATING  
 DC RÉSEAU FLOTTANT

# FEATURES

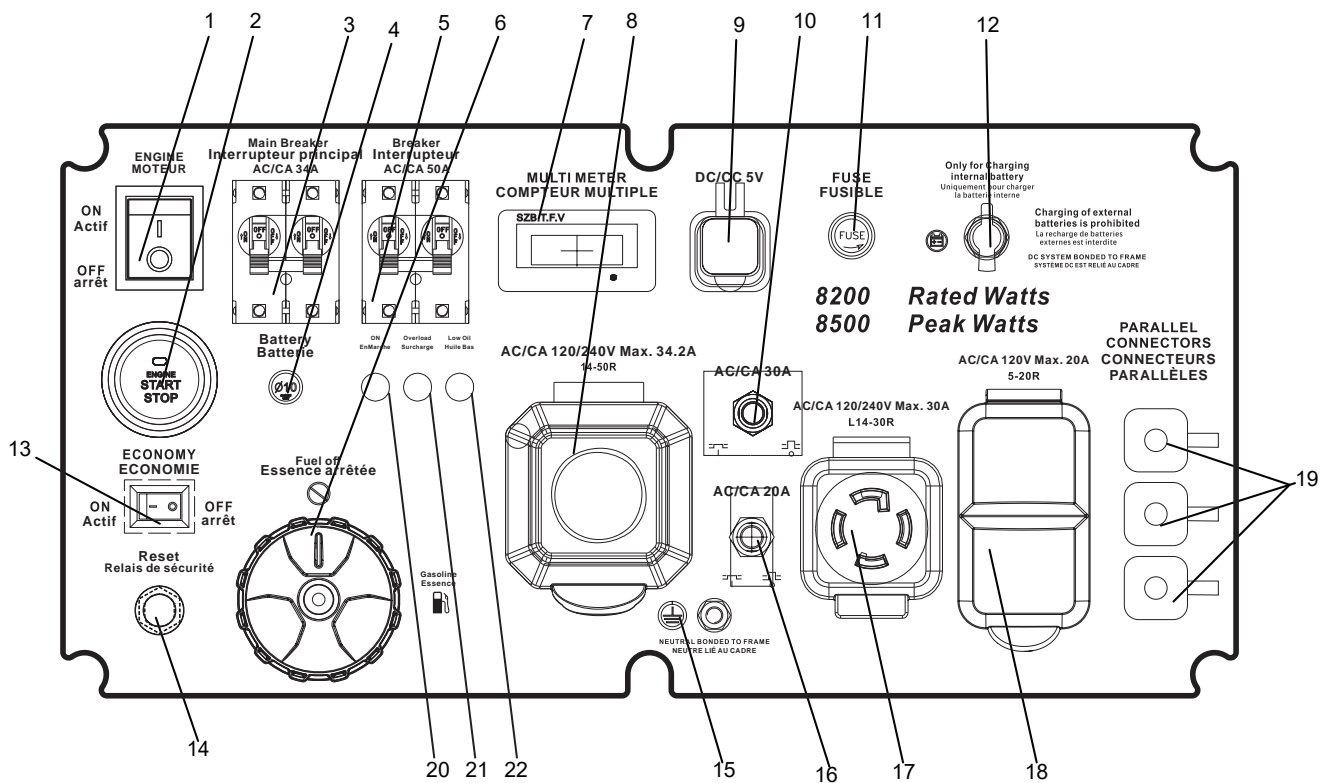
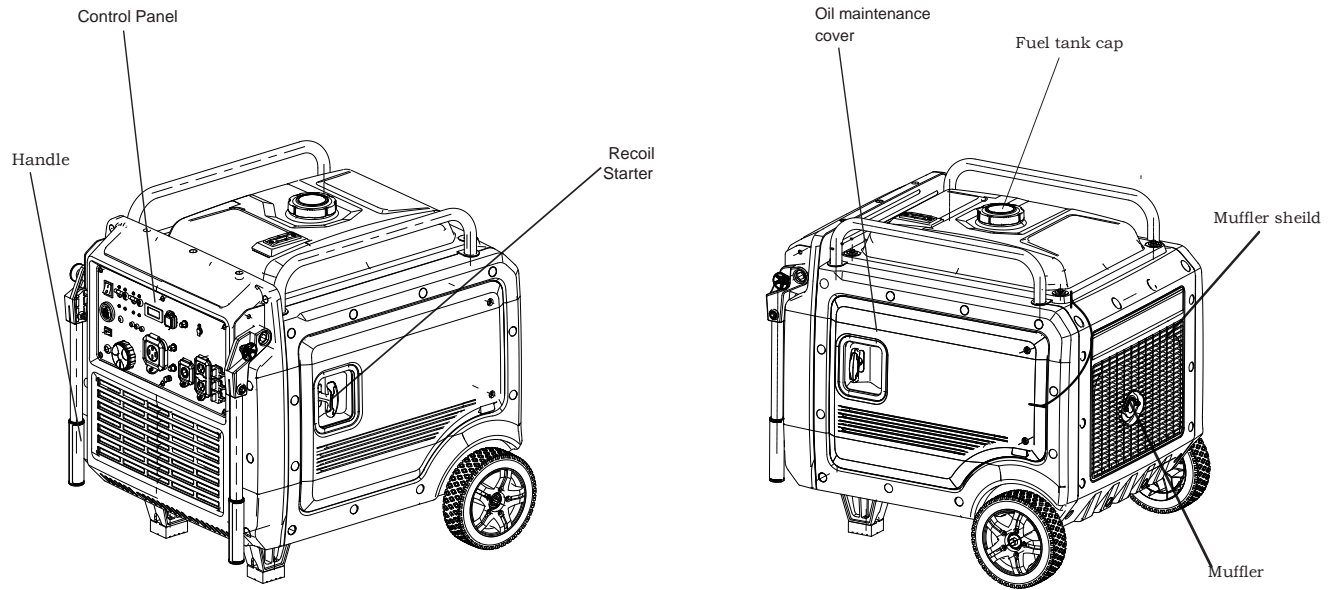

1. Battery switch
2. One click start switch
3. 34A main circuit breaker
4. Power indicator light
5. 50A circuit breaker
6. Fuel knob
7. Three in one digital display meter

8. American four hole industrial socket
9. USB
10. 30A bipolar circuit breaker
11. 3A fuse tube
12. Charging socket
13. Energy saving switch
14. Reset switch

15. Grounding terminal
16. 20A thermal protector
17. American four hole anti slip socket
18. American double socket
19. Grid connected sockets
20. Operation indicator light
21. Overload indicator light
22. Engine oil warning light



# CONTROL PANEL FUNCTIONS

## Start knob

When the start knob is in the Fuel off position, the engine cannot start.

When the start knob is in the Gasoline position and the fuel switch is in the open position, the engine can start.

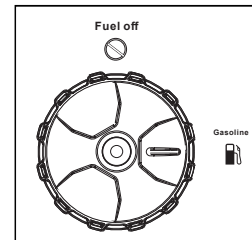
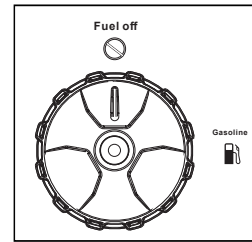

## On running Indicator light

When the generator is running normally, the "on" indicator light shows green, indicating that the generator is running normally.

## Overload indicator light

When the overload indicator light of the generator remains red when the load exceeds the specified current, the generator will implement overload protection to stop outputting external current. At this time, it is necessary to disconnect the electrical equipment and operate the "reset" button on the panel to reset the output. After opening the Breaker, the generator will output again to the outside world.

## Low oil level indicator light

When the "Low oil" indicator light shows red, it indicates that the engine oil is less than the set oil level and needs to be added. At this time, the engine cannot be started or used.



**Note:** When the generator is started, the overload indicator light may light up for a few seconds, which is a normal phenomenon.

# CONTROL PANEL FUNCTIONS

## DC Circuit Breaker

When the DC Circuit Breaker is in the “ON” position, the generator is able to supply power to connected electronic devices. When the DC Circuit Breaker is in the “OFF” position, the generator will no longer supply power. The DC Circuit Breaker automatically turns “OFF” when connecting electronic devices to the generator that exceed the generator’s rated output. If the DC Circuit Breaker turns off, reduce the load of connected electronic devices until the load is within the specified rated output. To re-establish power, return the DC Circuit Breaker back to the “ON” position. At the same time, the Reset switch needs to be reset.

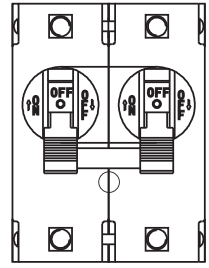

Reset



### CAUTION

If the DC Circuit Breaker turns off again, stop using the generator immediately and consult our dealers.

## Engine ECO Control

- When the Engine ECO switch is turned to the “ON” position, the economy control unit automatically determines the generator’s proper engine speed based on the connected electronic load. This results in superior fuel economy and reduces noise.
- When the ECO switch is turned to the “OFF” position, the engine runs at the rated speed of 3000 r/min.

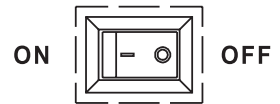

**Note:** The ECO switch must be turned to the “OFF” position when using electronic devices that require a large starting current, such as a compressor.

## Parallel Outlets

Located on the right side of the panel, the generator’s Parallel Outlets enable a user to run two D8600i generator’s simultaneously. This operation requires special cables. When operating parallel generators, the rated output is 14.7Kw . For cables and instructions consult a dealer for a PARALLEL OPERATION CABLE KIT.

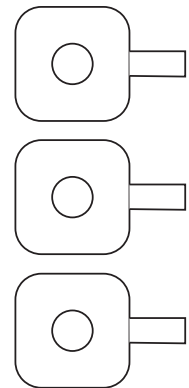

### WARNING

Never connect generators that are different models.

- Only connect this generator to another D8600i Standard Generator or D8600i Companion Generator
- Only use brands approved parallel operation cable kit to connect generators

# CONTROL PANEL FUNCTIONS

## Battery Switch

When starting the generator, turn on the switch and turn off the switch when not in use.

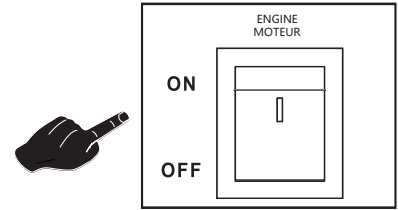

## Push Button Start/Stop

When the battery switch is on, long press to automatically start the generator, and press again to stop the generator.

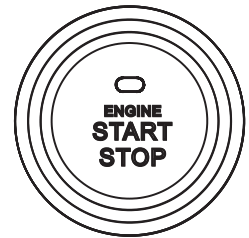

## Ground Terminal

The generator's ground terminal must always be used to connect the generator to a driven ground rod. Connect the ground terminal to the driven ground rod with a No 8 AWG (American Wire Gage) copper wire. The wire connects to the terminal between the lock washer and nut. Tighten the nut securely to ensure good connection. Grounding the generator protects you from electric shock that results from a build up of static electricity or undetected ground faults.

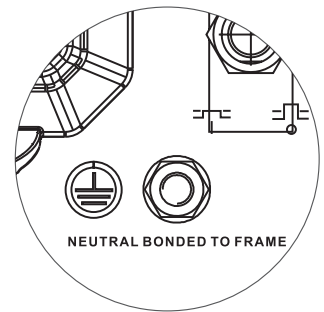

**WARNING**



**Generator must be properly grounded to prevent electrocution.**

- Only operate generator on a level surface.
- Always connect the nut and ground terminal on the frame to an appropriate ground source.

# ASSEMBLY

## Connecting Generator to an Electrical System

- If connecting generator to a building's electrical system for standby power, you must use a qualified electrician to install a transfer switch. The power from the generator must be isolated from the circuit breaker or alternative power source. The connection must comply with all electrical codes and applicable laws.

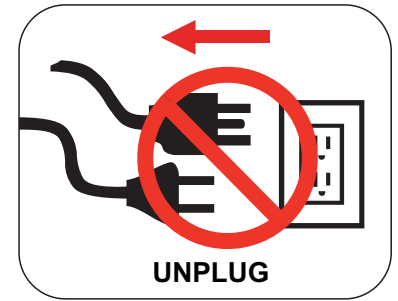

Never directly connect generator to a household power source.



**This generator produces a very high voltage which could result in burn or electrocution causing serious injury or death.**

- Never handle the generator, electronic devices, or any cord while standing in water, while barefoot, or when hands or feet are wet.
- Always keep the generator dry. Never operate generator in rain or under wet conditions.
- Never plug electronic devices into generator having frayed, worn, or bare wires. Never touch bare wires or make contact with receptacles.
- Never permit a child or unqualified person to operate generator. Keep children a minimum of 10 feet away from the generator at all times.
- If using the generator for back up power, notify the utility company.
- If connecting generator to a building's electrical system for standby power, you must use a qualified electrician to install a transfer switch. Failure to isolate the generator from the power utility could result in serious injury or death to electric utility works.
- When using extension lines or mobile distribution networks the total length of lines for a cross section of 1.5 mm<sup>2</sup> should not exceed 60 m; for a cross section of 2.5 mm<sup>2</sup> this should not exceed 100 m.
- The generating set must not be connected to other power sources except with accessory advised by the manufacturer or other generators with the same model.
- Save these instructions. Refer to them frequently and use them to instruct others who may use this product. If you loan someone this product, loan these instructions also.
- Due to high mechanical stresses, only tough rubber sheathed flexible cable (in accordance with IEC60245-4) or the equivalent should be used.

# ASSEMBLY

## Adding Fuel

- Set generator on a clean and level surface in an area that is well ventilated.
- Remove fuel cap.
- Insert a funnel into the fuel tank and carefully pour gasoline into the tank until fuel level reaches about 1 ½ inches below the top of the neck. Be careful not to overfill the tank to provide space for fuel expansion.
- Replace fuel cap and secure tightly.

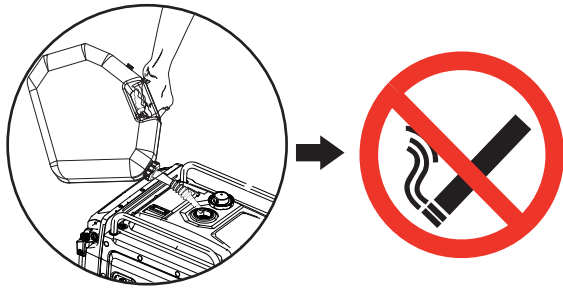
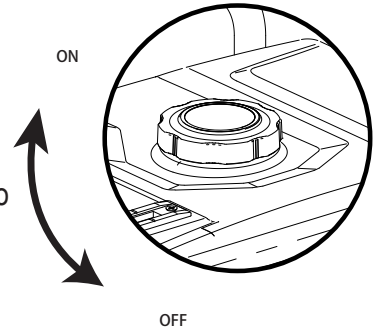

Do not smoke when adding fuel.

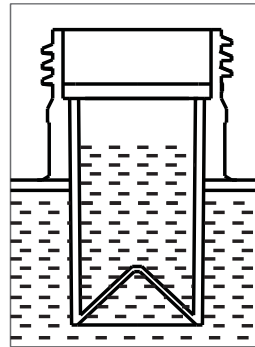

Do not to overfill the tank to provide space for fuel expansion.

## Adding / Checking Engine Oil (See fig 4)

The included, recommended oil type for typical use is 10W-30 engine oil. If running the generator in extreme temperatures, refer to the following chart.

Recommended Engine Oil Type									
			10W-30						
5W-30					10W-40				
5W-30 Synthetic									
	-20	0	20	40	60	80	100	120	
°C	-28.9	-17.8	-6.7	4.4	15.6	26.7	37.8	48.9	
Ambient Temperature									

# ASSEMBLY

**NOTE:** Check the engine oil level before each use or every 8 hours of operation.

- Turn the generator off and allow the engine to cool for at least five minutes.
- Place the generator on a level surface in a well-ventilated area.
- Remove the bolt.
- Remove the engine service cover.
- Clean the area around the oil dipstick.

## For initial oil fill:

- Slowly unscrew and remove the oil dipstick.
- Using the funnel, slowly pour the supplied engine oil into the oil fill hole. Stop frequently to make sure you do not overfill. **NOTE:** Your generator was functionally tested in the factory and may contain minimum residual oil. Additional oil is required to operate the unit. **Do not** overfill.

- Replace and tighten the oil dipstick.
- Install the engine service cover and tighten the bolts

## To check oil level:

- Slowly unscrew and remove the oil dipstick.
- Clean the dipstick and re-seat it inside the oil fill hole. Do not thread the dipstick.
- Remove the dipstick and verify that the oil level is within safe operating range.
- If the oil level is low, add recommended engine oil in-crementally and recheck until the level is within the safe operating range.
- Replace the oil dipstick and hand-tighten.
- Install the engine service cover and tighten the bolts.

**Recommended Oil:** SAE

**10W-30 Oil Capacity:** 1.1L

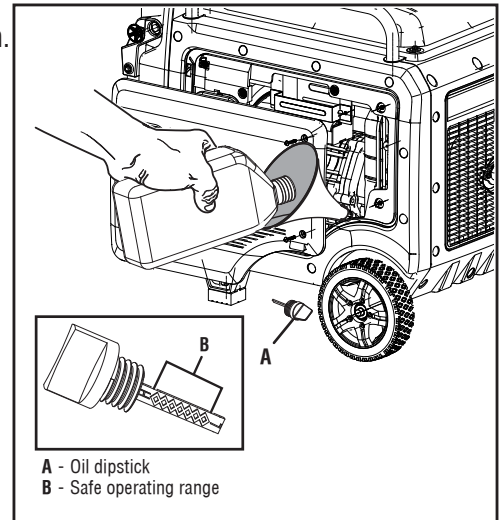

Generator has been shipped without engine oil. You must add oil before first operating this generator. Always check oil level before each operation.

# OPERATION

## Grounding the Generator

To avoid electrocution, this generator must be properly grounded prior to use. For instructions see Control Panel Functions pg. 11.

Standard Atmospheric Conditions Ambient Temperature: 77°F (25°C)

Barometric Pressure: 100kPa

Relative Humidity: 30%

Generator output will vary due to changes in temperature, altitude, and humidity. If the temperature, humidity, or altitude are higher than standard atmospheric conditions, the generator's output will be reduced. The load attached to the generator must therefore be reduced.

## How to Start Engine

### Generator start- Recoil status (D8600i)

- Place generator on a level surface. All electrical loads MUST be disconnected from generator.

Turn the knob switch to the Gasoline position.

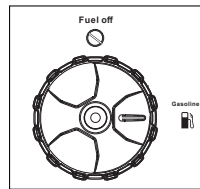

Turn the battery switch to the ON position

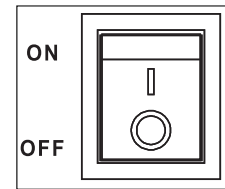

First gently pull the handle until the cable is hung tight, and then pull hard and quickly.

(Tip: When pulling the handle, the other hand should hold the generator to prevent it from falling)

- When the ambient temperature is lower than 0°C (32°F), the heating time is 3 min.
- When the ambient temperature is higher than 0°C, the heating time is 1 min.
- After running the above time, it is recommended that the energy saving

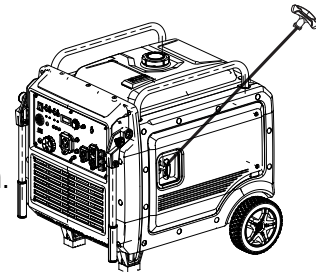

# OPERATION

## Generator start-One push start& Remote start (D8600i)

- Place generator on a level surface. All electrical loads MUST be disconnected from generator.
- Turn the knob switch to the Gasoline position.
- Turn the battery switch to the ON position.
- Long press the one button start switch, the engine will automatically start. If it start fails, the engine will automatically start twice.

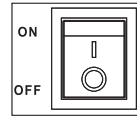
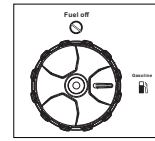

Remote Start: Push and hold the ON button on the remote start key fob for 0.5 second.

- When the battery is exhausted, start in the following way:

a. Open side panel;

b. Manually adjust the damper to close the damper;

c. Start by manual;

d. Assemble the baffle.

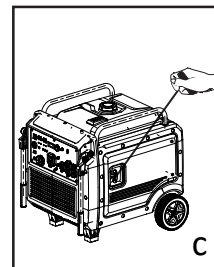
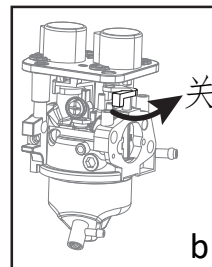
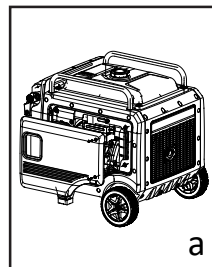

- A. When the ambient temperature is lower than 0°C (32°F), the heating time is 3 min.
- B. When the ambient temperature is higher than 0°C, the heating time is 1 min.
- C. After running the above time, it is recommended that the energy saving

## Connecting electrical equipment

Tip: When using the following devices, such as air compressors and sinking pumps, the energy saving mode must be turned off because of the large starting current required.



# OPERATION

## How to Stop Engine

### Generator stop -One push start & Remote start (D8600i)

•Disconnect any electronic device. All loads MUST be disconnect from the generator. Never start or stop the engine with electrical devices plugged in to the receptacles.

•a.One push off/One push start: Press the switch for 1 second and release it to turn off the generator set;



b. Remote off: Press the stop button of the remote control key for 1 second to release, and the generator set will be closed;



•Press the power switch to the "Off" position.

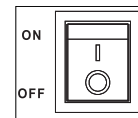

•Turn the fuel switch to the "Off" position.

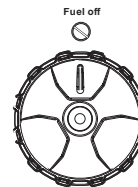

**WARNING** Never start or stop engine with electrical devices plugged in to the receptacles. Failure to do so could damage the generator and / or connected electrical devices.

- Always start the engine and let it stabilize before connecting any electronic devices.
- Disconnect all electronic devices before stopping the engine.

## Controller Reset

Long press the single start button for about 10 seconds, the indicator light starts flashing.

Then press any button on the remote control for about 1 second, the indicator light does not flash and becomes "on", indicating "matching successful".

## Meter Reading

The first meter reading is the current usage time and resets each time the machine is started.

**"V" is for voltage**

**"F" is for frequency**

**"T" is for total usage time**

# OPERATION

## How to Attach Electronic Devices

1. Before Starting generator
  - Make sure the generator is grounded (see page 11 for instructions).
  - Make sure the attached load is within the generator rated output and the receptacle's rated current.
  - Make sure all electrical cords and receptacles are in good condition.
  - Make sure all electronic devices are turned "OFF" before plugging them into the generator.
2. Start engine
3. If the attached load is small, turn the ECO switch to the "ON" position. For a larger load, or if attaching multiple electronic devices turn the ECO switch to the "OFF" position.
4. Make sure the green AC pilot indicator light is on.
5. When engine has stabilized, plug in and turn on first load. It is strongly recommended to plug in devices with the largest output first and the smallest output last to help prevent overloading the generator.
6. Allow generator output to stabilize (engine and attached devices run evenly) before plugging in the next load.

## Charging a 12 Volt Battery

This generator can be used to charge a 12 volt automotive or storage battery by taking the following steps:

Inspect fluid level of the battery cells. Add ONLY distilled water to any cell where fluid level is low. Never add tap water.

1. Use a wire brush to clean battery terminals if corroded.
2. Before connecting battery to generator, start generator engine. Make sure the DC Protector is turned to the "ON" position.
3. Securely connect the red cable clamp to the positive (+) battery terminal.
4. Securely connect the black cable clamp to the negative (-) battery terminal.
5. Turn the ESC switch to the "OFF" position to start battery charging.
6. Battery is considered fully charged when the gravity of its fluid is between 1.26 and 1.28 when measured by a hydrometer.

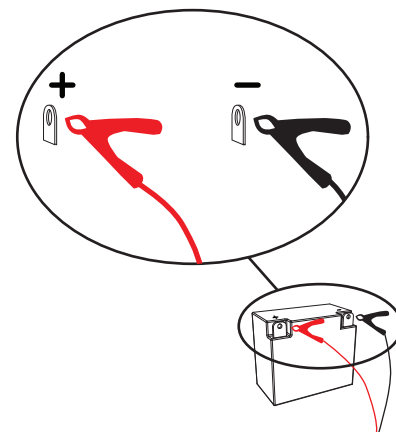

**Note:** It is strongly recommended to check the gravity level of the electrode at least once per hour with a hydrometer to prevent overcharging and to test the battery's condition. Be careful to follow the hydrometer manufacturer's instruction.



**WARNING**



**Battery electrolyte is poisonous and dangerous.**

- Do not disconnect battery clamps while charging. Batteries produce explosive gasses. Disconnecting the battery clamps while charging could spark and ignite.
- Do not charge battery in an enclosed area.
- Never smoke while charging the battery or operating or fueling this generator.
- Battery electrolyte contains sulfuric acid. Avoid contact with skin, eyes, and clothing. Always wear eye protection when charging battery.
- If battery acid contacts skin, flush with water immediately. If it contacts eyes, flush with water for 15 minutes and get immediate medical attention. For internal ingestion, drink large quantities of water or milk, followed by milk of magnesia, beaten egg, or vegetable oil. Contact a medical physician immediately.

# OPERATION

## AC Parallel Operation

The D8600i generator has two models that are compatible with each other (Standard and Companion). It is possible to connect two D8600i generators to each other, using a parallel cable kit.

- Connect PARALLEL OPERATION CABLES to two D8600i generators according to the instructions provided with the cable kit.
- Make sure the ECO switch is in the same position on both generators.
- All electronic devices should be turned “OFF” and disconnected from generators prior to starting generator engines.
- Start generator engines. Make sure the green output indicator light comes on for each generator.
- When engine has stabilized, plug in electronic device to AC receptacle and turn on first load.
- Allow generator output to stabilize (engine and attached devices run evenly) before plugging in the next load.

## Maximum Power in Parallel

**Operation: 14.7Kw Rated Power in Parallel**

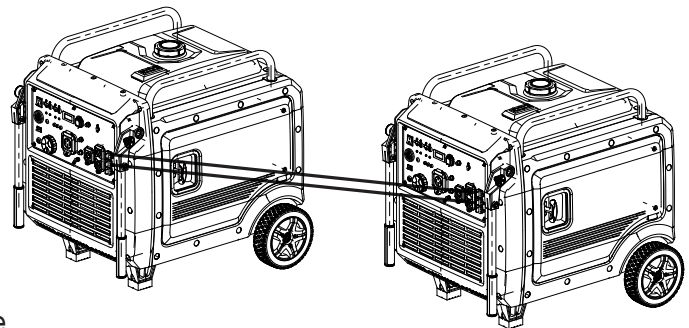

**Note:** It is strongly recommended to plug in devices with the largest output first and the smallest output last to help prevent overloading the generator.

**Note:** Most electronic devices require power beyond its rated wattage to start. This additional power is referred to as surge watts and usually lasts between 2-3 seconds. When an electronic device is started, the red overload indicator may come on. This is normal. If the light stays on disconnect all electronic devices and stop the engine. Refer to “Engine Overload Indicator Light” on page 9.



### **WARNING**

**Only connect electronic devices to the generator that are in good working order and do not exceed the rated power supply of the parallel generators or the desired receptacle.**

- A faulty appliance or power cord can create an electric shock. Do not use electronic devices that have a damaged cord or plug.
- If an appliance begins to operate abnormally, becomes sluggish, or stalls, turn off and disconnect appliance immediately. The appliance may have a fault or its rated load capacity exceeds the power supply of the generator.
- To avoid damage to generator or electronic device, do not connect a load to the generator if its electrical rating exceeds that of the receptacle.



### **WARNING**

**Never connect generators that are different models.**

- Only connect this generator to another D8600i Generator or DLG8600i Companion Generator
- Only use brands approved parallel operation cable kit to connect generators.
- The parallel cable must be removed if operating only one generator.
- Never disconnect or remove the parallel operation cable while generator is still running.

# OPERATION

## Don't Overload Generator

Make sure you can supply enough rated watts for all electronic devices connected to the generator. Rated watts refer to the power a generator must supply to keep a device running. Surge watts refer to the power a generator must supply to start an electronic device. This power surge for starting a device usually lasts between 2-3 seconds but this additional output must be taken into account when selecting the electronic devices you plan to attach to the generator. To prevent overloading the generator take the following steps:

1. Add up the total rated wattage of all electronic devices that will be connected to the generator simultaneously.
2. Estimate surge watts by adding the item(s) with the highest output (it is unnecessary to calculate the surge output for all devices as they should be connected one at a time).
3. Add the Surge Watts to the total Rated Watts in step 1. Keep total load within generator's power capacity.

## Wattage Reference Guide

(Wattages listed are just approximations. Check electronic device for actual wattage)

Essentials	Rated Watts	Surge Watts
75W Light Bulbs	75 each	75 each
18 CU Ft Refrigerator / Freezer	800	2200
Furnace Fan (1/3 HP)	800	2350
Sump Pump (1/3 HP)	1000	2000
Water Pump (1/3 HP)	1000	3000
<b>Heating/Cooling</b>		
Dehumidifier	650	800
Table Fan	800	2000
Electric Blanket	400	400
Space Heater	1800	1800
<b>Kitchen</b>		
Blender	300	900
Toaster (2 slice)	1000	1600
Coffee Maker	1500	1500
Electric Range (1 element)	1500	1500
Dishwasher	1500	3000
<b>Laundry Room</b>		
Iron	1200	1200
Washing Machine	1150	3400
Gas Clothes Dryer	700	2500

Bathroom	Rated Watts	Surge Watts
Hair Dryer	1250	0
Curling Iron	1500	0
<b>Family Room</b>		
X-Box or Play Station	40	0
AM/FM Radio	100	100
VCR	100	100
Color TV (27")	500	500
<b>Home Office</b>		
Fax Machine	65	0
Personal Computer (17" Monitor)	800	0
Laser Printer	950	0
Copy Machine	1600	0
<b>Power Tools</b>		
1000W Quartz Halogen Work Light	1000	0
Airless Sprayer (1/3 HP)	600	1200
Reciprocity Saw	960	0
Circular Saw (7 1/4")	1400	2300
Mitar Saw (10")	1800	1800
Table/Radial Arm Saw	2000	2000
Electric Drill (1/2 HP, 5.4 Amps)	600	900

# MAINTENANCE

Regular maintenance will extend the life of this generator and improve its performance. The warranty does not cover items that result from operator negligence, misuse, or abuse. To receive full value from the warranty, operator must maintain the generator as instructed in this manual, including proper storage.



**Before inspecting or servicing this machine, make sure the engine is off and no parts are moving. Disconnect the spark plug wire and move it away from the spark plug.**



**If you are unsure of how to perform a maintenance task, have the unit serviced by our dealers.**



**Only use our specified replacement parts.**

## Maintenance Schedule

### Pre-Operation Steps

Before starting the engine, perform the following pre-operation steps:

- Check the level of the engine oil and the fuel tank level. Check for any leakage.
- Check fuel hose for cracks or damage. Replace if necessary.
- Make sure the air filter is clean.
- Remove any debris that has collected on the generator and around the muffler and controls. Use a vacuum cleaner to pick up loose debris. If dirt is caked on, use a soft bristle brush.
- Inspect the work area for hazards.

### After Each Use

Follow the following procedure after each use:

- Shut off engine.
- Store unit in a clean and dry area.

<b>After First 5 Hours</b>	Change Oil.
<b>After 8 Hours or Daily</b>	Clean Debris.
	Check Engine Oil Level.
<b>6 Months (100 hr Use)</b>	Check and Clean Air Filter Element. (Service more often under wet or dusty conditions.)
	Change Engine Oil. (Service more often under dirty or dusty conditions.)
	Check Muffler Screen. Replace if necessary.
	Service Spark Plug.
	Inspect Muffler and Spark Arrester.
<b>12 Months (300 hr Use)</b>	Clean Fuel Filter. Replace if necessary.
	Check Crankcase Breather Hose for cracks or damage. Replace if necessary.
	De-carbonize cylinder head. See dealer.
	Check and adjust Valve Clearance. See dealer.
	Check all Fittings and Fasteners. See dealer.

# MAINTENANCE

## Checking Spark Plug

- Remove cap. Then remove spark plug cap.
- Disconnect the spark plug wire from the spark plug.
- Before removing the spark plug, clean the area around its base to prevent debris from entering the engine.
- Insert a spark plug socket wrench through the opening on the outside of the cover. Turn the wrench counterclockwise.
- Check for discoloration and clean carbon deposits off the electrode with a wire brush.
- Check the electrode gap and slowly adjust to 0.7 - 0.8mm (0.028-0.031 in) if necessary.
- Reinstall spark plug and tighten to Torque 20.0Nm (14.8ft-lb).
- If spark plug is worn replace only with an equivalent replacement part. Spark plug should be replaced annually.
- Reconnect spark plug wire.
- Replace spark plug cap, then replace cap.

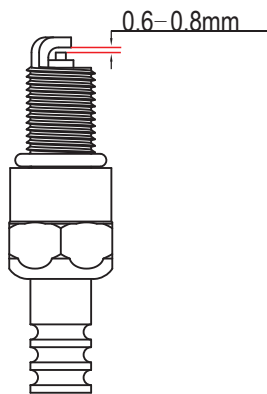

**Standard Spark Plug: F7TC/F7RT**

**Spark Plug Gap: 0.6 - 0.8mm (0.024-0.032in)**

**Spark Plug Torque: 25.0Nm (18.4lbf.ft)**

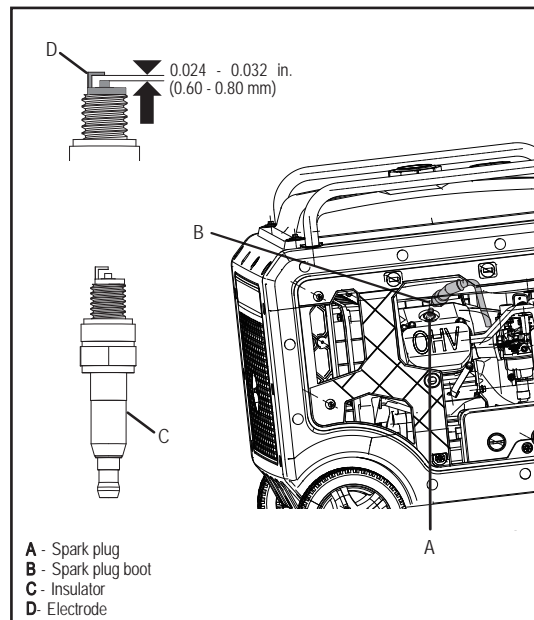

## Carburetor Adjustment

The carburetor is low emission and is equipped with a non-adjustable idle mixture valve. If adjustment is needed contact an authorized dealer.

# MAINTENANCE

## Changing Oil

- Place generator on a level surface.
- Run the generator for several minutes until the engine is warm. Turn off generator.
- Remove screws, then remove outer casing.
- Remove the crankcase dipstick.
- Place an oil pan underneath the engine. Tilt generator to collect used oil. Allow oil to drain completely.
- Return generator to a level surface.
- Carefully add 4-Cycle engine oil (SAE 10W-30) to empty reservoir until oil reaches the outer edge of the oil fill hole (Crankcase Dipstick hole).
- Use a clean rag to wipe up any spilled oil.
- Replace crankcase dipstick.
- Reinstall outer casing and tighten screws.

**Recommended Engine Oil:** SAE 10W-30

**Recommended Engine Oil Grade:** API Service SE type or higher quality of engine oil. **Engine Oil Quantity:** 1.1L

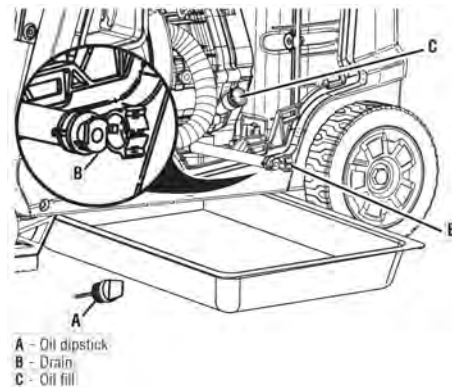
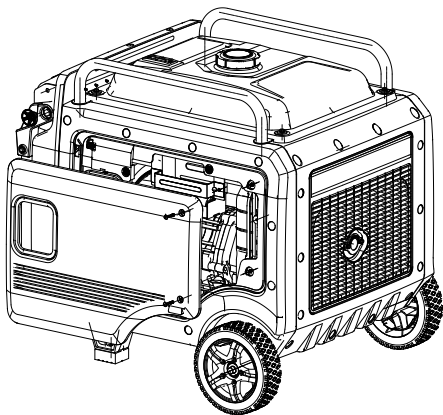

**CAUTION**

Do not tilt generator when adding oil. This could result in overfilling which could damage the engine.



**CAUTION**

Make sure no foreign matter enters the crankcase

# MAINTENANCE

## Air Filter

A dirty air filter will reduce the life span of the engine, make it difficult to start the engine, and reduce the unit's performance. Replace with new filter annually.

- To clean, remove the screws then remove outer casing.
- Remove the screws then remove air filter cover.
- Remove the foam element.
- Wash the foam element in solvent and let dry.
- Pour a small amount of oil on the foam element then squeeze out, but do not wring out, excess oil. Foam element should be damp, but not dripping.
- Reinsert the foam element into the air filter case.

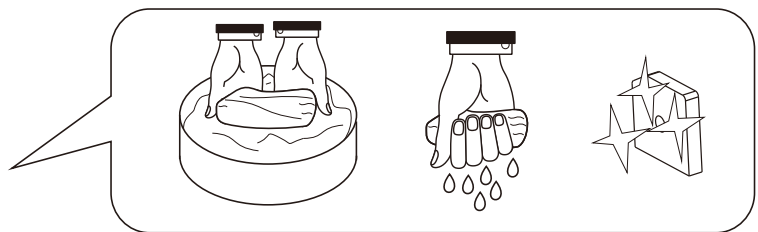
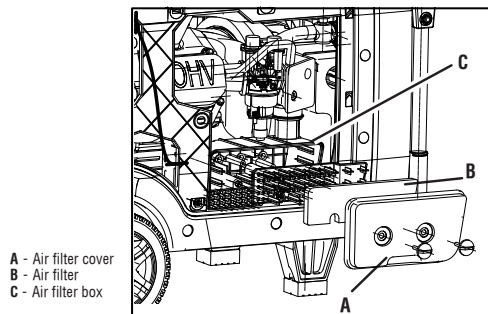

**Do not run the generator without reinstalling the foam element or excessive piston and cylinder wear may result.**

## Checking Muffler and Spark Arrester

- Inspect muffler for cracks, corrosion, or other damage.
- Loosen bolt, then remove muffler cap, muffler screen, and spark arrester.
- Check the muffler screen and spark arrester for carbon deposits. Remove carbon deposits with a wire brush.
- Check the muffler screen and spark arrester for damage. If damaged replace with Our replacement parts specifically designed for this unit.
- Install the spark arrester. Align the spark arrester projection with the hole in the muffler pipe.
- Install the muffler screen and muffler cap.

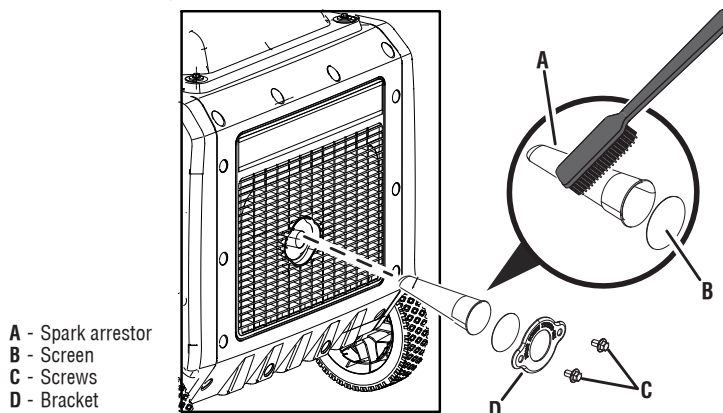

**Avoid contacting hot areas of this unit.**

- Use caution around the muffler, cylinder, and other engine parts as they can be extremely hot.
- Allow hot components to cool before touching.



# MAINTENANCE

## Fuel Tank Filter

- To clean, remove fuel cap and filter.
- Clean filter with gasoline.
- Wipe the filter with a clean rag.
- Install filter.
- Install fuel cap.

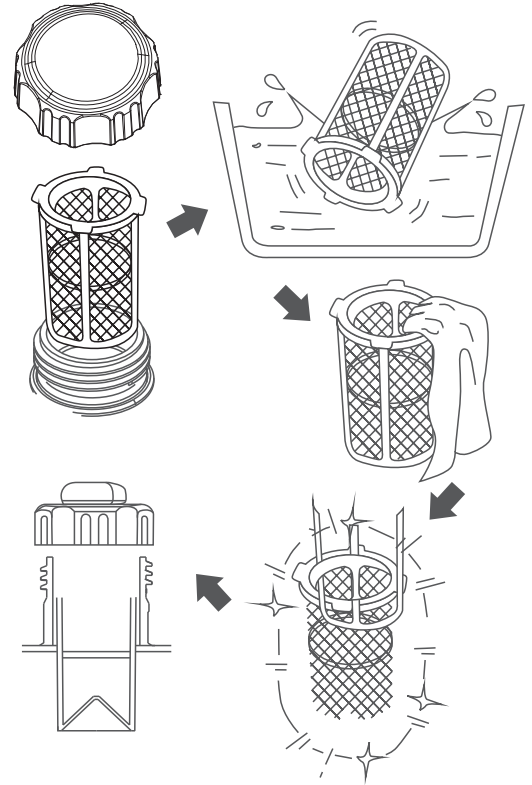

## Fuel Filter

- To clean, remove screws, remove outer casing, and drain fuel.
- Lift and hold onto the clamp, then remove hose from tank.
- Take out fuel filter.
- Clean filter with gasoline.
- Wipe the filter with a clean rag and return filter to tank.
- Install hose and clamp.
- Open fuel valve. Inspect for leakage.
- Install outer casing and tighten screws.

## Storage

To protect your generator from deterioration during long term storage, take the following preventative measures:

### EXTERIOR

- Remove any debris that has collected on the generator and around the muffler and controls. Use a vacuum cleaner to pick up loose debris. If dirt is caked on, use a soft bristle brush.
- Inspect air cooling slots. Remove any debris if obstructed.
- Store indoors and use a protective cover to protect from dust.

### FUEL

- For short-term storage, add fuel stabilizer to prevent stale fuel from causing acid and gum deposits in the fuel system and carburetor.
- For long-term storage, drain the fuel.

### ENGINE

- Remove spark plug. Pour about 1 TBL of SAE 10W-30 engine oil into the spark plug hole, then reinstall spark plug.
- With the 3 in 1 switch in the "OFF" position, pull the recoil starter several times to coat cylinder walls with oil.
- Slowly pull the recoil starter until you feel the engine build compression (when you feel resistance). Leave the engine in this state. This will help prevent rust build up in the cylinder walls.

# MAINTENANCE

## How to drain fuel

- Turn the switch to the “OFF” position.
- Remove fuel cap and fuel tank filter.
- Use a siphon to transfer gasoline from generator into a gasoline approved container.
- Wipe up any spilled fuel with a clean rag.
- Start generator engine and let it run until it stops and all remaining fuel is consumed. Do not connect electronic devices to generator during this process.
- Remove outer casing screws, then remove outer casing.
- Drain fuel from carburetor by loosening the drain screw on the carburetor float chamber.
- Turn the switch to “OFF”
- Tighten the drain screw.
- Install the outer casing and tighten screws.
- When the engine has completely cooled down, turn the Fuel Cap Air Vent to the “OFF” position.

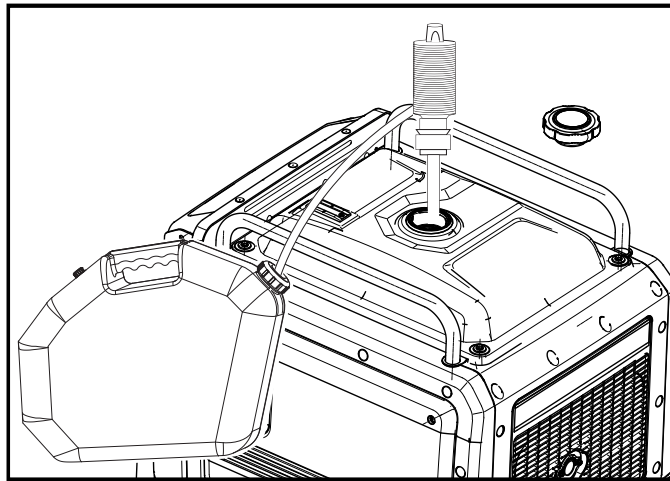
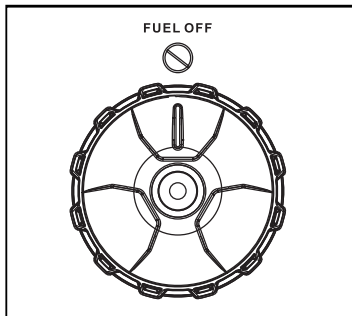

# TROUBLESHOOTING

<b>Problem</b>	<b>Cause</b>	<b>Solution</b>
Generator is running, but does not supply power.	<ol style="list-style-type: none"> <li>1. DC Circuit Breaker is "OFF"</li> <li>2. Green AC Pilot Light Indicator is off.</li> <li>3. Poor connection</li> <li>4. Defective cord set</li> <li>5. Connected device is faulty</li> <li>6. Fault in generator</li> </ol>	<ol style="list-style-type: none"> <li>1. Turn DC Circuit Breaker "ON"</li> <li>2. Stop engine and restart.</li> <li>3. Check and repair</li> <li>4. Check and repair</li> <li>5. Connect a device that is working properly</li> <li>6. Contact service department</li> </ol>
Engine runs good without load but bogs down when loads are connected	<ol style="list-style-type: none"> <li>1. Short circuit in connected device</li> <li>2. Generator is overloaded</li> <li>3. Clogged fuel filter</li> <li>4. Engine speed is too slow</li> <li>5. Short circuit in generator</li> </ol>	<ol style="list-style-type: none"> <li>1. Disconnect device</li> <li>2. See pg 20 "Don't overload generator"</li> <li>3. Clean or replace fuel filter</li> <li>4. Contact service department</li> <li>5. Contact service department</li> </ol>
Engine will not start, shuts down during operation, or starts and runs rough.	<ol style="list-style-type: none"> <li>1. switch set to "OFF"</li> <li>2. Dirty Air filter</li> <li>3. Clogged fuel filter</li> <li>4. Out of fuel or Stale fuel</li> <li>5. Spark plug wire disconnected from spark plug</li> <li>6. Bad spark plug</li> <li>7. Water in fuel</li> <li>8. Overchocking</li> <li>9. Low oil level</li> <li>10. Engine has flooded</li> <li>11. Faulty ignition</li> </ol>	<ol style="list-style-type: none"> <li>1. Turn switch to "CHOKE" then pull recoil starter.</li> <li>2. Clean or replace Air filter</li> <li>3. Clean or replace fuel filter</li> <li>4. Replace fuel</li> <li>5. Reconnect spark plug wire</li> <li>6. Clean or replace spark plug</li> <li>7. Drain fuel tank and replace fuel</li> <li>8. Turn off choke</li> <li>9. Add oil level.</li> <li>10. Wait 5 minutes and re crank engine</li> <li>11. Contact our dealer</li> </ol>
Engine lacks power	<ol style="list-style-type: none"> <li>1. Generator is overloaded</li> <li>2. Clogged fuel filter</li> <li>3. Dirty Air filter</li> <li>4. Engine needs servicing</li> </ol>	<ol style="list-style-type: none"> <li>1. See pg 20 "Don't overload generator"</li> <li>2. Clean or replace fuel filter</li> <li>3. Replace Air filter</li> <li>4. Contact service department</li> </ol>
Engine "hunts" or falters	<ol style="list-style-type: none"> <li>1. Choke was removed too soon</li> <li>2. Clogged fuel filter</li> <li>3. Carburetor is running too rich or too lean</li> </ol>	<ol style="list-style-type: none"> <li>1. Move to choke until engine runs evenly</li> <li>2. Clean or replace fuel filter</li> <li>3. Contact service department</li> </ol>

# DIAGRAM

