

# DUCAR

## Diagramme de pièces *Parts diagram*

À PARTIR DE SEPTEMBRE 2019 / FROM SEPTEMBER, 2019



Le modèle peut différer légèrement de la photo / *The model may differ slightly from the picture*

## **B1500E**

## **Déchiqueteuse à bois** *Wood chipper*

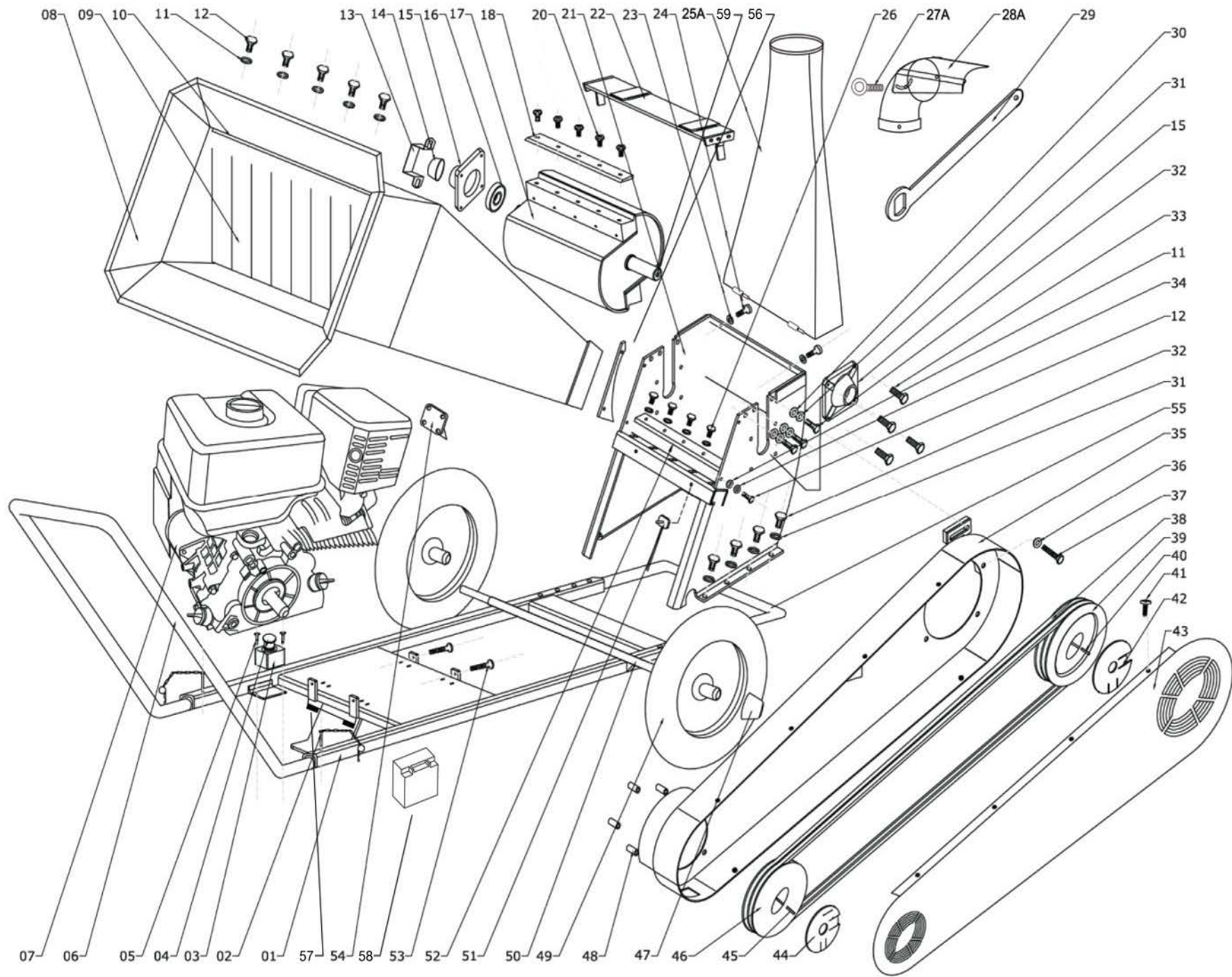

<b>NO</b>	<b>PART NUMBER</b>	<b>DESCRIPTION</b>	<b>QTY</b>
1	DUPB1500-1	FRAME	1
2	DUPB1500-2	PIN	2
3	DUPB1500-3	EMERGENCY SWITCH BOX	1
4	DUPB1500-4	EMERGENCY SWITCH	1
5	DUPB1500-5	BOLT	2
6	DUPB1500-6	HANDLE	1
7	DUPB1500-7	ENGINE	1
8	DUPB1500-8	HOPPER	1
9	DUPB1500-9	RUBBER COVER	1
10	DUPB1500-10	STRIP 3MM	1
11	DUPB1500-11	WASHER M6	6
12	DUPB1500-12	BOLT M6	6
13	DUPB1500-13	LOCK WASHER	1
14	DUPB1500-14	CAP BEARING	1
15	DUPB1500-15	BEARING HOUSING	2
16	DUPB1500-16	BEARING	2
17	DUPB1500-17	ROTOR	1
18	DUPB1500-18	BLADE	2
20	DUPB1500-20	SPECIAL BOLT FOR BLADE	5
21	DUPB1500-21	SHREDDER BOX	1
22	DUPB1500-22	TOP OF THE BOX	1
23	DUPB1500-23	WASHER	2
24	DUPB1500-24	BOLT M8X16	2
25A	DUPB1500-25	CONVEYOR - ROTATING CHUTE	1
26	DUPB1500-26	BOLT FOR COUNTER BLADE	5
27A	DUPB1500-27	DEFLECTOR BOLT - ROTATING CHUTE	1
28A	DUPB1500-28	ROTATING CHUTE	1
29	DUPB1500-29	ROTOR KEY	1
30	DUPB1500-30	LOCKING WASHER M8	6
31	DUPB1500-31	WASHER	14
32	DUPB1500-32	BOLT	14
33	DUPB1500-33	BOLT FOR BEARING HOUSING	8
34	DUPB1500-34	LOCKING WASHER MG	2
35	DUPB1500-35	BELT COVER	1
36	DUPB1500-36	WASHER	8
37	DUPB1500-37	BOLT	8
38	DUPB1500-38	V BELT	2
39	DUPB1500-39	BELT PULLEY	1
40	DUPB1500-40	KEY FOR ROTOR	1
41	DUPB1500-41	SCREW	4
42	DUPB1500-42	SAFETY RING FOR ROTOR	1

43	DUPB1500-43	BELT COVER - TOP	1
44	DUPB1500-44	SAFETY RING FOR ENGINE	1
45	DUPB1500-45	KEY	1
46	DUPB1500-46	BELT PULLEY	1
47	DUPB1500-47	CAP FOR WHEEL	1
48	DUPB1500-48	SPACER	4
49	DUPB1500-49	WHEEL	2
50	DUPB1500-50	AXLE	1
51	DUPB1500-51	SAFETY SWITCH	1
52	DUPB1500-52	COUNTER BLADE	1
53	DUPB1500-53	BOLT	2
54	DUPB1500-54	COVER OF THE MUFFLER	1
55	DUPB1500-55	BUMPER	1
56	DUPB1500-56	SUPPORT	1
57	DUPB1500-57	RUBBER FOOT	2
58	DUPB1500-58	BATTERY TTWPX7Z-BS	1
59	DUPB1500-59	LEFT HAND THREADED BOLT M10X36	1